



General Catalogue

**Antifriction Bearings**  
**Linear Systems**





# Contents

	Page
<b>Franke Principle</b>	4 – 5
<b>Company</b>	6 – 17
<b>Antifriction Bearings</b>	<b>18 – 63</b>
Antifriction Bearings at a Glance	18 – 21
Antifriction Bearings in Practice	22 – 25
Advantages and Characteristics	26 – 29
Bearing Elements, Slim Bearings	30 – 39
Bearing Assemblies	40 – 51
Rotary Tables	52 – 53
Accessories	54 – 55
Technical Information	56 – 63
<b>Linear Systems</b>	<b>64 – 119</b>
Linear Systems at a Glance	64 – 67
Linear Systems in Practice	68 – 71
Advantages and Characteristics	72 – 77
Franke Dynamic	78 – 91
Franke Power	92 – 93
Franke Robust	94 – 95
Linear Tables/Modules	96 – 105
Accessories	106 – 109
Technical Information	110 – 119
<b>Partners</b>	120 – 121
<b>Contact</b>	122 – 123

# The Franke Principle

The functionality of all Franke products is based on a 4-point contact. Rolling elements run on special race wires, which are enclosed in mating structures. The 4-point arrangement of these race wires enables loads to be borne from all directions. The Franke Principle facilitates individual design of the mating structure and a free choice of materials.

## Antifriction Bearings

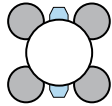

### Precise Rotations

Franke Antifriction Bearings bring the necessary movement to mechanical processes. They comprise four race rings, balls, a ball cage and – optionally – a mating structure.

The balls roll smoothly and with little friction on the four open race rings. The raceways are precisely adapted to the ball diameter using a special grinding process developed by Franke. This produces Antifriction Bearings that not only have particularly high precision and run behaviour, but are also suitable for the smallest mounting spaces.



The main attraction: rolling elements, which circulate smoothly on precisely calibrated race rings.

### The Range of Antifriction Bearings:

- Bearing elements that can be added directly to existing designs
- Slim bearings in accordance with international standards
- Ready-to-use bearing assemblies, also as aluminum light-weight bearings
- Motorized units with measuring systems and control

# Linear Systems

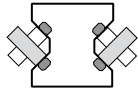

## Dynamic Movements

Franke Linear Systems are used wherever machines perform fast, straight movements – both horizontally and vertically. Aluminum guide rails with integrated steel or non-corrosive raceways form the basic components. Cassettes or pairs of roller shoes move on the rails with large rollers for particularly smooth and quiet running. Linear modules with belt, spindle or linear motor drive supplement the range.

The 4-point contact is connected to the **Guided Roller®** here, which moves on four raceways in the guide rail.

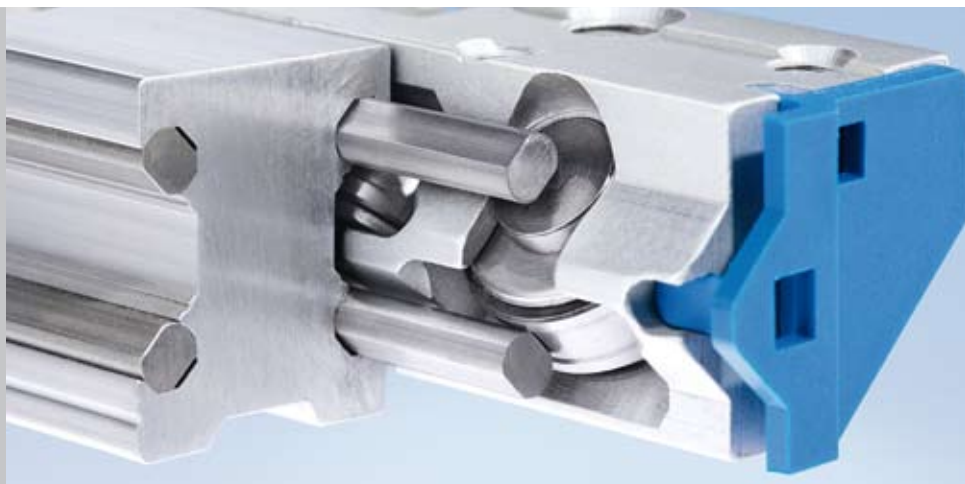

The **Guided Roller®** for perfect interaction: shaped roller profiles, which match the raceway precisely.

## The Range of Services:

- Systems with o-arranged rollers
- Systems with double-row recirculating rollers
- Systems with single-row recirculating balls
- Linear tables and linear modules

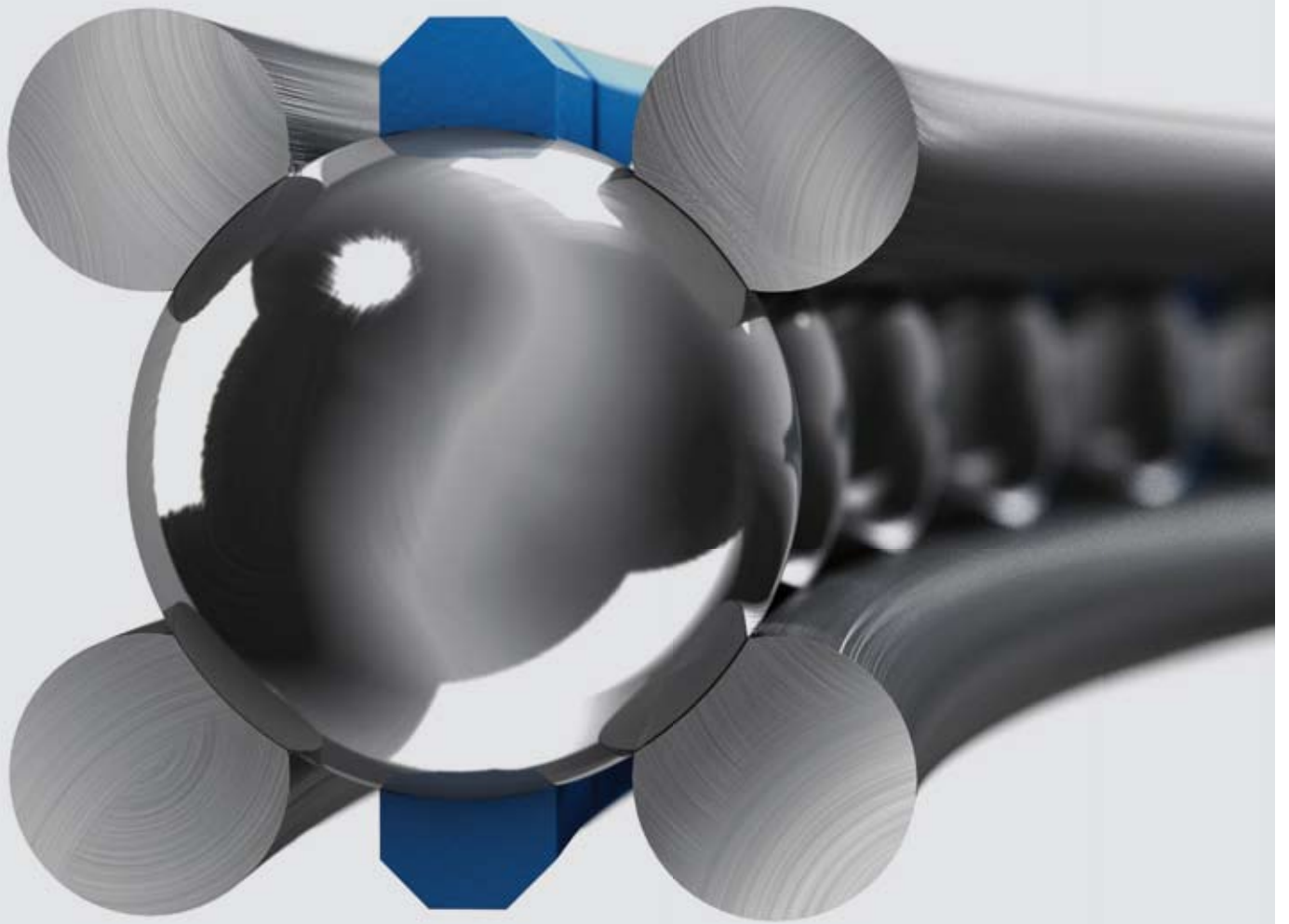

Erich Franke invented a new type of bearing in 1934 whilst searching for a particularly space-saving design: the Wire Race Bearing.

# Innovations are our speciality.

## One manufacturer. Many advantages.

The range of uses for Franke products is diverse. We develop customized customer solutions for different industries and focus very much on the individual application – from special products to standard parts.

### Individual Solutions

Our products are tailored to individual customer requirements. The 4-point contact is the prerequisite to this, because it allows the greatest degree of variability. The customer can choose freely with regard to material, geometry, size, hole pattern, gear or seals. Alternative materials, such as aluminum, non-corrosive, bronze, magnesium or plastic, can be used for the mating structure. We also produce individual components and complete systems – entirely to your specifications.

### With the Customer – For the Customer

Franke designs its products for each individual case in close cooperation with the customer. From the design to the construction of prototypes to extensive testing, we develop the most diverse solutions. This means we can produce individual units and series. Every product development is subject to extensive testing; customer training comes as standard.

### An Innovative Approach

Our flexibility with regard to customer requests is based on years of know-how and the enthusiasm continually to redevelop products or invent new ones. The more that is demanded of us, the better we become.

### Bearings for the Smallest Mounting Spaces

Franke Antifriction Bearings are suitable for every design, regardless of the environment. On request they can have a slimline design with two raceways housed on one race ring. The 4-point contact is also maintained here. The compact bearings can even be installed in the smallest mounting spaces, whilst retaining high rigidity and robustness.

### Stable Lightness of the Components

Franke believes in light-weight construction and so prefers to use aluminum. The advantages are obvious: the customer gets components that are around 65 percent lighter than comparable steel designs and that remain stable and load-bearing. Another plus: light-weight designs need less drive energy, the customer saves operating costs and helps the environment at the same time.

## As flexible as our customers. Yesterday. Today. Tomorrow.

Building on the effectiveness of the Wire Race Bearing, Franke develops customer-specific Antifriction Bearings and Linear Systems, which are precisely tailored to customer requirements.



From the design drawing to the finished product: Franke customers get everything from one place – individually customized to their needs.





Flexibility is everything. It defines our daily work, feeds into each individual product. We only make products individually to the customer's specifications. We employ more than 200 people at our headquarters in Aalen in Baden-Württemberg – in development and design, production and administration. Our managers guide the fortunes of the company from here. We have a global presence with numerous representations around the world.





Franke produces customized Antifriction Bearings and Linear Systems thanks to a combination of know-how, modern production facilities and committed employees.



Our staff devote themselves daily to the challenges that our customers bring to us. We adapt our products to the individual application in close partnership with the customer. Individuality is also apparent in production. From the multi-functional processing centre to the special machinery developed in house, we use diverse technologies. The wires for the raceways of Antifriction Bearings and Linear Systems are ground in a very special way – unique to Franke.

Quality tests, service life tests, specific customer tests and 100-% controls ensure the accuracy of our products. Franke's entire quality management is certified in accordance with DIN EN ISO 9001. Sustainability is apparent across our entire value chain. Our environmental management system meets the requirements of DIN ISO 14001.



## Diverse in application. Constant in advantages.

Our customer base is as broad as our range of products. For example, our customers are involved in machinery, medical technology and the textile industries. We have a leading position in the market with our Antifriction Bearings, particularly in computer tomography in medical technology and for circular knitting machines in the textile industry.



Medical technology  
Machinery  
Textile industry  
Clean room technology  
Solar industry  
Robotics  
Research  
Food industry  
Packaging industry

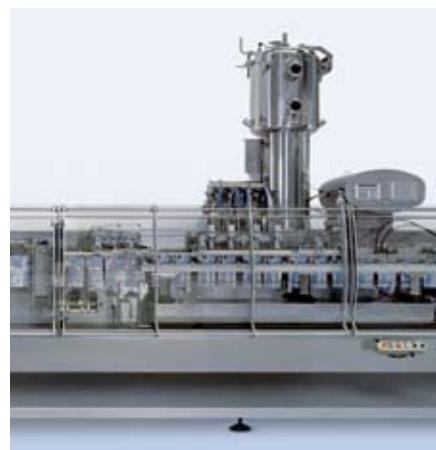



Our customers' trust in us and our products proven: our Antifriction Bearings and Linear Systems impress through their performance – regardless of the machine or industry they are used in. And this too applies across all applications and industries: the profitability of production plants and machine performance are improved in the long run with Franke technology.

Our concept for success: the load capacity and effectiveness of our Antifriction Bearings are largely independent of the enclosing material. The design and choice of material for the enclosing parts can be varied freely. The modular design of our Linear Systems is a further guarantee of the broad flexibility of our products.

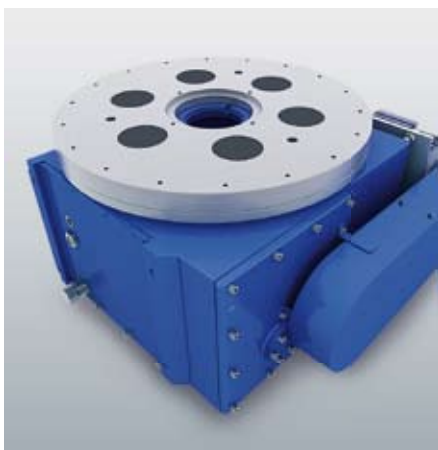

## Antifriction Bearings from Franke. All extras included.

Special requests are our business: we are experts in special bearings and satisfy unusual wishes when it comes to Antifriction Bearings. We offer a broad range of options for this purpose. Parameters such as load rating, stiffness, preload and adjustment are just as variable as height, width and bore shape or the different materials.



There are broad design possibilities for designers who use Franke Antifriction Bearings: the choice of design and material for the surrounding component is flexible. Steel, aluminium, non-corrosive, plastic or brass – our customers have free choice. This applies equally to the rolling elements, cages and race rings. There are different materials available for these too. The adjust-



Working in close co-operation with our customers, we engineer our products for the respective application. From conception to the construction of prototypes and extensive testing, we develop customised solutions, which we produce on special-purpose machines, some of which we have developed.

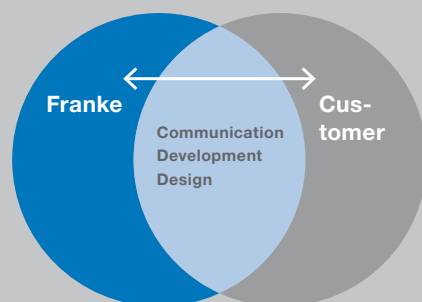

### We offer you:

- Advice on site
- Analysis of the current situation
- Development of alternatives
- Use optimization
- Component production
- Technical workshops

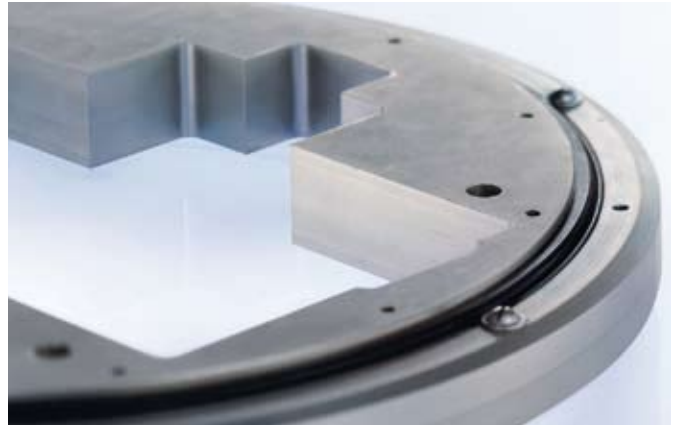

ability of the bearings does not stop there: we have different gears, seals, diameters, ball profiles etc. for our customers.

It is not just the selection range that is unique, but also the way the bearings are made: in contrast to conventional bearings, the rolling process does not occur directly between the rolling

elements and enclosed design, but rather smoothly on four open race rings. The raceways are matched to the ball diameter using a special grinding process. This special design principle produces an extremely compact bearing, which also suits very small spaces. Another plus: the low friction and high load capacity of our Antifriction Bearings reduce energy consumption.

Lubricant-free



Anodized aluminium



Special gear



# Linear Systems from Franke. A class of their own.

The company offering the most diverse range of Aluminium Linear Systems on the market is without question a specialist. The modular design of our Linear Systems enables us to fulfil diverse customer wishes. Different raceway profiles and roller shoes, special cassettes and variable guide widths also make an important contribution.

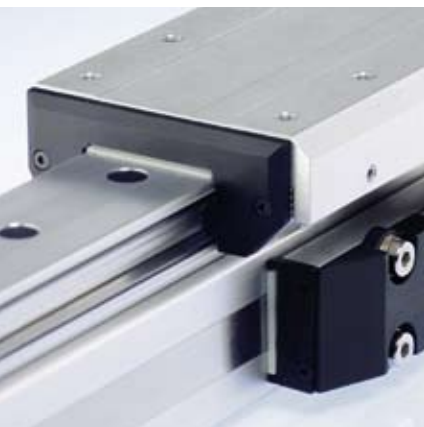

Whether it is systems with O-arranged raceways, double row recirculating rollers, single row recirculating balls or Linear Tables and Linear Modules – all guide bodies are high-strength aluminium. As a result, we can realise guide designs that are 65 % lighter than steel guides. The Aluminium Roller Guide is available as a double rail with cassette and a pair of single rails with roller shoes.

No lubricant residue



Aluminium profiles



Variable guide widths







The variety is supplemented by different lubricant variations: for example, we can make lubricant-free designs just as easily as systems with lifetime lubrication. Special production methods facilitate the combination of ground precision raceways of spring, non-corrosive or non-magnetic steel with almost every aluminium profile.

The secret of success for Linear Systems also lies in the specially processed raceways, which are integrated into the guide rails. The precision raceways are the basis for precise and silent running. The rollers designed for high load ratings are set in the roller shoes at a 90-degree angle and rest on a 4-point contact. This means that even high loads can be borne from all directions.

**Integrated wipers**



**Numerous variations**



**Adjustable slide resistance**





# Antifriction Bearings

	Page	
<b>Overview, Examples of Use, Advantages/Characteristics</b>	20 – 29	
<b>Bearing Elements</b>		
Type LEL	Ground design	30 – 33
Type LED	Double profile	34 – 35
Type LER	Rectangular profile	36
Type LEG	2-ring bearing element	37
Type LDD	Slim bearing	38 – 39
<b>Bearing Assemblies</b>		
Type LDL	Steel design	40 – 41
Type LDL	Aluminium design	42 – 43
Type LDL	Spur gear	44 – 47
Type LDL	Toothed belt gear	48 – 49
Type LDV	Steel design preference series	50
Type LDH	Steel design angular ball bearings	51
<b>Rotary Tables</b>		
Type LTA	Standard	52
Type LTB	Precise design	53
<b>Accessories</b>		
Antifriction Bearings	54 – 55	
<b>Technical Information</b>		
Bearing Elements	56 – 58	
Bearing Assemblies	58 – 60	
Rotary Tables	60	
Adjustment Values and Accuracy	61 – 62	

Bearing Elements

Bearing Assemblies

Rotary Tables

Accessories

Technical Information

# Antifriction Bearings at a Glance

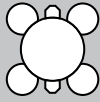
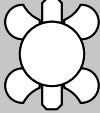
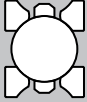
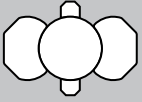
	Bearing Elements			
Type	LEL	LED	LER	LEG
				
<b>Components</b>	<ul style="list-style-type: none"> <li>• Round profile with ground raceway</li> <li>• Plastic cage with retained balls</li> </ul>	<ul style="list-style-type: none"> <li>• Double profile with ground or profiled raceway</li> <li>• Plastic cage with retained balls</li> </ul>	<ul style="list-style-type: none"> <li>• Rectangular profile with profiled raceway</li> <li>• Plastic cage with retained balls</li> </ul>	<ul style="list-style-type: none"> <li>• 2-ring bearing element with profiled raceway</li> <li>• Plastic cage with retained balls</li> </ul>
<b>Options</b>	<ul style="list-style-type: none"> <li>• Special materials</li> <li>• Special rolling elements</li> <li>• Surface coatings</li> <li>• Special cages</li> </ul>	<ul style="list-style-type: none"> <li>• Surface coatings</li> </ul>	<ul style="list-style-type: none"> <li>• Surface coatings</li> <li>• Special cages</li> </ul>	
<b>Advantages</b>	<ul style="list-style-type: none"> <li>• High precision and smooth running</li> <li>• High load rating</li> <li>• Load rating and cross section can be adjusted individually</li> </ul>	<ul style="list-style-type: none"> <li>• Higher load capacity and smooth running thanks to ground raceway</li> <li>• Short delivery times</li> <li>• Reasonable alternative to type LEL</li> </ul>	<ul style="list-style-type: none"> <li>• Short delivery times</li> <li>• Very cost-effective thanks to competitive price, easy fitting and simplified finishing of the bearing bed</li> <li>• High stiffness</li> <li>• High load rating</li> </ul>	<ul style="list-style-type: none"> <li>• Smallest mounting space, as particularly compact</li> <li>• Easy fitting</li> <li>• Consists of just two race rings</li> </ul>
<b>Use</b>	<ul style="list-style-type: none"> <li>• Individually adjustable to the application, therefore, suitable for almost all uses</li> </ul>	<ul style="list-style-type: none"> <li>• Standard line if series needed</li> </ul>	<ul style="list-style-type: none"> <li>• Maximum stiffness for diverse applications</li> </ul>	<ul style="list-style-type: none"> <li>• Replaces conventional deep groove ball bearings</li> <li>• Ideal for radial loads</li> </ul>
<b>Race ring diameter (mm)</b> Standard Special	1.5 – 7 0.75 – 22	4	4 x 3	5
<b>Ball diameter (mm)</b> Standard Special	5 – 16 4 – 50	9.525 10, 12	9.525	5
<b>Bearing cross section (mm)</b> Standard Special	5.9 x 5.9 – 20.9 x 20.9 Customer's choice	12.86 x 12.86 – 12.95 x 12.95 13.19 x 13.19 – 14.61 x 14.61	11 x 13	10.51 x 5
<b>Ball pitch diameter (mm)</b> Standard Special	70 – 2000 40 – 7000	100 – 1500	100 – 1500	100 – 500
<b>More on page</b>	30 – 33	34 – 35	36	37

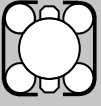
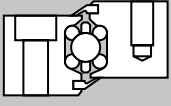
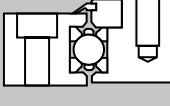
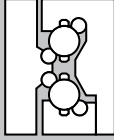
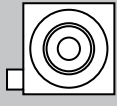
		Bearing Assemblies			Systems
	<b>LDD</b>	<b>LDL</b>	<b>LDV</b> 	<b>LDH</b>	<b>LTA, LTB</b>
					
	<ul style="list-style-type: none"> <li>• Slim bearing with ground raceway</li> <li>• Encapsulating steel housing</li> </ul>	<ul style="list-style-type: none"> <li>• Bearing assembly of steel or aluminium</li> <li>• Double-sided seal</li> <li>• With or without gear</li> </ul>	<ul style="list-style-type: none"> <li>• Bearing assembly of steel</li> <li>• One-sided seal</li> <li>• NEW with outer gear</li> </ul>	<ul style="list-style-type: none"> <li>• Bearing assembly of steel as angular ball bearing</li> </ul>	<ul style="list-style-type: none"> <li>• Rotary Tables and positioning systems</li> <li>• Rotary Tables with gear and drive unit</li> </ul>
		<ul style="list-style-type: none"> <li>• Special materials</li> <li>• Special rolling elements</li> <li>• Surface coatings</li> <li>• Gear to specifications</li> </ul>		<ul style="list-style-type: none"> <li>• Inner to outer ring electrically insulated</li> </ul>	<ul style="list-style-type: none"> <li>• End switch</li> <li>• Rotary encoder</li> <li>• Motorisation</li> <li>• Steering</li> <li>• Measuring systems</li> </ul>
	<ul style="list-style-type: none"> <li>• Easy fitting, as pre-finished bearing element</li> <li>• Bearing cross section in accordance with international standards</li> </ul>	<ul style="list-style-type: none"> <li>• Ready-to-connect complete bearing</li> <li>• With preload</li> <li>• High accuracy</li> </ul>	<ul style="list-style-type: none"> <li>• Ready-to-connect complete bearing</li> <li>• Available from stock</li> <li>• Competitive price</li> </ul>	<ul style="list-style-type: none"> <li>• High accuracy</li> <li>• Geometry, cross section, set-up of choice</li> <li>• Adjustment adjustable</li> <li>• Silent bearing for very quiet and low-vibration running</li> </ul>	<ul style="list-style-type: none"> <li>• Franke four-point bearing as basic component</li> <li>• Adaptors for customer-specific motors</li> <li>• Aluminium housing</li> <li>• High accuracy</li> <li>• High centre freedom</li> </ul>
	<ul style="list-style-type: none"> <li>• Prefinished bearing element for diverse applications</li> </ul>	<ul style="list-style-type: none"> <li>• Individually adjustable to the application, therefore, suitable for almost all uses</li> </ul>	<ul style="list-style-type: none"> <li>• Individual adjustment to the application possible if series required</li> </ul>	<ul style="list-style-type: none"> <li>• For very dynamic applications</li> <li>• Individually adjustable to the application</li> </ul>	<ul style="list-style-type: none"> <li>• For diverse applications in industry and research</li> </ul>
	–	–	–	–	–
	6 – 20	–	–	–	–
	3/8" – 1"	–	–	–	–
	5.125" – 26"	100 – 1500 Customer's choice	200 – 600	21" – 41" Customer's choice	100 – 400 Customer's choice
	38 – 39	40 – 49	50	51	52 – 53

# Antifriction Bearings in Practice

After in-depth consultation and precise design and production, Franke Antifriction Bearings provide movement in diverse applications. For example, in computer tomography, processing centres, textile machinery, machinery for chip production, indexing tables or robots. Our Antifriction Bearings pass the practical test day after day – you can rely on that.

## In Medical Technology: Computer Tomography

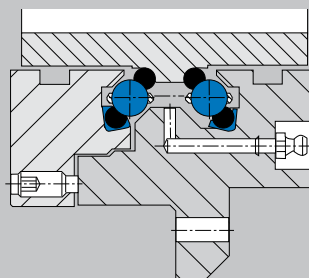

Photo credit: Siemens AG

The patented Franke **Fluesterlager**® as the main bearing in computer tomography contributes to exact x-rays thanks to its design tailor-made to the needs of medical technology.

### The Features:

- Smooth and low-vibration running is even ensured at high rotary speeds thanks to CNC-ground raceways.
- The elastomer profiles between the race rings and the race ring bed form the basis for muted noise development and electrical insulation of the inner and outer ring.
- The silent bearing impresses with rotary speeds of up to 300 revolutions per minute.



Bearing diameter: 1500 mm

## In Solar Industries: Tracking Systems



The best possible positioning to the sun is required for photovoltaic modules or solar panels to obtain an optimum yield in solar energy systems. Franke Antifriction Bearings in tracking systems automatically align solar collector systems such that radiation from the sun is collected in ideal fashion.

### The Features:

- The 4-point system of Franke Antifriction Bearings makes for optimum swivelling of solar collector systems along with a high degree of rigidity.
- Built directly into the surrounding structure, these bearings are extremely space-saving.
- Good value for money tops off the benefits of this Franke product.

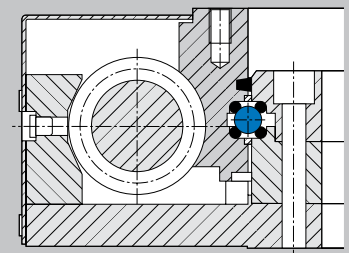

Bearing diameter: 170 mm

## In the Textile Industry: Circular Knitting Machines

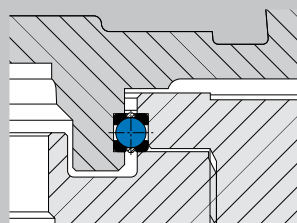

Photo credit: Mayer & Cie. GmbH & Co.KG

Our bearing elements for circular knitting machines have a decisive influence on the quality of the textiles due to their precision.

### The Features:

- Even under severe thermal and mechanical loads, the bearing elements enable exact radial and axial guiding of the needles.
- The rotary speeds are up to 60 revolutions per minute.
- The quality of the machines is determined amongst other things by the quiet running of the bearing and the high surface quality of the raceways.



Bearing diameter: 960 mm

## In Machinery: Machining Centres

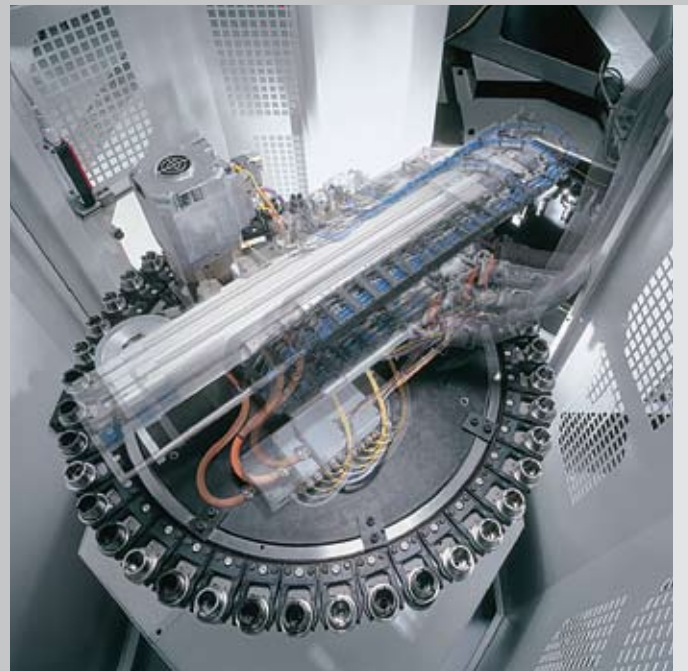
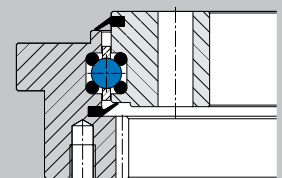

Photo credit: Hermler AG

In tool changers at machining centres, our bearing assemblies help to ensure that different tools are fed quickly and precisely into the machining head.

### The Features:

- Larger bore possibility of the bearing assemblies, the drive system can be installed to the inside.
- Labyrinth seals protect the raceways of the bearing assemblies from chipping and coolants.
- The preload of the bearing guarantees high accuracy and even adjustment – thus, nothing stands in the way of quiet running and maximum precision.



Bearing diameter: 970 mm

# Antifriction Bearings in Practice

## In Machinery: Indexing Tables

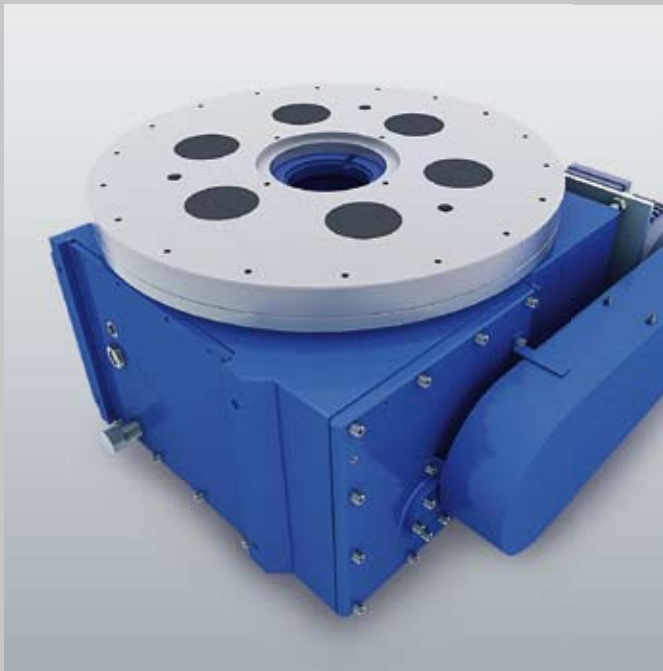

By using indexing tables, also called Rotary Tables, tools are moved precisely. The constant and precise movement of these indexing tables is based on our bearing elements amongst other things.

### The Features:

- The bearing elements are precisely adjusted to the different loads. Enormous loads can easily be borne from all directions.
- The Antifriction Bearings guarantee that the Rotary Table can move without jerks or shocks, high repeat accuracy is included.

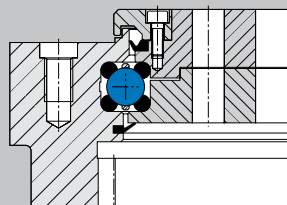

Bearing diameter: 800 mm

## In Automation: Robots



Our bearing elements are ideally suited for use in the mobile axes of small robots.

### The Features:

- The ingenious 4-point system from Franke facilitates high capacity from all directions of movement.
- As the bearing element is integrated into the existing robot design, only minimal installation space is needed.
- The larger bore possibility of the bearing enables cables and supply pipes to be fed through.

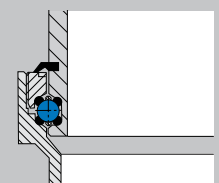

Bearing diameter: 240 mm



## In Clean Room Technology: Machinery for Chip Production

## In the Aviation Industry: Turbine Testing



Wafer steppers are used for microchip production in the clean room. The illumination optics form the heart of this machine. They produce the filigree chip structures. A component of the optics: a Franke Antifriction Bearing.

### The Features:

- So that the illumination optics can work with extremely low tolerances, the bearing has good radial and axial accuracy and high stiffness.
- Low-abrasion materials, special balls, a special ball cage and freedom from lubricants meet the necessary requirements for the clean room.
- The final cleaning and packing of the bearing is effected for clean room level 10000.
- Weight is saved by using aluminium.

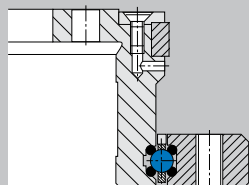

Bearing diameter: 138 mm



Franke Special Bearings of 700 to 1500 mm are used in testing stations for turbines. They are used to position the conducting segments and rotating blades. The bearings are integrated in precise housing contours to record the complex measuring and testing sensors.

### The Features:

- The bearings withstand temperatures up to 200 °C.
- High accuracy requirements for radial and axial running are fulfilled.
- The bearings can optionally be adjusted to all interface dimensions.

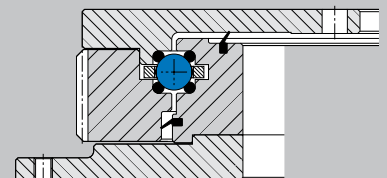

Bearing diameter: 850 mm

# Bearing Elements – Advantages and Characteristics

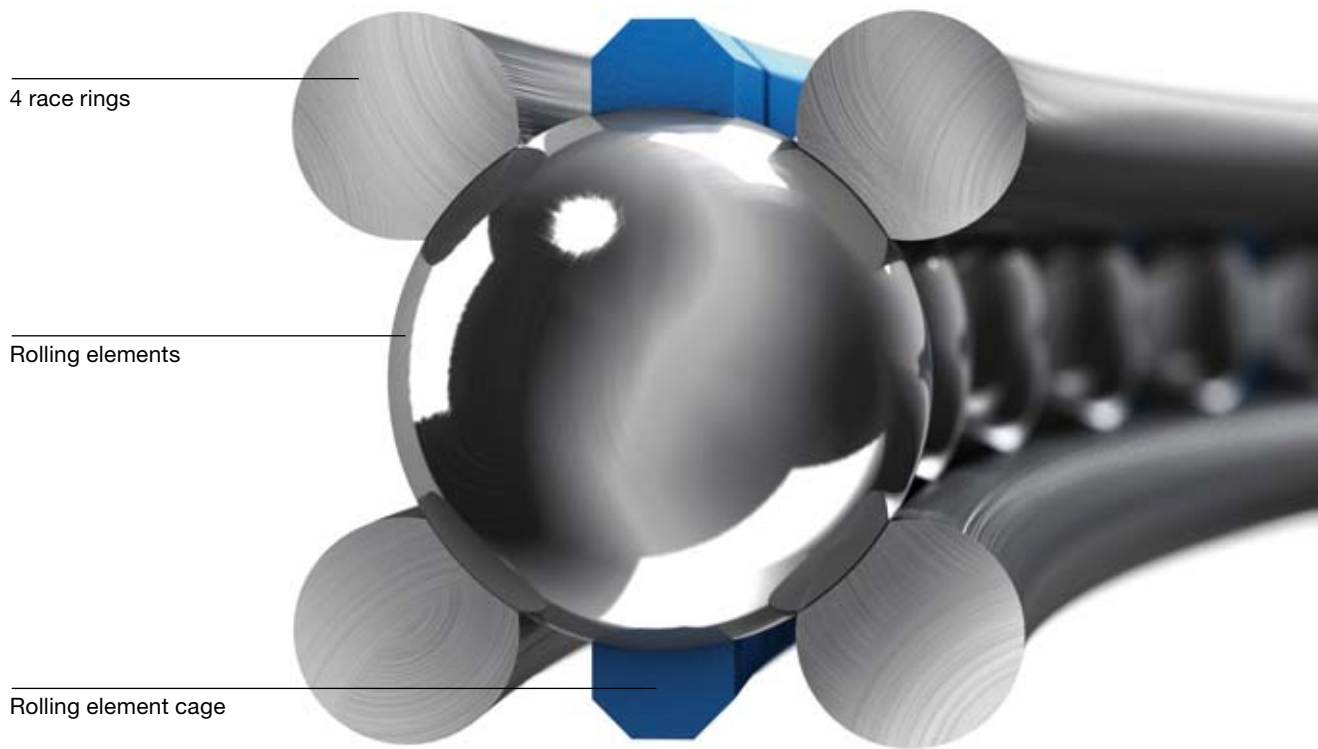

## The Characteristics:

### Race Rings

The four race rings have a diameter of 1.5 to 7 mm as standard. The special diameters are 0.75 to 22 mm. Different race ring diameters can be combined with different ball diameters.

The raceway of the ring is optimally adjusted to the diameter of the rolling element in its osculation. Osculation and angle support of the race ring are individually specified and are determined by the installation situation.

The raceway surface is either ground or drawn. Ground surfaces provide the highest precision and smoothest running. However, Franke also offers unground ball race rings.

There are several race ring profiles to choose from (see p. 30–39).

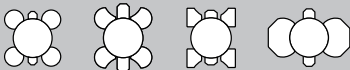

### Rolling Elements

The standard steel rolling elements correspond to DIN 5401, G28. They are matched in tolerance and grade. Grades up to G3 are available for high accuracy applications.

You can choose between rolling elements of non-corrosive, non-magnetic steel or ceramics for special cases.

For particularly high requirements with regard to load rating and stiffness, Franke prefinished bearing assemblies with rollers as cross roller bearings are suitable.



> **The Franke principle as a film:**  
[www.franke-gmbh.com](http://www.franke-gmbh.com)

## The Advantages:

- Direct integration of the bearing in the application
- Minimum space needed thanks to compact design and low bearing cross section
- Acceptance of loads from all directions thanks to four-point geometry
- Best radial and axial accuracy
- High running performance and capacity thanks to raceways precisely adjusted to the ball diameters
- Shock-resistant thanks to internal elasticity
- Rotational resistance freely adjustable



### Segmented Rolling Element Cage

The plastic cage holds the rolling elements in the predetermined position, facilitates fitting and reduces friction. The running is improved and less lubricant is needed.

Segmenting in equally long sections is oriented by the bearing diameter. It guarantees silent running. Sufficient clearance for thermal expansion is also guaranteed. The expansion depends, amongst other things, on the ball or ball pitch diameter.

For special cases, e.g. heavy soiling and temperatures above 120 °C, flat cages of brass or non-corrosive are available.



### Housing Design

The race rings provide the necessary stiffness and precision of the bearing as far as possible. They bear the main load. The possibilities are endless for designing the connecting design. The encapsulating design is not directly exposed to the demands of the rolling elements. Thus, steel, cast iron, aluminium, non-corrosive, bronze, compounds or plastic can be used for the design. The weight saving is up to 65 % depending on the material chosen.

The result: a component with high quality mounting, which matches a conventional steel bearing in running performance, capacity and precision and is precisely adjusted to the application.

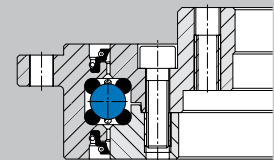

Seals

### Seal

Seals can be ordered as bulk stock for sealing the design. Viton seals are available for high temperatures or aggressive media.

# Bearing Assemblies – Advantages and Characteristics

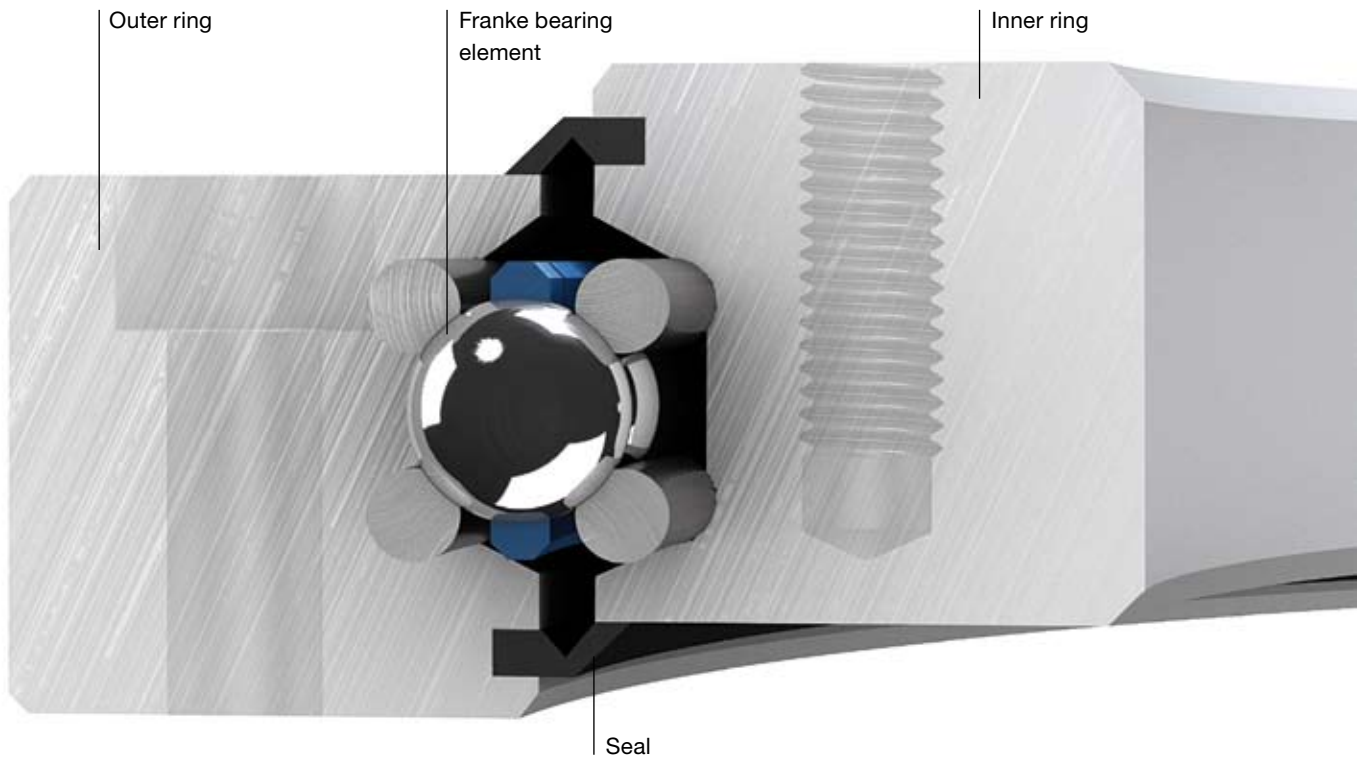

## The Characteristics:

### Bearing Element

The integrated bearing element comprises four race rings and a plastic cage with retained balls. Depending on the application of the bearing assembly, the bearing element is designed as a conventional four-point bearing, radial or axial bearing. For special applications, such as main bearings for computer tomographs, there are double row angular bearings of various designs.

The performance of the bearing assembly is decisively influenced by the bearing element used. The right bearing element is chosen according to the requirements of the bearing assembly. Depending on the application and the load situation, bearing elements of the type LEL with ground raceway or LED type or LER with profiled raceway are used. In addition to the standard ranges, various special combinations of race ring cross sections and rolling element diameters are possible, to meet the requirements of your individual application.

### Outer and Inner Ring (toothed on request)

The solid outer and inner rings enclose the bearing element. They are designed with ready-to-mount bore shape and a standard adjustment (see p. 61 – 62 for more details on setting the adjustment).

Outer and inner rings are available in three standard bore shapes:

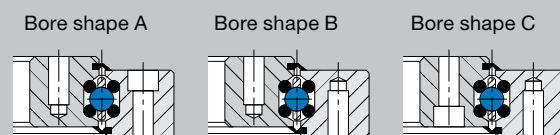

Other bore shapes on request.

Outer and inner ring can be equipped with gear on request. The standard gear corresponds to DIN 3967 in quality 8e25 basic profile DIN 867. All standard and special gears are, of course, part of the Franke range.



## The Advantages:

- Customer-specific special bearing
- Free choice of material, aluminium version 65 % lighter than steel design
- Individually adjusted bore shape for direct incorporation into the construction
- Integrated Franke bearing element for loads from all directions, high performance and precision
- High dynamic, maximum peripheral speed up to 20 m/s

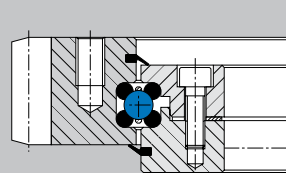

Adjustment shim

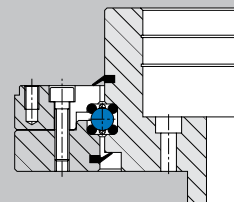

Solid adjustment

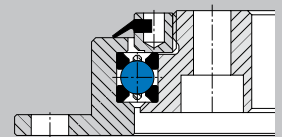

Ring nut

### Seal

A lip seal is a standard component of Franke bearing assemblies. Both sides are sealed on the LDL type. The LDV type has a one-sided seal.

We recommend viton seals for applications at high temperatures or for aggressive media.

Special bearing assemblies can be adjusted to requirements. All seal variations are available here.

### Adjustment

Franke bearing assemblies are preloaded and free from clearance. The rotational resistance can be adjusted to the customer's requirements on request.

Setting using washers is the most flexible method, as this still allows readjustment of the adjustment later on.

When setting using solid adjustment, the adjustment surface is brought to the correct level by subsequent grinding. The advantage of this method is the high accuracy.

Adjusting using a ring nut is the cost-effective alternative. A screw thread is inserted in the divided inner or outer ring for this method. An adjusting ring can be turned to the desired preload using the thread.

# Bearing Elements

## Type LEL

### Ground raceways

#### LEL 1.5/5

Ø KK mm	Load ratings KN				Weight kg	Order no.
	Coa	Cor	Ca	Cr		
70	13	6	7	6	0.04	68470A
80	15	7	7	6	0.05	68472A
90	18	8	8	7	0.05	68474A
100	20	9	8	7	0.06	68476A
110	22	10	8	7	0.07	68478A
120	23	11	9	8	0.07	68480A
130	25	12	9	8	0.08	68482A
140	27	13	9	8	0.09	68484A
150	30	14	10	8	0.09	71033A

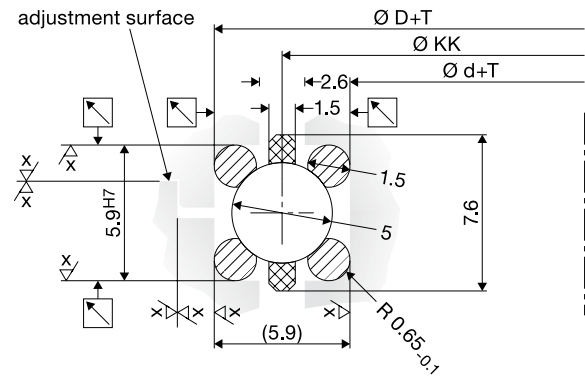

#### LEL 2.5/8

Ø KK mm	Load ratings KN				Weight kg	Order no.
	Coa	Cor	Ca	Cr		
160	73	35	20	17	0.10	71037A
170	79	37	20	17	0.11	71041A
180	83	39	20	18	0.11	71045A
190	88	41	21	18	0.12	71049A
200	92	43	21	18	0.12	71053A
210	97	46	22	19	0.13	71057A
220	102	48	22	19	0.13	71061A
230	106	50	22	19	0.14	68487A
240	112	53	23	20	0.15	68489A
250	115	54	23	20	0.15	68491A
260	121	57	24	20	0.16	68493A
270	126	59	24	21	0.16	68495A
280	130	61	24	21	0.17	68497A
290	135	64	25	21	0.18	68499A
300	139	65	25	21	0.18	68501A

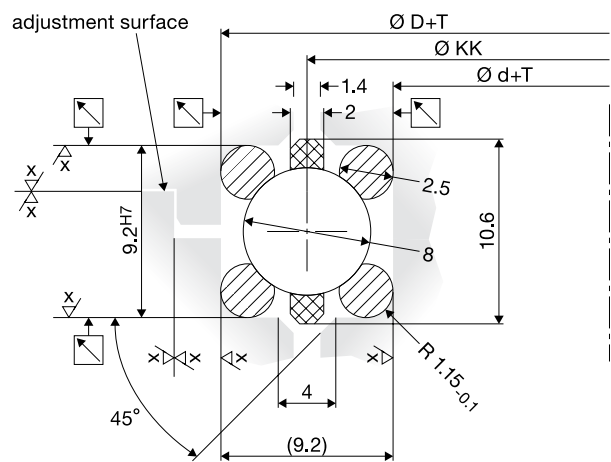

Materials

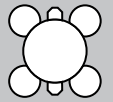

	Race ring	Balls	Cage
<b>Standard</b>	54SiCr6	100Cr6 DIN 5401, G28	PA12
<b>Special</b>	Niro X12CrNi177 Niro X7CrNiAl177 Duratherm	Niro X45Cr13 POM Ceramic Al <sub>2</sub> O <sub>3</sub> Ceramic Si <sub>3</sub> N <sub>4</sub>	Non-corrosive Bronze Brass Teflon Laminate

LEL 4/9.525

Ø KK mm	Load ratings KN				Weight kg	Order no.
	Coa	Cor	Ca	Cr		
200	118	55	26	23	0.39	68502A
210	123	58	27	23	0.41	68504A
220	128	60	27	23	0.43	68506A
230	136	64	28	24	0.45	68508A
240	142	67	28	24	0.47	68510A
250	147	69	28	25	0.49	68512A
260	153	72	29	25	0.51	68514A
270	161	76	29	25	0.53	68516A
280	166	78	30	26	0.55	68518A
290	172	81	30	26	0.57	68520A
300	177	83	30	26	0.59	67503A
320	191	90	31	27	0.63	67505A
340	202	95	32	28	0.66	67507A
360	215	101	33	28	0.71	67509A
380	226	106	33	29	0.74	67511A
400	240	113	34	29	0.78	68522A
420	251	118	35	30	0.82	68524A
440	264	124	35	31	0.86	68526A
460	275	129	36	31	0.90	68528A
480	286	135	36	31	0.94	68530A
500	299	141	37	32	0.98	68532A
520	310	146	37	32	1.02	68534A
540	302	142	38	33	1.06	68536A
560	312	147	38	33	1.10	68538A
580	325	153	39	34	1.14	68540A
600	335	158	39	34	1.17	68542A
620	348	164	40	35	1.22	68544A
640	358	168	40	35	1.25	68546A
660	370	174	41	35	1.29	68548A
680	381	179	41	36	1.33	68550A
700	393	185	42	36	1.37	68552A
720	403	190	42	37	1.41	68554A
740	414	195	43	37	1.45	68556A
760	426	201	43	37	1.49	68558A
780	436	205	43	38	1.53	68560A
800	449	211	44	38	1.57	68562A
820	459	216	44	38	1.61	68564A
840	472	222	45	39	1.65	68566A
860	482	227	45	39	1.68	68568A
880	495	233	45	39	1.73	68570A
900	505	238	46	40	1.76	68572A
920	517	243	46	40	1.80	68573A
960	540	254	47	41	1.88	68575A
1000	560	264	48	41	1.96	68577A
1100	619	291	49	43	2.16	68582A
1200	674	317	51	44	2.35	68587A
1300	730	344	52	45	2.55	68592A
1400	788	371	54	47	2.75	68597A
1500	844	397	55	48	2.94	68602A

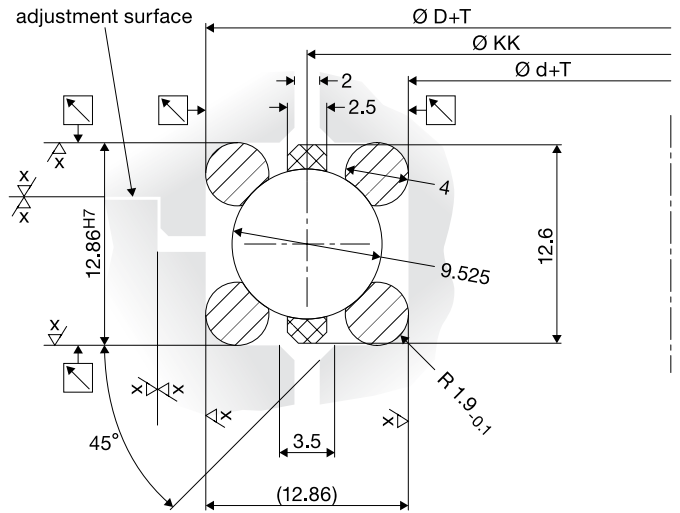

Ø KK ≤ 500 mm T = IT6    Ø KK > 500 mm T = IT7     $\frac{X}{Y} = Ra 3.2$   
Other diameters and in-between sizes available on request.

# Bearing Elements

## Type LEL

### Ground raceways

#### LEL 5/12

Ø KK mm	Load ratings KN				Weight kg	Order no.
	Coa	Cor	Ca	Cr		
220	221	104	37	32	0.65	68603A
230	231	109	38	33	0.68	68605A
240	242	114	38	33	0.71	68607A
250	253	119	39	34	0.74	68609A
260	263	124	39	34	0.77	68611A
270	274	129	40	35	0.80	68613A
280	285	134	41	35	0.83	68615A
290	295	139	41	36	0.86	68617A
300	306	144	42	36	0.89	68619A
320	328	154	43	37	0.95	68621A
340	349	164	44	38	1.01	68623A
360	370	174	45	39	1.07	68625A
380	392	184	46	40	1.13	68627A
400	408	192	46	40	1.18	68629A
420	429	202	47	41	1.24	68631A
440	450	212	48	42	1.30	68633A
460	472	222	49	42	1.36	68635A
480	493	232	50	43	1.42	68637A
500	515	242	51	44	1.48	68639A
520	536	252	52	45	1.54	68641A
540	557	262	52	45	1.60	68643A
560	579	272	53	46	1.66	68645A
580	600	282	54	46	1.73	68647A
600	622	293	54	47	1.79	68649A
620	638	300	55	47	1.84	68651A
640	659	310	55	48	1.90	68653A
660	680	320	56	49	1.96	68655A
680	702	330	57	49	2.02	68657A
700	723	340	58	50	2.08	68659A
720	745	350	58	50	2.14	68661A
740	766	361	59	51	2.20	68663A
760	787	371	59	51	2.26	68665A
780	809	381	60	52	2.32	68667A
800	830	391	61	52	2.38	68669A
820	852	401	61	53	2.44	68671A
840	868	408	61	53	2.49	68673A
860	889	418	62	54	2.55	68675A
880	911	429	62	54	2.61	68677A
900	932	439	63	55	2.67	68679A
920	953	449	64	55	2.73	68680A
940	975	459	64	55	2.79	68681A
960	996	469	65	56	2.86	68682A
980	1018	479	65	56	2.92	68683A
1000	1034	486	65	57	2.97	68684A
1100	1141	537	68	59	3.27	68689A
1200	1242	585	70	61	3.56	68694A
1300	1349	635	72	62	3.86	68699A
1400	1456	685	74	64	4.17	68704A
1500	1558	733	76	66	4.46	68709A

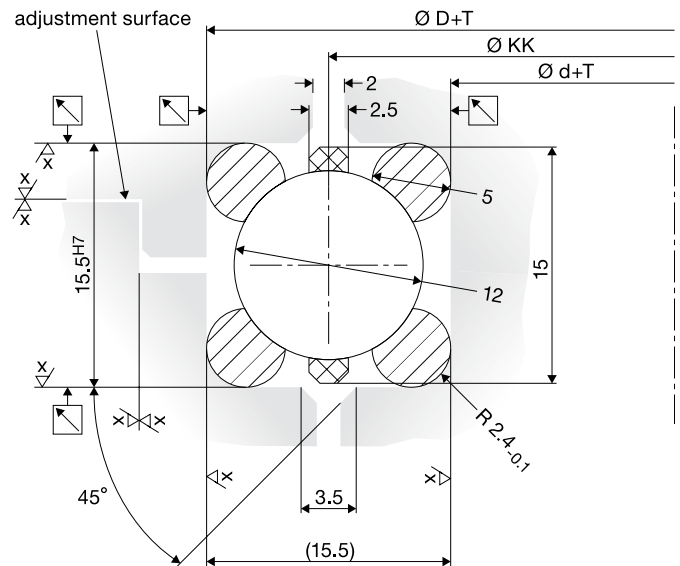



Materials

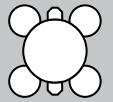

	Race ring	Balls	Cage
<b>Standard</b>	54SiCr6	100Cr6 DIN 5401, G28	PA12
<b>Special</b>	Niro X12CrNi177 Niro X7CrNiAl177 Duratherm	Niro X45Cr13 POM Ceramic Al <sub>2</sub> O <sub>3</sub> Ceramic Si <sub>3</sub> N <sub>4</sub>	Non-corrosive Bronze Brass Teflon Laminate

LEL 7/16

Ø KK mm	Load ratings KN				Weight kg	Order no.
	Coa	Cor	Ca	Cr		
340	432	203	61	53	1.89	68711A
360	466	219	63	54	2.02	68713A
380	491	231	64	55	2.13	68715A
400	517	243	65	56	2.24	68717A
420	542	255	66	57	2.35	68719A
440	567	267	67	58	2.46	68721A
460	593	279	69	59	2.57	68723A
480	618	291	70	60	2.68	68725A
500	644	303	71	61	2.79	68727A
520	678	319	72	62	2.92	68729A
540	703	331	73	63	3.03	68731A
560	728	343	74	64	3.14	68733A
580	753	355	78	68	3.25	68735A
600	779	366	76	66	3.36	68737A
620	804	378	77	66	3.47	68739A
640	829	390	78	67	3.58	68741A
660	855	402	78	68	3.69	68743A
680	889	418	80	69	3.82	68745A
700	914	430	81	70	3.93	68747A
720	939	442	81	70	4.04	68749A
740	965	454	82	71	4.15	68751A
760	990	466	83	72	4.26	68753A
780	1015	478	84	72	4.37	68755A
800	1041	490	84	73	4.48	68757A
820	1074	506	85	74	4.61	68759A
840	1100	518	86	75	4.72	68761A
860	1125	529	87	75	4.83	68763A
880	1151	541	88	76	4.94	68765A
900	1176	553	88	76	5.05	68767A
920	1201	565	89	77	5.16	68768A
940	1227	577	90	78	5.27	68769A
960	1252	589	90	78	5.38	68770A
980	1277	601	91	79	5.49	68771A
1000	1302	613	92	79	5.60	68772A
1060	1387	653	94	81	5.95	68775A
1100	1438	677	95	82	6.17	68777A
1160	1522	716	97	84	6.52	68780A
1200	1573	740	98	85	6.74	68782A
1260	1649	776	100	86	7.07	68785A
1300	1700	800	101	87	7.29	68787A
1360	1784	840	103	89	7.64	68790A
1400	1835	864	104	90	7.86	68792A
1460	1911	899	106	91	8.19	68795A
1500	1970	927	107	92	8.43	68797A
1600	2021	951	108	93	8.65	68799A
1700	2122	999	110	95	9.09	68801A
1800	2232	1050	112	97	9.55	68803A
1900	2283	1074	113	97	9.77	68805A
2000	2629	1237	119	103	11.24	68807A

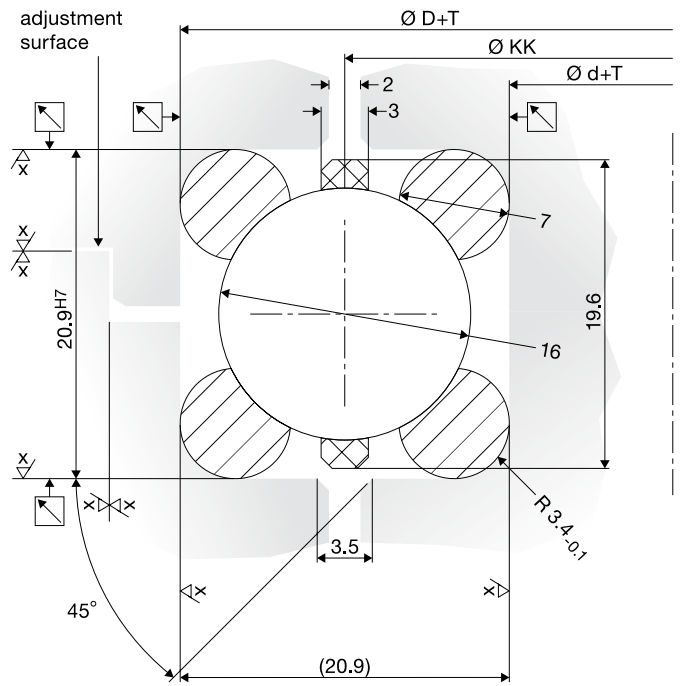

Ø KK ≤ 500 mm T = IT6    Ø KK > 500 mm T = IT7     $\frac{X}{Y} = Ra 3.2$   
Other diameters and in-between sizes available on request.

# Bearing Elements

## Type LED

Double profile,  
ground or unground raceways

### LED 4/9.525 ground

Ø KK mm	Load ratings KN				Weight kg	Order no.
	Coa	Cor	Ca	Cr		
100	53	25	20	17	0.26	68310A
120	64	30	21	18	0.28	68314A
140	77	36	23	20	0.31	68318A
160	87	41	23	20	0.34	77202A
180	100	47	25	22	0.37	77206A
200	111	52	27	23	0.40	77210A
220	123	58	28	24	0.43	77214A
240	134	63	28	24	0.47	77218A
260	147	69	29	25	0.51	77222A
280	155	73	30	26	0.56	77226A
300	168	79	31	27	0.61	77230A
320	179	84	31	27	0.64	77232A
340	191	90	32	28	0.66	77234A
360	202	95	32	28	0.69	77236A
380	213	100	34	29	0.72	77238A
400	225	106	34	29	0.75	77240A
420	238	112	35	30	0.79	77242A
440	247	116	36	31	0.82	77244A
460	259	122	36	31	0.86	77246A
480	270	127	37	32	0.89	77248A
500	283	133	37	32	0.93	77250A
520	293	138	38	33	0.97	77252A
540	306	144	38	33	1.01	77254A
560	317	149	38	33	1.06	77256A
580	329	155	39	34	1.10	77258A
600	338	159	39	34	1.15	77260A
620	351	165	41	35	1.20	77262A
640	361	170	41	35	1.25	77264A
660	374	176	42	36	1.31	77266A
680	385	181	42	36	1.37	77268A
700	397	187	42	36	1.43	77270A
720	408	192	43	37	1.49	77272A
740	421	198	43	37	1.55	77274A
760	431	203	43	37	1.62	77276A
780	444	209	44	38	1.69	77278A
800	453	213	44	38	1.76	77280A
820	465	219	45	39	1.84	77282A
840	476	224	45	39	1.92	77284A
860	487	229	45	39	2.00	77286A
880	499	235	46	40	2.09	77288A
900	510	240	46	40	2.18	77290A
960	544	256	47	41	2.33	77293A
1000	567	267	47	41	2.43	77295A
1100	623	293	50	43	2.70	77300A
1200	682	321	51	44	3.00	77305A
1300	737	347	53	46	3.34	77310A
1400	797	375	54	47	3.71	77315A
1500	852	401	56	48	4.00	77320A

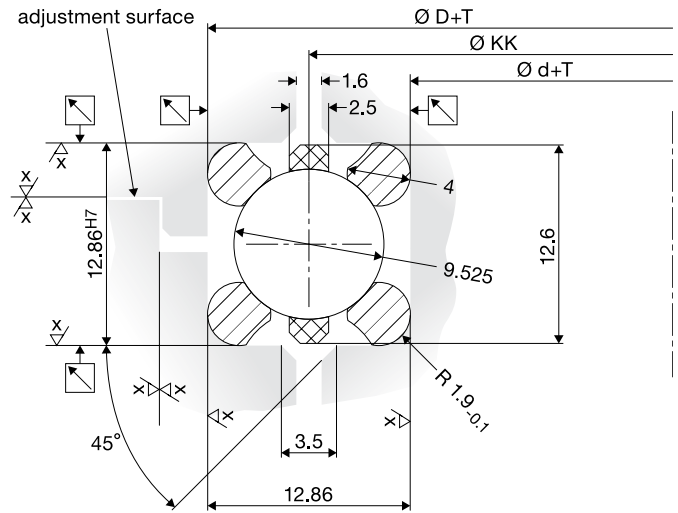

## Materials

	Race ring	Balls	Cage
<b>Standard</b>	54SiCr6	100Cr6 DIN 5401, G28	PA12
<b>Special</b>	Coating: Corrotect ATC	X45Cr13 POM Ceramic Al <sub>2</sub> O <sub>3</sub> Ceramic Si <sub>3</sub> N <sub>4</sub>	Non-corrosive Brass Bronze Teflon Laminate

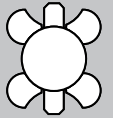

## LED 4/9.525 unground

Ø KK mm	Load ratings KN				Weight kg	Order no.
	Coa	Cor	Ca	Cr		
100	53	25	20	17	0.26	68310B
120	64	30	21	18	0.28	68314B
140	77	36	23	20	0.31	68318B
160	87	41	23	20	0.34	77202B
180	100	47	25	22	0.37	77206B
200	111	52	27	23	0.40	77210B
220	123	58	28	24	0.43	77214B
240	134	63	28	24	0.47	77218B
260	147	69	29	25	0.51	77222B
280	155	73	30	26	0.56	77226B
300	168	79	31	27	0.61	77230B
320	179	84	31	27	0.64	77232B
340	191	90	32	28	0.66	77234B
360	202	95	32	28	0.69	77236B
380	213	100	34	29	0.72	77238B
400	225	106	34	29	0.75	77240B
420	238	112	35	30	0.79	77242B
440	247	116	36	31	0.82	77244B
460	259	122	36	31	0.86	77246B
480	270	127	37	32	0.89	77248B
500	283	133	37	32	0.93	77250B
520	293	138	38	33	0.97	77252B
540	306	144	38	33	1.01	77254B
560	317	149	38	33	1.06	77256B
580	329	155	39	34	1.10	77258B
600	338	159	39	34	1.15	77260B
620	351	165	41	35	1.20	77262B
640	361	170	41	35	1.25	77264B
660	374	176	42	36	1.31	77266B
680	385	181	42	36	1.37	77268B
700	397	187	42	36	1.43	77270B
720	408	192	43	37	1.49	77272B
740	421	198	43	37	1.55	77274B
760	431	203	43	37	1.62	77276B
780	444	209	44	38	1.69	77278B
800	453	213	44	38	1.76	77280B
820	465	219	45	39	1.84	77282B
840	476	224	45	39	1.92	77284B
860	487	229	45	39	2.00	77286B
880	499	235	46	40	2.09	77288B
900	510	240	46	40	2.18	77290B
960	544	256	47	41	2.33	77293B
1000	567	267	47	41	2.43	77295B
1100	623	293	50	43	2.70	77300B
1200	682	321	51	44	3.00	77305B
1300	737	347	53	46	3.34	77310B
1400	797	375	54	47	3.71	77315B
1500	852	401	56	48	4.00	77320B

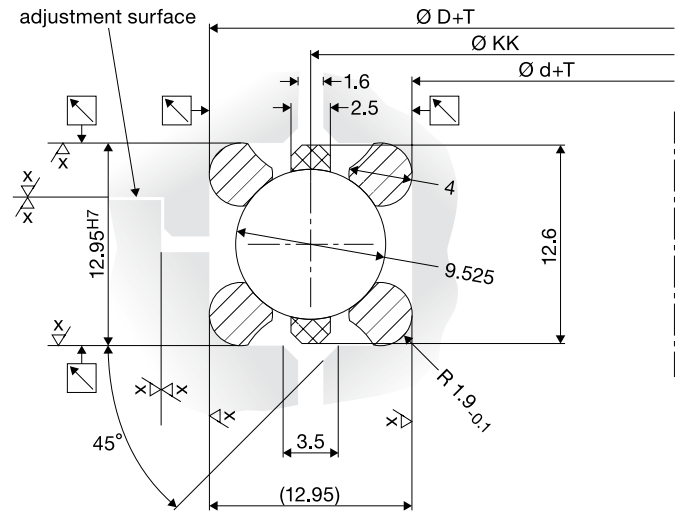

# Bearing Elements

## Type LER

Rectangular profile,  
unground raceways

### Materials

	Race ring	Balls	Cage
<b>Standard</b>	54SiCr6	100Cr6 DIN 5401, G28	PA12
<b>Special</b>	Coating: Corrotect ATC	Niro X45Cr13 POM Ceramic Al <sub>2</sub> O <sub>3</sub> Ceramic Si <sub>3</sub> N <sub>4</sub>	Non-corrosive Brass Bronze Teflon Laminate

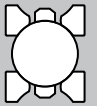

### LER 3

Ø KK mm	Load ratings KN				Weight kg	Order no.
	Coa	Cor	Ca	Cr		
100	53	25	20	17	0.2	68460A
120	64	30	21	18	0.2	68464A
140	77	36	23	20	0.2	68468A
160	87	41	23	20	0.3	74062A
180	100	47	25	22	0.3	74066A
200	111	52	27	23	0.3	74070A
220	123	58	28	24	0.4	74074A
240	134	63	28	24	0.4	74078A
260	147	69	29	25	0.4	74082A
280	155	73	30	26	0.4	74086A
300	168	79	31	27	0.5	74090A
320	179	84	31	27	0.5	74092A
340	191	90	32	28	0.5	74094A
360	202	95	32	28	0.5	74096A
380	213	100	34	29	0.5	74098A
400	225	106	34	29	0.7	74100A
420	238	112	35	30	0.7	74102A
440	247	116	36	31	0.7	74104A
460	259	122	36	31	0.7	74106A
480	270	127	37	32	0.7	74108A
500	283	133	37	32	0.8	74110A
520	293	138	38	33	0.9	74112A
540	306	144	38	33	0.9	74114A
560	317	149	38	33	1.0	74116A
580	329	155	39	34	1.0	74118A
600	338	159	39	34	1.1	74120A
620	351	165	41	35	1.1	74122A
640	361	170	41	35	1.2	74124A
660	374	176	42	36	1.2	74126A
680	385	181	42	36	1.3	74128A
700	397	187	42	36	1.3	74130A
720	408	192	43	37	1.4	74132A
740	421	198	43	37	1.5	74134A
760	431	203	43	37	1.5	74136A
780	444	209	44	38	1.6	74138A
800	453	213	44	38	1.6	74140A
820	465	219	45	39	1.7	74142A
840	476	224	45	39	1.7	74144A
860	487	229	45	39	1.8	74146A
880	499	235	46	40	1.8	74148A
900	510	240	46	40	1.9	74150A
960	544	256	47	41	2.0	74153A
1000	567	267	47	41	2.0	74155A
1100	623	293	50	43	2.2	74160A
1200	682	321	51	44	2.4	74165A
1300	737	347	53	46	2.6	74170A
1400	797	375	54	47	2.8	74175A
1500	852	401	56	48	3.0	74180A

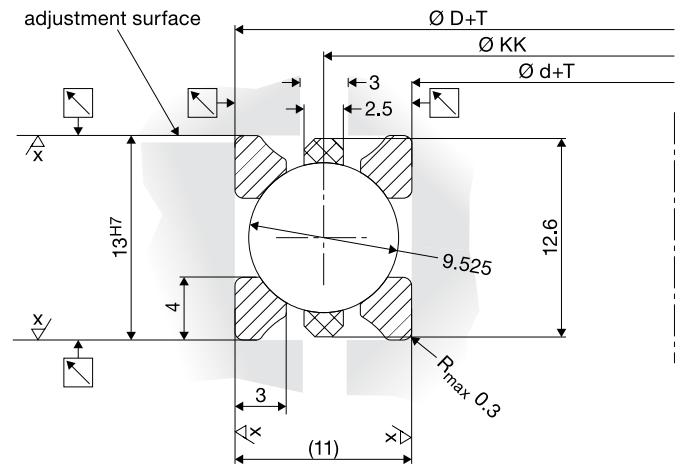

## Materials

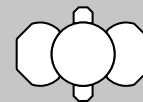

## Type LEG

2-ring bearing element,  
unground raceways

	Race ring	Balls	Cage
<b>Standard</b>	54SiCr6	100Cr6 DIN 5401, G28	PA12
<b>Special</b>	Coating: Corrotect ATC	Niro X45Cr13 POM Ceramic Al <sub>2</sub> O <sub>3</sub> Ceramic Si <sub>3</sub> N <sub>4</sub>	Non-corrosive Brass Bronze Teflon

## LEG

Ø KK mm	Load ratings KN				Weight kg	Order no.
	Coa	Cor	Ca	Cr		
100	20	19	7	11	0.09	68949A
120	23	23	7	12	0.10	68950A
140	27	27	8	12	0.12	68951A
160	32	31	8	13	0.14	68952A
180	35	35	8	14	0.15	68953A
200	39	40	9	14	0.17	68954A
220	44	43	9	15	0.19	68955A
240	48	47	9	15	0.20	68956A
260	52	51	10	16	0.22	68957A
280	56	55	10	16	0.24	68958A
300	60	59	10	16	0.26	68959A
320	64	63	10	17	0.27	68960A
340	68	67	11	17	0.29	68961A
360	72	71	11	18	0.31	68962A
380	76	75	11	18	0.32	68963A
400	80	79	11	18	0.34	68964A
420	84	83	12	19	0.36	68965A
440	88	87	12	19	0.38	68966A
460	92	91	12	19	0.39	68967A
480	96	95	12	20	0.41	68968A
500	100	99	12	20	0.43	68969A

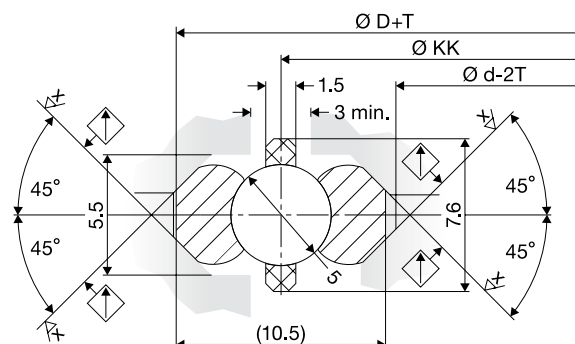

Please contact us if you wish to purchase a type LEG Bearing Element. We would be happy to create a suitable installation plan for you, in order to make effective use of this bearing.

# Slim Bearing

Type LDD

Bearing element  
with steel housing

## LDD 3/8"

Dimensions inch		Load ratings KN				Weight kg	Order no.
D	d	Coa	Cor	Ca	Cr		
5.50	4.75	51	24	17	15	0.15	<a href="#">75067A</a>
5.75	5.00	53	25	19	16	0.16	<a href="#">75068A</a>
6.25	5.50	60	28	19	16	0.16	<a href="#">75069A</a>
6.75	6.00	64	30	20	17	0.19	<a href="#">75070A</a>
7.25	6.50	70	33	20	17	0.21	<a href="#">75071A</a>
7.75	7.00	74	35	21	18	0.22	<a href="#">75072A</a>
8.25	7.50	79	37	21	18	0.24	<a href="#">75073A</a>
8.75	8.00	85	40	22	19	0.25	<a href="#">75074A</a>
9.75	9.00	96	45	23	20	0.29	<a href="#">75075A</a>
10.75	10.00	106	50	23	20	0.32	<a href="#">75076A</a>
11.75	11.00	115	54	24	21	0.35	<a href="#">75077A</a>
12.75	12.00	125	59	25	22	0.38	<a href="#">75078A</a>
14.75	14.00	147	69	27	23	0.44	<a href="#">75079A</a>
16.75	16.00	166	78	28	24	0.50	<a href="#">75080A</a>
18.75	18.00	187	88	29	25	0.56	<a href="#">75081A</a>
20.75	20.00	208	98	30	26	0.63	<a href="#">75082A</a>
25.75	25.00	259	122	32	28	0.78	<a href="#">75083A</a>

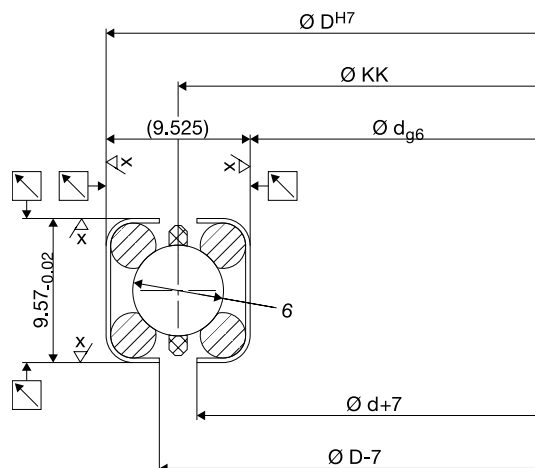

## LDD 1/2"

Dimensions inch		Load ratings KN				Weight kg	Order no.
D	d	Coa	Cor	Ca	Cr		
7.00	6.00	70	33	31	27	0.34	<a href="#">75010A</a>
7.50	6.50	74	35	32	28	0.36	<a href="#">75011A</a>
8.00	7.00	79	37	34	29	0.39	<a href="#">75012A</a>
8.50	7.50	87	41	35	30	0.42	<a href="#">75013A</a>
9.00	8.00	91	43	35	30	0.45	<a href="#">75014A</a>
10.00	9.00	102	48	36	31	0.50	<a href="#">75015A</a>
11.00	10.00	113	53	37	32	0.56	<a href="#">75016A</a>
12.00	11.00	123	58	39	34	0.61	<a href="#">75017A</a>
13.00	12.00	136	64	41	35	0.66	<a href="#">75018A</a>
15.00	14.00	157	74	43	37	0.77	<a href="#">75019A</a>
17.00	16.00	179	84	45	39	0.88	<a href="#">75020A</a>
19.00	18.00	202	95	46	40	0.99	<a href="#">75021A</a>
21.00	20.00	223	105	49	42	1.09	<a href="#">75022A</a>
26.00	25.00	278	131	52	45	1.36	<a href="#">75023A</a>

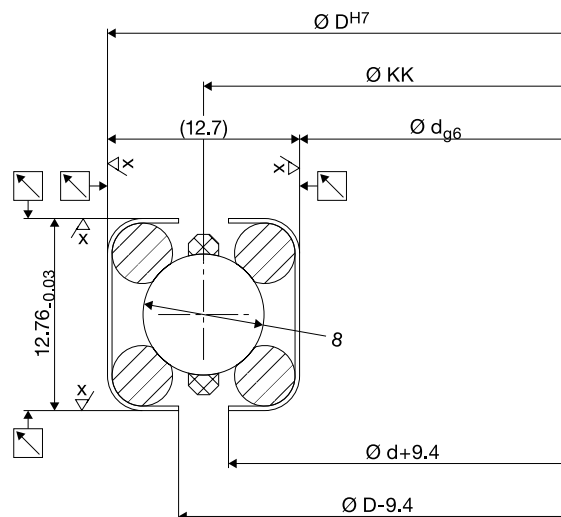

Materials

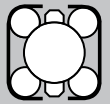

	Housings	Race ring	Balls	Cage
<b>Standard</b>	Ck55	54SiCr6	100Cr6 DIN 5401, G28	PA12
<b>Special</b>	Coating: ATC	Niro X12CrNi177 Niro X7CrNiAl177	Niro X45Cr13 POM Ceramic Al <sub>2</sub> O <sub>3</sub> Ceramic Si <sub>3</sub> N <sub>4</sub>	

LDD 3/4“

Dimensions inch		Load ratings KN				Weight kg	Order no.
D	d	Coa	Cor	Ca	Cr		
8.50	7.00	155	73	84	73	0.89	75032A
9.00	7.50	166	78	87	75	0.95	75033A
9.50	8.00	174	82	89	77	1.01	75034A
10.50	9.00	196	92	93	80	1.13	75035A
11.50	10.00	219	103	97	84	1.26	75036A
12.50	11.00	238	112	101	87	1.38	75037A
13.50	12.00	257	121	103	89	1.49	75038A
15.50	14.00	302	142	110	95	1.74	75039A
17.50	16.00	340	160	116	100	1.97	75040A
19.50	18.00	383	180	119	103	2.22	75041A
21.50	20.00	427	201	125	108	2.47	75042A
26.50	25.00	529	249	134	116	3.07	75043A

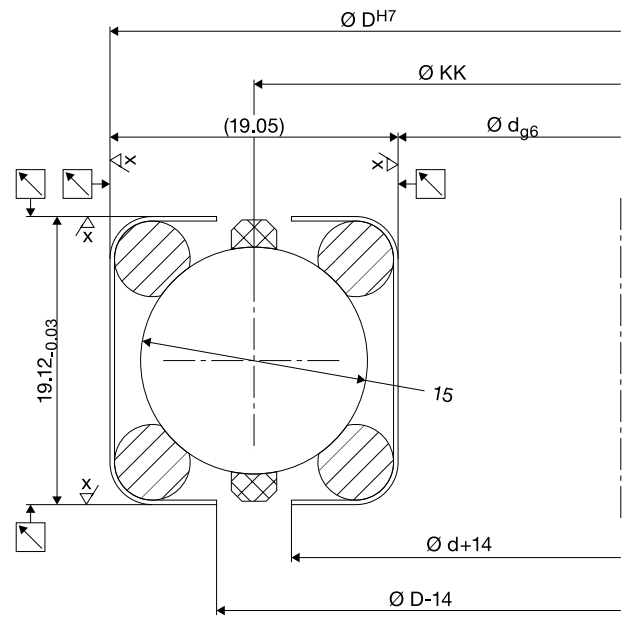

LDD 1“

Dimensions inch		Load ratings KN				Weight kg	Order no.
D	d	Coa	Cor	Ca	Cr		
10.00	8.00	270	127	136	118	1.81	75054A
11.00	9.00	300	141	143	124	2.01	75055A
12.00	10.00	332	156	148	128	2.26	75056A
13.00	11.00	361	170	154	133	2.47	75057A
14.00	12.00	391	184	158	137	2.67	75058A
16.00	14.00	463	218	169	146	3.09	75059A
18.00	16.00	525	247	178	154	3.54	75060A
20.00	18.00	587	276	185	160	3.96	75061A
22.00	20.00	648	305	192	166	4.41	75062A
27.00	25.00	803	378	207	179	5.45	75063A

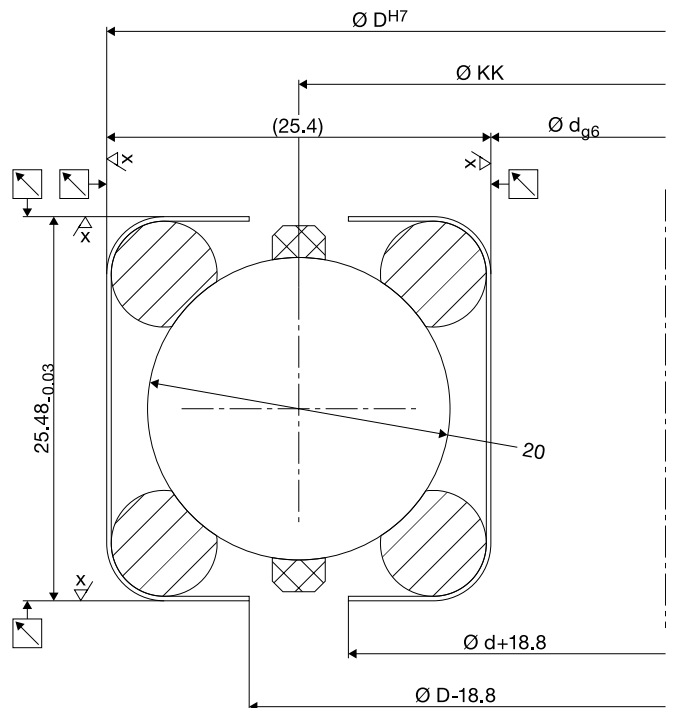

# Bearing Assemblies

Type LDL

Steel version

## LDL steel

Ø KK mm	Dimensions mm							
	D	d	h1	h2	k1	s	SD	t1
100- 220	11	6.6	30	24	6.8	15.0	M 6	10
240- 280	15	9.0	34	27	9.0	17.5	M 8	15
300- 380	15	9.0	38	31	9.0	19.5	M 8	15
400- 480	18	11.0	44	37	11.0	22.5	M10	15
500- 600	20	14.0	49	42	13.0	25.0	M12	20
620- 780	20	14.0	53	45	13.0	29.0	M12	20
800-1500	26	18.0	60	52	17.5	33.0	M16	25

## Bore shape A

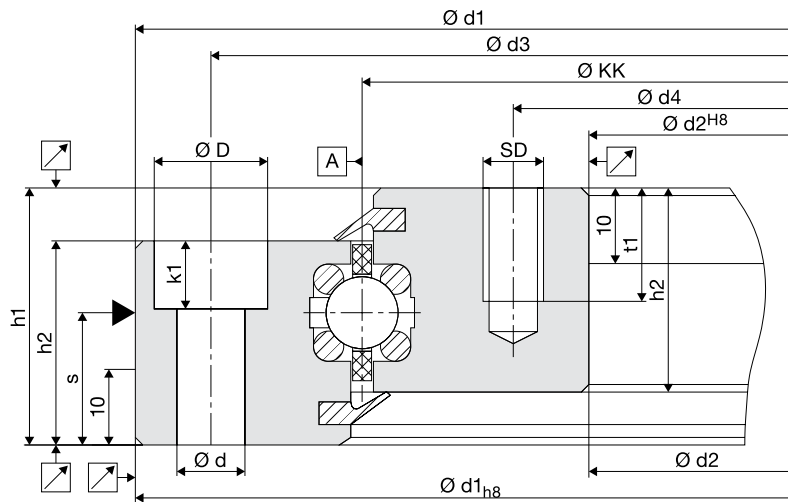

## Bore shape B

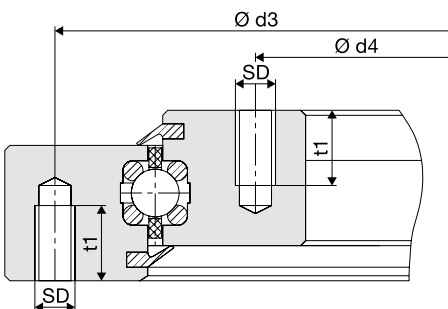

## Bore shape C

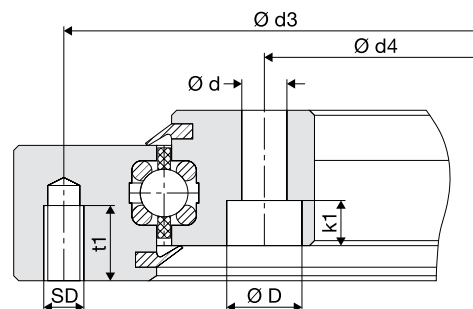



Materials

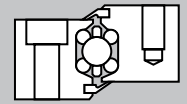

	Inner / Outer ring	Race ring	Balls	Cage	Seals
<b>Standard</b>	C45N	54SiCr6	100Cr6	PA12	NBR
<b>Special</b>	Niro X5CrNi18.10 Brass CuSn12 Plastic Magnesium Coatings	Niro X12CrNi177 Niro X7CrNi177 Duratherm Coating: Corrotect ATC	Niro X45Cr13 POM Ceramic Al <sub>2</sub> O <sub>3</sub> Ceramic Si <sub>3</sub> N <sub>4</sub>	Non-corrosive Bronze Laminate Brass Teflon	Viton Teflon Labyrinth Metal seal

Ø KK mm	Diameter mm				Fixing per ring	Load rating KN				Weight kg	Order no. Bore shape		
	d1	d2	d3	d4		Coa	Cor	Ca	Cr		A	B	C
100	150	50	135	65	6x	53	25	20	17	2.5	66401Y	66402Y	66403Y
120	170	70	155	85	6x	66	31	20	17	3.0	69703Y	69704Y	69705Y
140	190	90	175	105	6x	79	37	20	17	3.5	69709Y	69710Y	69711Y
160	210	110	195	125	6x	91	43	21	18	4.0	73003Y	73004Y	73005Y
180	230	130	215	145	8x	104	49	22	19	4.5	73009Y	73010Y	73011Y
200	250	150	235	165	8x	115	54	23	20	5.0	73015Y	73016Y	73017Y
220	270	170	255	185	8x	128	60	24	21	5.5	73021Y	73022Y	73023Y
240	300	180	280	200	8x	142	67	28	24	8.1	73027Y	73028Y	73029Y
260	320	200	300	220	10x	155	73	29	25	8.8	73033Y	73034Y	73035Y
280	340	220	320	240	10x	166	78	30	26	9.4	73039Y	73040Y	73041Y
300	360	240	340	260	12x	179	84	31	27	11.6	73045Y	73046Y	73047Y
320	380	260	360	280	12x	191	90	31	27	12.4	73051Y	73052Y	73053Y
340	400	280	380	300	14x	204	96	32	28	13.2	73057Y	73058Y	73059Y
360	420	300	400	320	14x	215	101	32	28	13.9	73063Y	73064Y	73065Y
380	440	320	420	340	14x	227	107	34	29	14.7	73069Y	73070Y	73071Y
400	470	330	445	355	14x	272	128	32	28	21.6	73075Y	73076Y	73077Y
420	490	350	465	375	14x	289	136	32	28	22.7	73081Y	73082Y	73083Y
440	510	370	485	395	14x	302	142	34	29	23.7	73087Y	73088Y	73089Y
460	530	390	505	415	14x	317	149	34	29	24.8	73093Y	73094Y	73095Y
480	550	410	525	435	14x	329	155	35	30	25.9	73099Y	73100Y	73101Y
500	580	420	550	450	14x	344	162	35	30	35.0	73105Y	73106Y	73107Y
520	600	440	570	470	14x	357	168	36	31	36.4	73111Y	73112Y	73113Y
540	620	460	590	490	16x	372	175	36	31	37.8	73117Y	73118Y	73119Y
560	640	480	610	510	16x	385	181	36	31	39.2	73123Y	73124Y	73125Y
580	660	500	630	530	16x	400	188	37	32	40.6	73129Y	73130Y	73131Y
600	680	520	650	550	16x	412	194	37	32	42.0	73135Y	73136Y	73137Y
620	710	530	670	570	22x	701	330	87	75	56.9	66141A	66142A	66143A
640	730	550	690	590	22x	725	341	88	76	58.8	66144A	66145A	66146A
660	750	570	710	610	22x	746	351	89	77	60.7	66147A	66148A	66149A
680	770	590	730	630	22x	767	361	90	78	62.5	66150A	66151A	66152A
700	790	610	750	650	22x	788	371	91	79	64.4	66153A	66154A	66155A
720	810	630	770	670	22x	818	385	93	80	66.3	66156A	66157A	66158A
740	830	650	790	690	24x	842	396	94	81	68.0	66159A	66160A	66161A
760	850	670	810	710	24x	863	406	94	81	69.9	66162A	66163A	66164A
780	870	690	830	730	24x	884	416	95	82	71.8	66165A	66166A	66167A
800	900	700	865	735	24x	1056	497	120	104	93.9	66168A	66169A	66170A
820	920	720	885	755	24x	1090	513	123	106	96.3	66171A	66172A	66173A
840	940	740	905	775	24x	1111	523	123	106	98.7	66174A	66175A	66176A
860	960	760	925	795	24x	1135	534	124	107	101.1	66177A	66178A	66179A
880	980	780	945	815	24x	1167	549	125	108	103.5	66180A	66181A	66182A
900	1000	800	965	835	24x	1190	560	126	109	105.9	66183A	66184A	66185A
960	1060	860	1025	895	26x	1267	596	130	112	113.0	66192A	66193A	66194A
1000	1100	900	1065	935	26x	1324	623	131	113	117.8	66198A	66199A	66200A
1100	1200	1000	1165	1035	30x	1411	664	133	115	129.6	66386A	66387A	66388A
1200	1300	1100	1265	1135	30x	1587	747	140	121	141.6	66389A	66390A	66391A
1300	1400	1200	1365	1235	36x	1698	799	143	124	153.1	66392A	66393A	66394A
1400	1500	1300	1465	1335	36x	1853	872	148	128	165.1	66395A	66396A	66397A
1500	1600	1400	1565	1435	40x	1942	914	149	129	177.0	66398A	66399A	66400A

# Bearing Assemblies

Type LDL

Aluminium version (anodized)

## LDL aluminium

Ø KK mm	Dimensions mm							
	D	d	h1	h2	k1	s	SD	t1
100- 220	11	6.6	30	24	6.8	15.0	M 6	10
240- 280	15	9.0	34	27	9.0	17.5	M 8	15
300- 380	15	9.0	38	31	9.0	19.5	M 8	15
400- 480	18	11.0	44	37	11.0	22.5	M10	15
500- 600	20	14.0	49	42	13.0	25.0	M12	20
620- 780	20	14.0	53	45	13.0	29.0	M12	20
800-1500	26	18.0	60	52	17.5	33.0	M16	25

## Bore shape A

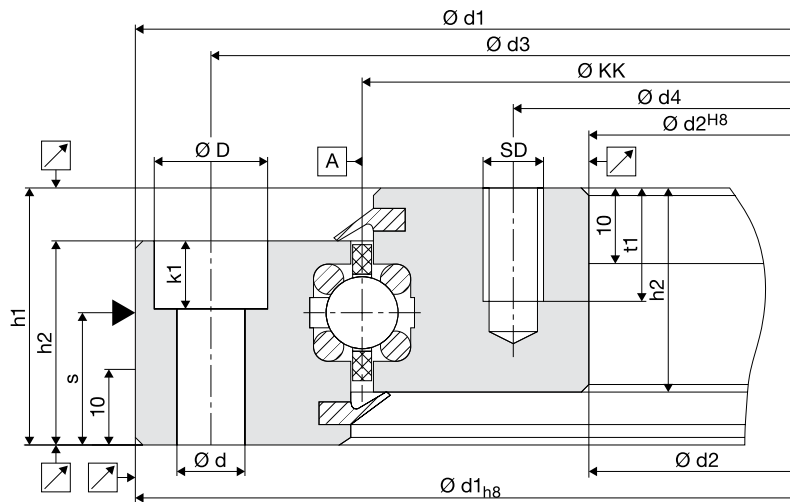

## Bore shape B

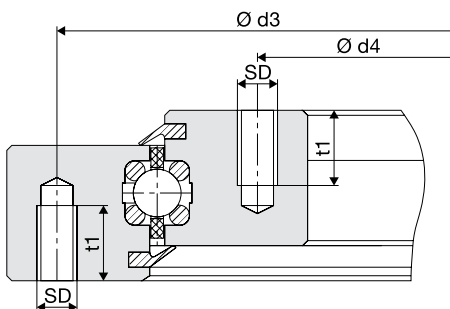

## Bore shape C

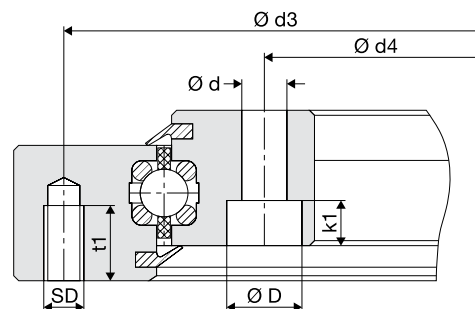

Materials

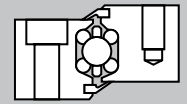

	Inner / Outer ring	Race ring	Balls	Cage	Seals
<b>Standard</b>	AlZnMgCu05	54SiCr6	100Cr6	PA12	NBR
<b>Special</b>	Niro X5CrNi18.10 Brass CuSn12 Plastic Magnesium Coatings	Niro X12CrNi177 Niro X7CrNi177 Duratherm Coating: Corrotect ATC	Niro X45Cr13 POM Ceramic Al <sub>2</sub> O <sub>3</sub> Ceramic Si <sub>3</sub> N <sub>4</sub>	Non-corrosive Bronze Laminate Brass Teflon	Viton Teflon Labyrinth Metal seal

Ø KK mm	Diameter mm				Fixing per ring	Load rating KN				Weight kg	Order no. Bore shape		
	d1	d2	d3	d4		Coa	Cor	Ca	Cr		A	B	C
100	150	50	135	65	6x	53	25	20	17	1.0	66401L	66402L	66403L
120	170	70	155	85	6x	66	31	20	17	1.2	69703L	69704L	69705L
140	190	90	175	105	6x	79	37	20	17	1.4	69709L	69710L	69711L
160	210	110	195	125	6x	91	43	21	18	1.6	73003L	73004L	73005L
180	230	130	215	145	8x	104	49	22	19	1.8	73009L	73010L	73011L
200	250	150	235	165	8x	115	54	23	20	2.0	73015L	73016L	73017L
220	270	170	255	185	8x	128	60	24	21	2.2	73021L	73022L	73023L
240	300	180	280	200	8x	142	67	28	24	3.1	73027L	73028L	73029L
260	320	200	300	220	10x	155	73	29	25	3.4	73033L	73034L	73035L
280	340	220	320	240	10x	166	78	30	26	3.6	73039L	73040L	73041L
300	360	240	340	260	12x	179	84	31	27	4.5	73045L	73046L	73047L
320	380	260	360	280	12x	191	90	31	27	4.8	73051L	73052L	73053L
340	400	280	380	300	14x	204	96	32	28	5.1	73057L	73058L	73059L
360	420	300	400	320	14x	215	101	32	28	5.4	73063L	73064L	73065L
380	440	320	420	340	14x	227	107	34	29	5.7	73069L	73070L	73071L
400	470	330	445	355	14x	272	128	32	28	8.0	73075L	73076L	73077L
420	490	350	465	375	14x	289	136	32	28	8.4	73081L	73082L	73083L
440	510	370	485	395	14x	302	142	34	29	8.8	73087L	73088L	73089L
460	530	390	505	415	14x	317	149	34	29	9.2	73093L	73094L	73095L
480	550	410	525	435	14x	329	155	35	30	9.6	73099L	73100L	73101L
500	580	420	550	450	14x	344	162	35	30	13.0	73105L	73106L	73107L
520	600	440	570	470	14x	357	168	36	31	13.5	73111L	73112L	73113L
540	620	460	590	490	16x	372	175	36	31	14.0	73117L	73118L	73119L
560	640	480	610	510	16x	385	181	36	31	14.5	73123L	73124L	73125L
580	660	500	630	530	16x	400	188	37	32	15.0	73129L	73130L	73131L
600	680	520	650	550	16x	412	194	37	32	15.6	73135L	73136L	73137L
620	710	530	670	570	22x	701	330	87	75	21.1	66141L	66142L	66143L
640	730	550	690	590	22x	725	341	88	76	21.8	66144L	66145L	66146L
660	750	570	710	610	22x	746	351	89	77	22.5	66147L	66148L	66149L
680	770	590	730	630	22x	767	361	90	78	23.2	66150L	66151L	66152L
700	790	610	750	650	22x	788	371	91	79	23.9	66153L	66154L	66155L
720	810	630	770	670	22x	818	385	93	80	24.6	66156L	66157L	66158L
740	830	650	790	690	24x	842	396	94	81	25.2	66159L	66160L	66161L
760	850	670	810	710	24x	863	406	94	81	25.9	66162L	66163L	66164L
780	870	690	830	730	24x	884	416	95	82	26.6	66165L	66166L	66167L
800	900	700	865	735	24x	1056	497	120	104	36.1	66168L	66169L	66170L
820	920	720	885	755	24x	1090	513	123	106	37.0	66171L	66172L	66173L
840	940	740	905	775	24x	1111	523	123	106	38.0	66174L	66175L	66176L
860	960	760	925	795	24x	1135	534	124	107	38.9	66177L	66178L	66179L
880	980	780	945	815	24x	1167	549	125	108	39.9	66180L	66181L	66182L
900	1000	800	965	835	24x	1190	560	126	109	40.8	66183L	66184L	66185L
960	1060	860	1025	895	26x	1267	596	130	112	43.5	66192L	66193L	66194L
1000	1100	900	1065	935	26x	1324	623	131	113	45.3	66198L	66199L	66200L
1100	1200	1000	1165	1035	30x	1411	664	133	115	49.9	66386L	66387L	66388L
1200	1300	1100	1265	1135	30x	1587	747	140	121	54.5	66389L	66390L	66391L
1300	1400	1200	1365	1235	36x	1698	799	143	124	58.9	66392L	66393L	66394L
1400	1500	1300	1465	1335	36x	1853	872	148	128	63.5	66395L	66396L	66397L
1500	1600	1400	1565	1435	40x	1942	914	149	129	68.4	66398L	66399L	66400L

# Bearing Assemblies

Type LDL

Steel version  
with inner gear

## LDL inner gear

Ø KK mm	Dimensions mm								
	D	d	h1	h2	b	k1	s	SD	t1
100- 220	11	6.6	30	24	19	6.8	15.0	M 6	10
240- 280	15	9.0	34	27	22	9.0	17.5	M 8	15
300- 380	15	9.0	38	31	26	9.0	19.5	M 8	15
400- 480	18	11.0	44	37	32	11.0	22.5	M10	15
500- 600	20	14.0	49	42	35	13.0	25.0	M12	20
620- 780	20	14.0	53	45	38	13.0	29.0	M12	20
800-1500	26	18.0	60	52	45	17.5	33.0	M16	25

## Bore shape A

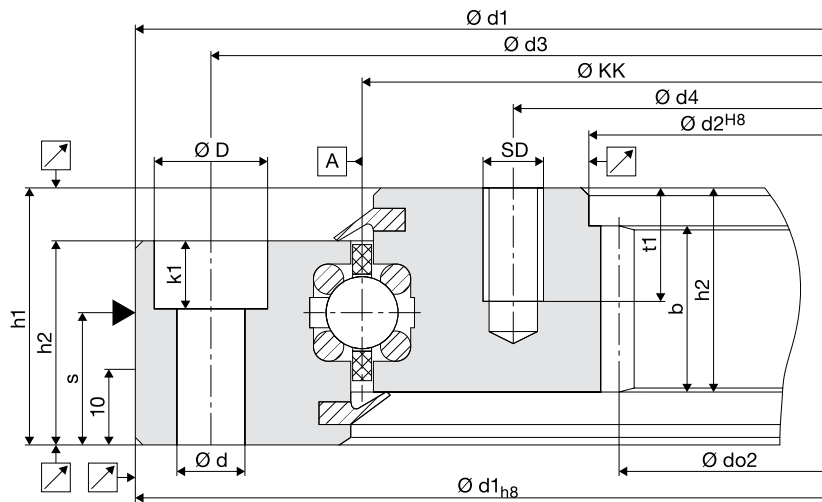

## Bore shape B

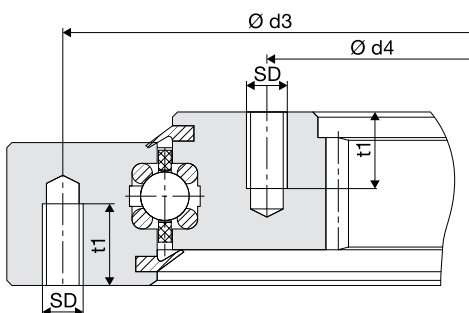

## Bore shape C

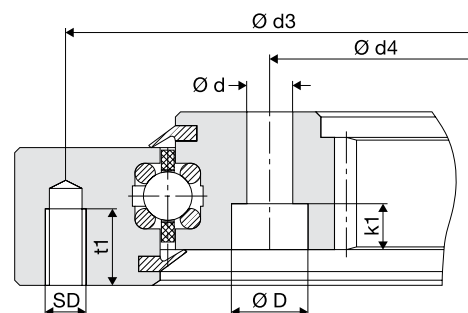

Materials

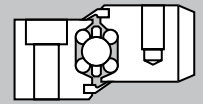

	Inner / Outer ring	Race ring	Balls	Cage	Seals	Gears
<b>Standard</b>	42CrMo4V C45N	54SiCr6	100Cr6	PA12	NBR	DIN 3967 Quality 8e25 Basic profile DIN 867
<b>Special</b>	Niro X5CrNi18.10 Brass CuSn12 Plastic Magnesium Coatings	Niro X12CrNi177 Niro X7CrNi177 Duratherm Coating: Corroctect ATC	Niro X45Cr13 POM Ceramic Al <sub>2</sub> O <sub>3</sub> Ceramic Si <sub>3</sub> N <sub>4</sub>	Non-corrosive Bronze Laminate Brass Teflon	Viton Teflon Labyrinth Metal seal	other gears on request

Ø KK mm	Module m	Dimensions mm		Teeth number Z	Permit. peripheral forces KN		Order no. Bore shape		
		d02	d2		Standard	Max.	A	B	C
100	2	40	50	20	4.47	8.94	66401W	66402W	66403W
120	2	60	70	30	4.00	8.00	69703W	69704W	69705W
140	2	80	90	40	3.80	7.60	69709W	69710W	69711W
160	2	100	110	50	3.62	7.24	73003W	73004W	73005W
180	2	120	130	60	3.62	7.24	73009W	73010W	73011W
200	2	140	150	70	3.45	6.90	73015W	73016W	73017W
220	2	160	170	80	3.45	6.90	73021W	73022W	73023W
240	2	170	180	85	4.00	8.00	73027W	73028W	73029W
260	2	190	200	95	3.83	7.65	73033W	73034W	73035W
280	2	210	220	105	3.83	7.65	73039W	73040W	73041W
300	3	228	240	76	7.09	14.18	73045W	73046W	73047W
320	3	249	260	83	7.09	14.18	73051W	73052W	73053W
340	3	264	280	88	7.09	14.18	73057W	73058W	73059W
360	3	288	300	96	6.78	13.57	73063W	73064W	73065W
380	3	306	320	102	6.78	13.57	73069W	73070W	73071W
400	3	318	330	106	8.35	16.70	73075W	73076W	73077W
420	3	336	350	112	8.35	16.70	73081W	73082W	73083W
440	3	357	370	119	8.35	16.70	73087W	73088W	73089W
460	3	378	390	126	8.17	16.34	73093W	73094W	73095W
480	3	396	410	132	8.17	16.34	73099W	73100W	73101W
500	3	408	420	136	8.90	17.80	73105W	73106W	73107W
520	3	426	440	142	8.90	17.80	73111W	73112W	73113W
540	3	444	460	148	8.86	17.72	73117W	73118W	73119W
560	3	468	480	156	8.86	17.72	73123W	73124W	73125W
580	3	486	500	162	8.82	17.65	73129W	73130W	73131W
600	3	507	520	169	8.82	17.65	73135W	73136W	73137W
620	4	512	530	128	12.94	25.87	66141W	66142W	66143W
640	4	532	550	133	12.94	25.87	66144W	66145W	66146W
660	4	552	570	138	12.88	25.76	66147W	66148W	66149W
680	4	572	590	143	12.88	25.76	66150W	66151W	66152W
700	4	592	610	148	12.83	25.65	66153W	66154W	66155W
720	4	612	630	153	12.83	25.65	66156W	66157W	66158W
740	4	632	650	158	12.83	25.65	66159W	66160W	66161W
760	4	648	670	162	12.77	25.55	66162W	66163W	66164W
780	4	672	690	168	12.77	25.55	66165W	66166W	66167W
800	5	680	700	136	19.07	38.14	66168W	66169W	66170W
820	5	700	720	140	19.07	38.14	66171W	66172W	66173W
840	5	720	740	144	19.07	38.14	66174W	66175W	66176W
860	5	740	760	148	18.99	37.97	66177W	66178W	66179W
880	5	760	780	152	18.99	37.97	66180W	66181W	66182W
900	5	780	800	156	18.99	37.97	66183W	66184W	66185W
960	5	840	860	168	18.91	37.82	66192W	66193W	66194W
1000	5	880	900	176	18.83	37.66	66198W	66199W	66200W
1100	5	980	1000	196	18.75	37.50	66386W	66387W	66388W
1200	5	1080	1100	216	18.75	37.50	66389W	66390W	66391W
1300	5	1180	1200	236	18.75	37.50	66392W	66393W	66394W
1400	5	1280	1300	256	18.75	37.50	66395W	66396W	66397W
1500	5	1380	1400	276	18.75	37.50	66398W	66399W	66400W

Load rating and other dimensions as for type LDL steel design (page 41).  
Other diameters and in-between sizes available on request.

# Bearing Assemblies

Type LDL

Steel version  
with outer gear

## LDL outer gear

Ø KK mm	Dimensions mm									
	D	d	h1	h2	b	k1	s	SD	t1	
100- 220	11	6.6	30	24	19	6.8	15.0	M 6	10	
240- 280	15	9.0	34	27	22	9.0	17.5	M 8	15	
300- 380	15	9.0	38	31	26	9.0	19.5	M 8	15	
400- 480	18	11.0	44	37	32	11.0	22.5	M10	15	
500- 600	20	14.0	49	42	35	13.0	25.0	M12	20	
620- 780	20	14.0	53	45	38	13.0	29.0	M12	20	
800-1500	26	18.0	60	52	45	17.5	33.0	M16	25	

## Bore shape A

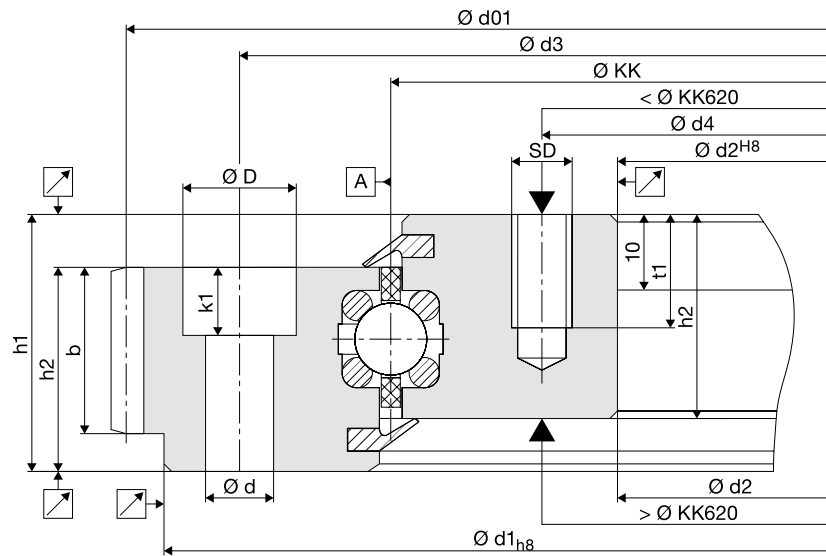

## Bore shape B

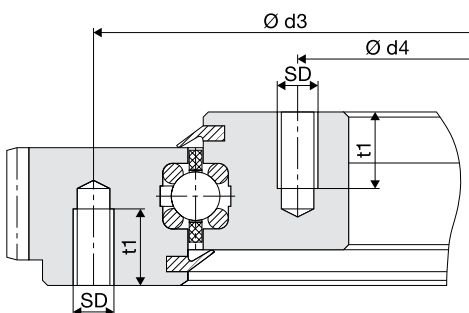

## Bore shape C

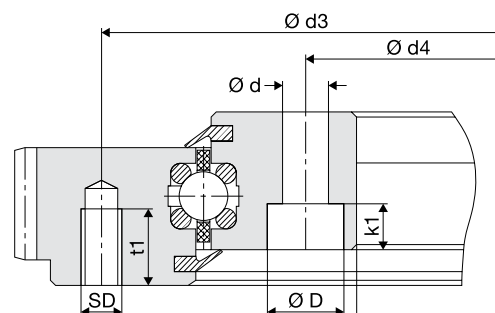

## Materials

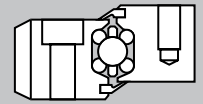

	Inner / Outer ring	Race ring	Balls	Cage	Seals	Gears
<b>Standard</b>	C45N 42CrMo4V	54SiCr6	100Cr6	PA12	NBR	DIN 3967 Quality 8e25 Basic profile DIN 867
<b>Special</b>	Niro X5CrNi18.10 Brass CuSn12 Plastic Magnesium Coatings	Niro X12CrNi177 Niro X7CrNi177 Duratherm Coating: Corroctect ATC	Niro X45Cr13 POM Ceramic Al <sub>2</sub> O <sub>3</sub> Ceramic Si <sub>3</sub> N <sub>4</sub>	Non-corrosive Bronze Laminate Brass Teflon	Viton Teflon Labyrinth Metal seal	other gears on request

Ø KK mm	Module m	Dimensions mm		Teeth number Z	Permit. peripheral forces KN		Order no. Bore shape		
		d01	d1		Standard	Max.	A	B	C
100	2	160	150	80	2.92	5.85	66401V	66402V	66403V
120	2	180	170	90	2.92	5.85	69703V	69704V	69705V
140	2	200	190	100	3.04	6.08	69709V	69710V	69711V
160	2	220	210	110	3.04	6.08	73003V	73004V	73005V
180	2	240	230	120	3.04	6.08	73009V	73010V	73011V
200	2	260	250	130	3.04	6.08	73015V	73016V	73017V
220	2	280	270	140	3.04	6.08	73021V	73022V	73023V
240	2	310	300	155	3.52	7.04	73027V	73028V	73029V
260	2	330	320	165	3.52	7.04	73033V	73034V	73035V
280	2	350	340	175	3.52	7.04	73039V	73040V	73041V
300	3	372	360	124	6.24	12.48	73045V	73046V	73047V
320	3	396	380	132	6.24	12.48	73051V	73052V	73053V
340	3	414	400	138	6.24	12.48	73057V	73058V	73059V
360	3	432	420	144	6.24	12.48	73063V	73064V	73065V
380	3	456	440	152	6.24	12.48	73069V	73070V	73071V
400	3	483	470	161	7.68	15.36	73075V	73076V	73077V
420	3	504	490	168	7.68	15.36	73081V	73082V	73083V
440	3	522	510	174	7.68	15.36	73087V	73088V	73089V
460	3	546	530	182	7.68	15.36	73093V	73094V	73095V
480	3	564	550	188	7.68	15.36	73099V	73100V	73101V
500	3	594	580	189	8.40	16.80	73105V	73106V	73107V
520	3	612	600	204	8.40	16.80	73111V	73112V	73113V
540	3	636	620	212	8.40	16.80	73117V	73118V	73119V
560	3	654	640	218	8.40	16.80	73123V	73124V	73125V
580	3	672	660	224	8.40	16.80	73129V	73130V	73131V
600	3	693	680	231	8.40	16.80	73135V	73136V	73137V
620	4	728	710	182	12.16	24.32	66141V	66142V	66143V
640	4	748	730	187	12.16	24.32	66144V	66145V	66146V
660	4	768	750	192	12.16	24.32	66147V	66148V	66149V
680	4	792	770	198	12.16	24.32	66150V	66151V	66152V
700	4	808	790	202	12.16	24.32	66153V	66154V	66155V
720	4	828	810	207	12.16	24.32	66156V	66157V	66158V
740	4	848	830	212	12.16	24.32	66159V	66160V	66161V
760	4	868	850	217	12.16	24.32	66162V	66163V	66164V
780	4	888	870	222	12.16	24.32	66165V	66166V	66167V
800	5	920	900	184	18.00	36.00	66168V	66169V	66170V
820	5	940	920	188	18.00	36.00	66171V	66172V	66173V
840	5	960	940	192	18.00	36.00	66174V	66175V	66176V
860	5	980	960	196	18.00	36.00	66177V	66178V	66179V
880	5	1000	980	200	18.00	36.00	66180V	66181V	66182V
900	5	1020	1000	204	18.00	36.00	66183V	66184V	66185V
960	5	1080	1060	216	18.00	36.00	66192V	66193V	66194V
1000	5	1120	1100	224	18.00	36.00	66198V	66199V	66200V
1100	5	1220	1200	244	18.00	36.00	66386V	66387V	66388V
1200	5	1320	1300	264	18.00	36.00	66389V	66390V	66391V
1300	5	1420	1400	284	18.00	36.00	66392V	66393V	66394V
1400	5	1520	1500	304	18.00	36.00	66395V	66396V	66397V
1500	5	1620	1600	324	18.00	36.00	66398V	66399V	66400V

Load rating and other dimensions as for type LDL steel design (page 41).  
Other diameters and in-between sizes available on request.

# Bearing Assemblies

Type LDL

Aluminium version (anodized)  
with toothed belt gear

## LDL toothed belt gear

Ø KK mm	Dimensions mm						
	D	d	h1	h2	k1	SD	t1
100- 220	11	6.6	30	24	6.8	M 6	10
230- 290	15	9.0	34	27	9.0	M 8	15
300- 380	15	9.0	38	31	9.0	M 8	15
400- 480	18	11.0	44	37	11.0	M10	15
500- 600	20	14.0	49	42	13.0	M12	20
620- 780	20	14.0	53	45	13.0	M12	20
800-1500	26	18.0	60	52	17.5	M16	25

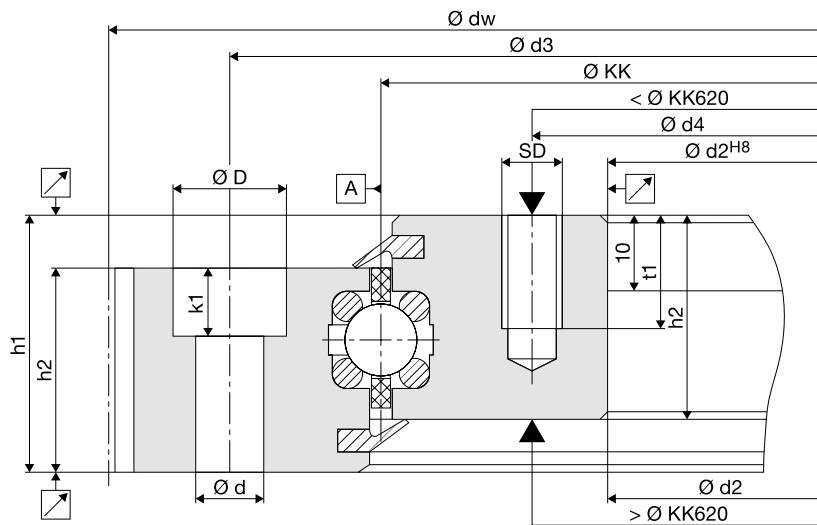

Profile T10

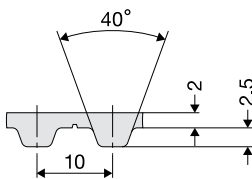

Profile AT10

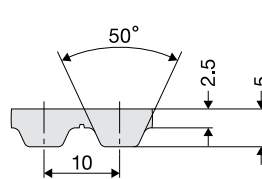

Profile HTD8

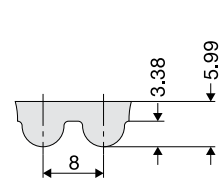



## Materials

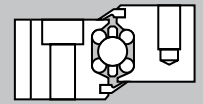

	Inner / Outer ring	Race ring	Balls	Cage	Seals
<b>Standard</b>	AlZnMgCu05	54SiCr6	100Cr6	PA12	NBR
<b>Special</b>	Niro X5CrNi18.10 Brass CuSn12 Plastic Magnesium Coatings	Niro X12CrNi177 Niro X7CrNi177 Duratherm Coating: Corrotect ATC	Niro X45Cr13 POM Ceramic Al <sub>2</sub> O <sub>3</sub> Ceramic Si <sub>3</sub> N <sub>4</sub>	Non-corrosive Bronze Laminate Brass Teflon	Viton Teflon Labyrinth Metal seal

**Gear types:** also available as T5, AT5, HTD3, HTD14, T20, AT20

Ø KK mm	Dimensions mm			Effective pulley diameter dw				Order no. Gear Bore shape A		
	d2	d3	d4	mm T10/AT10	teeth number z	mm HTD8	teeth number z	T10	AT10	HTD8
100	50	135	65	159.15	50	160.43	63	66401LZ	66402LZ	66403LZ
120	70	155	85	178.25	56	178.25	70	69703LZ	69704LZ	69705LZ
140	90	175	105	200.54	63	198.63	78	69709LZ	69710LZ	69711LZ
160	110	195	125	219.63	69	219.00	86	73003LZ	73004LZ	73005LZ
180	130	215	145	238.73	75	236.82	93	73009LZ	73010LZ	73011LZ
200	150	235	165	261.01	82	259.74	102	73015LZ	73016LZ	73017LZ
220	170	255	185	280.11	88	280.11	110	73021LZ	73022LZ	73023LZ
240	180	280	200	311.94	98	310.67	122	73027LZ	73028LZ	73029LZ
260	200	300	220	331.04	104	331.04	130	73033LZ	73034LZ	73035LZ
280	220	320	240	350.14	110	348.87	137	73039LZ	73040LZ	73041LZ
300	240	340	260	372.42	117	371.79	146	73045LZ	73046LZ	73047LZ
320	260	360	280	394.70	124	394.70	155	73051LZ	73052LZ	73053LZ
340	280	380	300	413.80	130	412.53	162	73057LZ	73058LZ	73059LZ
360	300	400	320	432.90	136	430.35	169	73063LZ	73064LZ	73065LZ
380	320	420	340	455.18	143	453.27	178	73069LZ	73070LZ	73071LZ
400	330	445	355	480.65	151	478.74	188	73075LZ	73076LZ	73077LZ
420	350	465	375	502.93	158	501.66	197	73081LZ	73082LZ	73083LZ
440	370	485	395	522.03	164	522.03	205	73087LZ	73088LZ	73089LZ
460	390	505	415	544.31	171	542.40	213	73093LZ	73094LZ	73095LZ
480	410	525	435	563.41	177	562.77	221	73099LZ	73100LZ	73101LZ
500	420	550	450	592.06	186	593.33	233	73105LZ	73106LZ	73107LZ
520	440	570	470	611.15	192	611.15	240	73111LZ	73112LZ	73113LZ
540	460	590	490	633.44	199	631.53	248	73117LZ	73118LZ	73119LZ
560	480	610	510	652.54	205	651.90	256	73123LZ	73124LZ	73125LZ
580	500	630	530	671.63	211	672.27	264	73129LZ	73130LZ	73131LZ
600	520	650	550	693.92	218	692.64	272	73135LZ	73136LZ	73137LZ
620	530	670	570	728.93	229	728.29	286	66141LZ	66142LZ	66143LZ
640	550	690	590	748.03	235	748.66	294	66144LZ	66145LZ	66146LZ
660	570	710	610	767.13	241	766.49	301	66147LZ	66148LZ	66149LZ
680	590	730	630	789.41	248	789.41	310	66150LZ	66151LZ	66152LZ
700	610	750	650	808.51	254	807.23	317	66153LZ	66154LZ	66155LZ
720	630	770	670	827.61	260	827.61	325	66156LZ	66157LZ	66158LZ
740	650	790	690	846.70	266	845.43	332	66159LZ	66160LZ	66161LZ
760	670	810	710	868.99	273	868.35	341	66162LZ	66163LZ	66164LZ
780	690	830	730	888.08	279	886.17	348	66165LZ	66166LZ	66167LZ
800	700	865	735	919.92	289	919.28	361	66168LZ	66169LZ	66170LZ
820	720	885	755	939.01	295	939.65	369	66171LZ	66172LZ	66173LZ
840	740	905	775	958.11	301	957.48	376	66174LZ	66175LZ	66176LZ
860	760	925	795	980.39	308	980.39	385	66177LZ	66178LZ	66179LZ
880	780	945	815	999.49	314	998.22	392	66180LZ	66181LZ	66182LZ
900	800	965	835	1018.59	320	1018.59	400	66183LZ	66184LZ	66185LZ
960	860	1025	895	1079.07	339	1079.71	424	66192LZ	66193LZ	66194LZ
1000	900	1065	935	1120.45	352	1120.45	440	66198LZ	66199LZ	66200LZ
1100	1000	1165	1035	1219.13	383	1217.22	478	66386LZ	66387LZ	66388LZ
1200	1100	1265	1135	1320.99	415	1319.08	518	66389LZ	66390LZ	66391LZ
1300	1200	1365	1235	1419.66	446	1418.39	557	66392LZ	66393LZ	66394LZ
1400	1300	1465	1335	1518.34	477	1517.70	596	66395LZ	66396LZ	66397LZ
1500	1400	1565	1435	1620.20	509	1619.56	636	66398LZ	66399LZ	66400LZ

Load ratings as for type LDL aluminium design (page 43).  
Other diameters and in-between sizes available on request.

# Bearing Assemblies

Type LDV

Steel version  
Preference series



## Materials

Inner / Outer ring	Race ring	Balls	Cage	Seals
C45N	54SiCr6	100Cr6	PA12	NBR

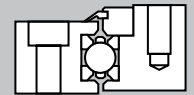

Gear: DIN 3967, quality 8e25, basic profile DIN 867

available from stock

## LDV

Ø KK mm	Load ratings KN				Dimensions mm														Weight kg	Order no.
	Coa	Cor	Ca	Cr	D	d	d1	d2	d3	d4	h1	h2	per ring	k1	s	SD	t1			
100	54	25	18	16	11	6.6	150 <sub>-0.10</sub>	50	135	65	30 <sup>±0.3</sup>	24	6 x 6.8	12.5	M 6	10	2.5	69715A		
200	110	52	24	21	11	6.6	250 <sub>-0.10</sub>	150	235	165	30 <sup>±0.3</sup>	24	8 x 6.8	12.5	M 6	10	5.0	66276A		
300	166	78	28	24	15	9.0	360 <sub>-0.10</sub>	240	340	260	38 <sup>±0.4</sup>	31	12 x 9.0	15.5	M 8	15	11.6	66277A		
400	429	202	48	41	18	11.0	470 <sub>-0.15</sub>	330	445	355	44 <sup>±0.5</sup>	37	14 x 11.0	16.0	M10	15	21.6	66278A		
500	541	255	52	45	20	14.0	580 <sub>-0.15</sub>	420	550	450	49 <sup>±0.5</sup>	42	14 x 13.0	19.5	M12	20	35.0	66865A		
600	654	308	56	49	20	14.0	680 <sub>-0.15</sub>	520	650	550	49 <sup>±0.5</sup>	42	16 x 13.0	19.5	M12	20	42.0	66866A		

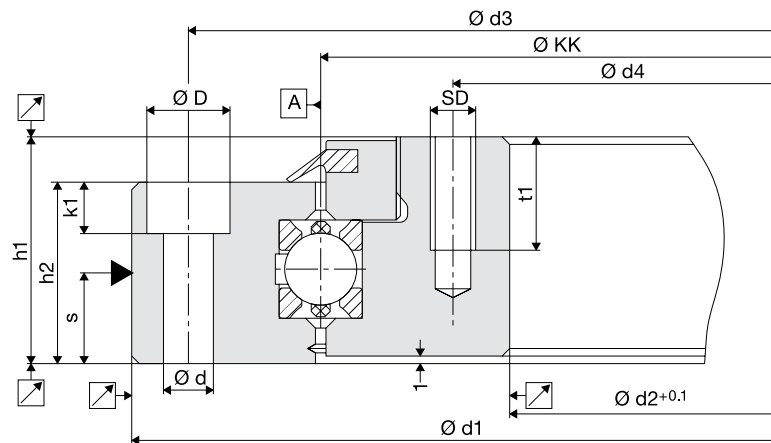

## LDV outer gear

Ø KK mm	Module m	Dimensions mm														Teeth number Z	Permit. peripheral forces KN		Order no. Bore shape C
		D	d	d01	d1	d2	d3	d4	h1	h2	b	per ring	k1	SD	t1		normal	max	
200	2	11	6.6	260	250 <sub>-0.10</sub>	150	235	165	35 <sup>±0.3</sup>	29	24	8 x 6.8	M 6	10	130	3.04	6.08	66276V	
300	3	15	9.0	372	360 <sub>-0.10</sub>	240	340	260	43 <sup>±0.4</sup>	36	31	12 x 9.0	M 8	15	124	6.24	12.48	66277V	
400	3	18	11.0	483	470 <sub>-0.15</sub>	330	445	355	49 <sup>±0.5</sup>	42	37	14 x 11.0	M10	15	161	7.68	15.36	66278V	

Order numbers of bore shape A and B on request.

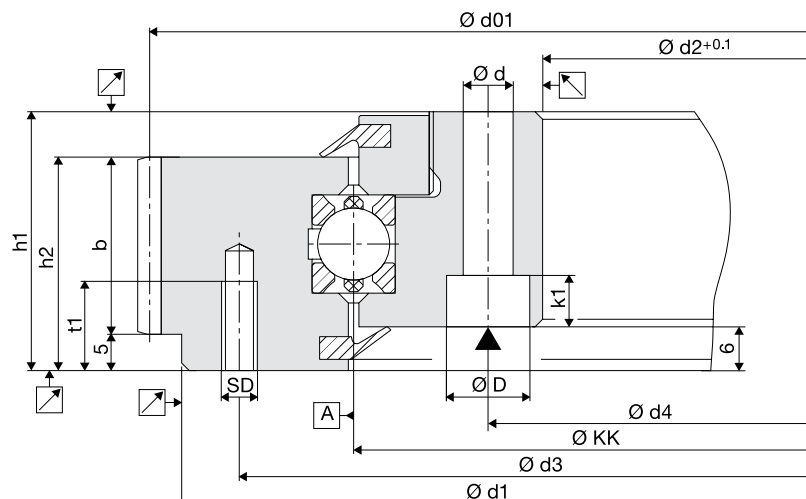

**Materials**

**Type LDH**

Steel version  
Angular ball bearings

Inner / Outer ring	Race ring	Balls	Cage
C45N	54SiCr6	100Cr6	PA12

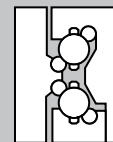

**LDH**

Ø KK inch	Ø KK mm	Load ratings KN				Diameter				Height		Weight kg	Order no.
		Coa	Cor	Ca	Cr	inch d1	mm d1	inch d2	mm d2	inch h1	mm h1		
21	533.4	712	335	66	57	22	558.8	20	508	2	50.8	11.5	66602A
26	660.4	878	413	71	61	27	685.8	25	635	2	50.8	14.0	66603A
31	787.4	1050	494	75	65	32	812.8	30	762	2	50.8	16.5	66604A
36	914.4	1222	575	80	69	37	939.8	35	889	2	50.8	19.0	66605A
41	1041.4	1394	656	84	73	42	1066.8	40	1016	2	50.8	21.5	66606A

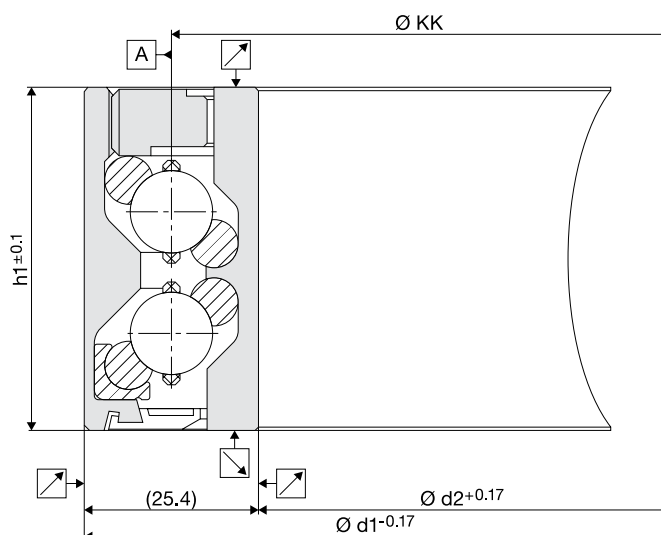

# Rotary Tables

Type LTA

Standard

## Materials

Base plate	Raceways	Balls	Worm wheel	Worm shaft	Housing
Aluminium	High-alloy spring steel	Antifriction bearing steel	Wear-resistant bronze alloy	CK45N hardened and ground	V2A

## LTA

Nominal Ø mm A	Load ratings KN		Tilt moment Nm Com	Input rotary speed U/min N <sub>1max</sub>	Gear reduction i	Output rotary speed U/min N <sub>2max</sub>	Input torque Nm M <sub>1max</sub>	Output torque Nm M <sub>2max</sub>	Weight kg	Order no.
	Co	C								
100	17.5	9	289	1800	18	100	5	54	5.5	91800A
200	43.0	18	433	2200	36	61	5	108	10.0	91801A

Nominal Ø																						
A	B	ØE <sup>H7/6 deep</sup>	ØF	ØG	ØG <sub>1</sub> <sup>H7/12 deep</sup>	H	I	K	L <sub>1</sub>	L <sub>2</sub>	M	N	O	P	Q	R	S	T	U	V	W	X
100	85	70	45	30	30	155	125	65	62.5	91.5	70	96.0	65.0	61	99.5	69.5	17	2	4xØ6.6	39	17	4xM6
200	175	160	130	110	110	255	220	70	110.0	139.0	165	145.5	114.5	63	147.0	117.0	22	7	6xØ9.0	39	22	6xM8

	Ø	100	200
Axial and radial accuracy	µm	30	30
Positioning accuracy in angular seconds	sec	160	120
Repeat accuracy in angular seconds	sec	20	14

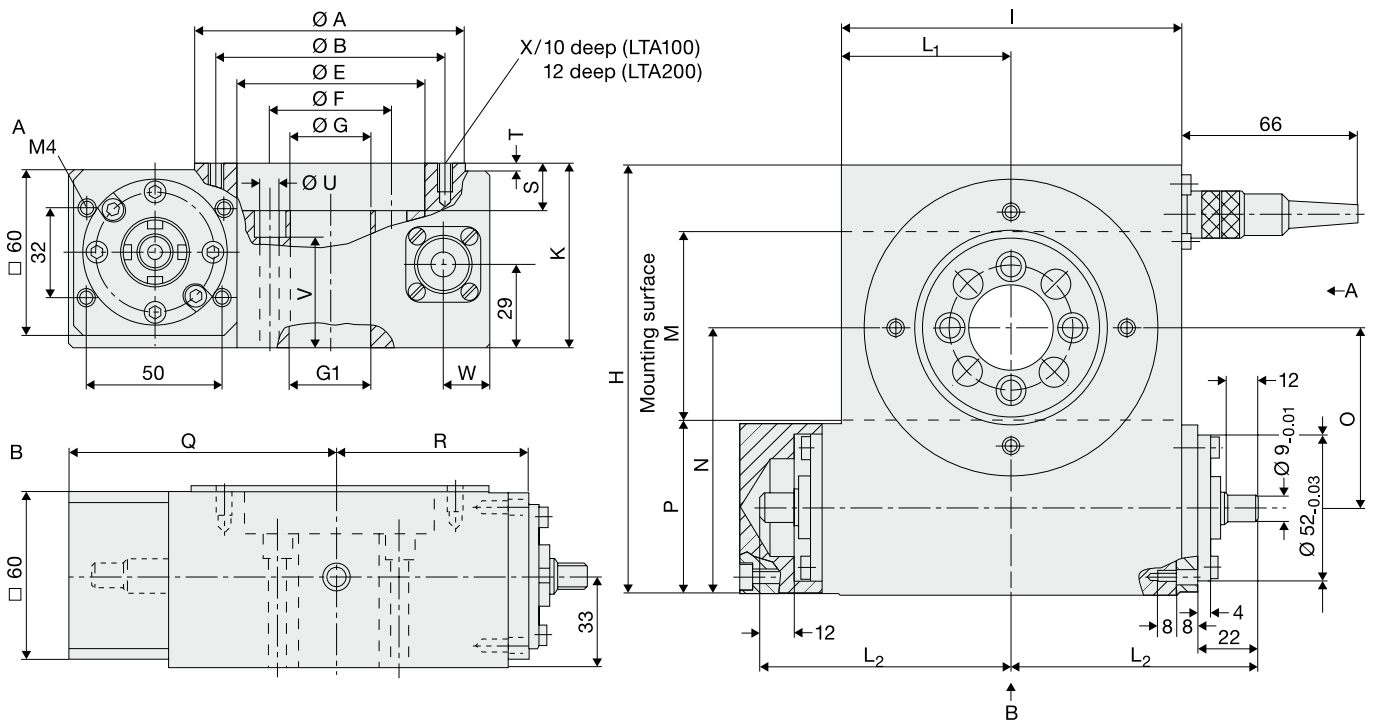

# Type LTB

High accuracy

## Materials

Body material	Raceways	Balls	Worm gear
Aluminium ribbed	High-alloy spring steel	Antifriction bearing steel	Steel-bronze alloy

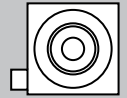

Vacuum and part-magnetic design possible

## LTB

Nominal Ø	Load ratings	Tilt moment	Input rotary speed	Gear reduction	Output rotary speed	Input torque	Output torque	Weight	Order no.
mm	N	Nm	U/min	i	U/min	Nm	Nm	kg	
A	Co	Com	N <sub>1max</sub>		N <sub>2max</sub>	M <sub>1max</sub>	M <sub>2max</sub>		
125	1950	110	2500	360	7	0.7	70	3	91042A
175	2550	140	2500	360	7	0.9	75	6	91043A
265	4200	310	2500	360	7	1.5	160	10	91044A
400	14100	1780	2500	360	7	2.0	290	27	91045A

Nominal Ø		A	B	C <sup>96</sup>	D <sup>H7</sup>	E	F <sup>H7</sup>	G	H	K	L	M	N	O	P	Q	R	S	T	U1	U2	V <sub>1</sub> <sup>96</sup>	V <sub>2</sub> <sup>96</sup>	V <sub>3</sub> <sup>96</sup>	V <sub>4</sub> <sup>96</sup>	W
125	100	-	70	70	100	150	165	75	-	10	4x M5	4x 7.0	5	34	5	112	60	67.5	67.5	6	22	6	22	135		
175	126	-	102	70	102	178	-	82	-	12	6x M6	3x 6.6	4	31	4	152	63	98.0	98.0	6	52	6	52	196		
265	200	150	-	105	150	230	250	90	4	16	6x M10	4x 10.0	-	43	5	171	81	95.0	98.0	8	38	6	38	193		
400	340	300	200	190	270	380	400	100	4	16	6x M10	6x 11.0	5	43	5	229	139	124.0	127.0	8	38	6	38	251		

Nominal Ø	X1	X2	X3	Y1	Y2	Z	Ø 125	175	265	400		
125	21.8	26	2xM4/16 deep	8	9	2.8	Axial and radial accuracy	µm	20	20	20	30
175	50.0	32	4xM4/13 deep	18	18	4.0	Positioning accuracy in angular seconds	sec	80	80	70	50
265	45.0	26	4xM5/24 deep	10	7	2.5	Repeat accuracy in angular seconds	sec	16	14	10	8
400	45.0	26	4xM5/24 deep	9	6	2.5						

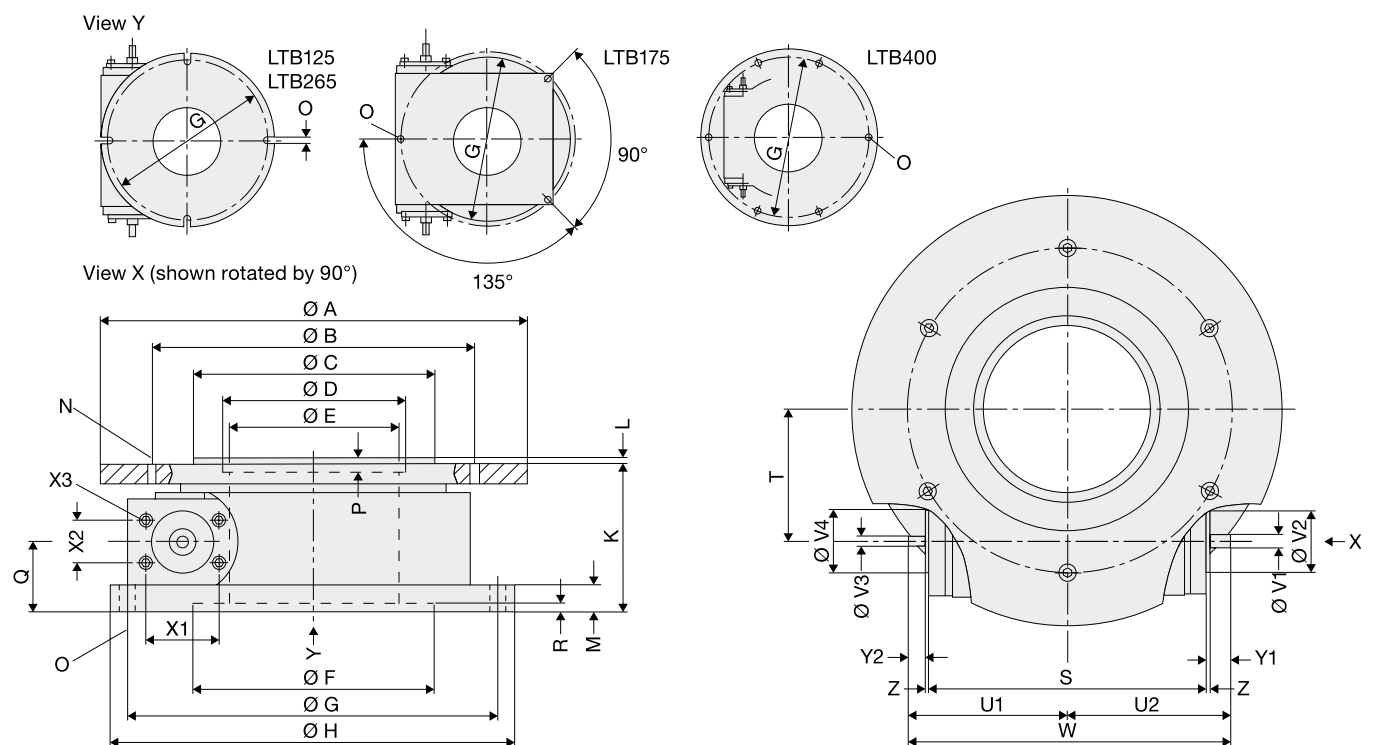

## Standard Cages

### Strip cages of the LKB type

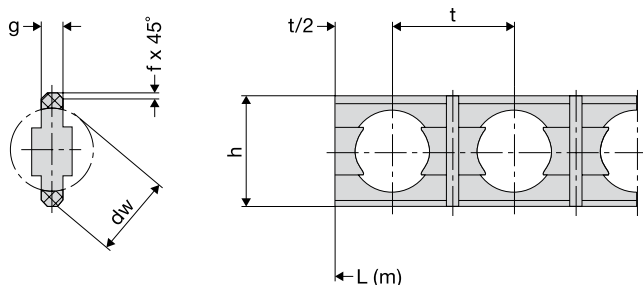

Cage size	d <sub>w</sub>		Dimensions				Order no. (bulk stock)
	mm	inch	h	g	t	f	
LKB5	5.0	3/16	7.6	1.5	7.5	0.4	78916A
LKB6	6.0		8.6	1.6	9.2	0.4	78917A
LKB8	8.0	5/16	10.6	2.0	12.0	0.6	78918A
LKB9.5	9.5	3/8	12.6	2.5	14.0	0.7	78920A
LKB10	10.0		13.2	2.5	14.0	0.7	78921A
LKB11	11.0		13.2	2.5	14.0	0.7	78922A
LKB12	12.0		15.0	2.5	16.0	0.7	78923A
LKB15	15.0		18.6	3.0	18.6	0.7	78924A
LKB16	16.0		19.6	3.0	20.0	0.7	78925A
LKB20	20.0	25/32	24.2	3.5	26.0	0.7	78926A

Material: PA12

The strip cage is segmented into the required lengths and supplied ready for use with balls. The number of required balls is calculated by:

$$Z = \left[ \frac{\varnothing KK \cdot \pi}{t} \right] - 1$$

$Z$  = number of balls  
 $\varnothing KK$  = ball pitch diameter  
 $t$  = ball distribution (tolerance  $\pm 0.2$ )

The number of segments depends on the bearing diameter and the ball size. Guide values:

$\varnothing KK$ mm	< 200	200-399	400-799	800-1500
Number of segments	3-4	4-6	6-8	8-12

The strip cage can also be ordered as a one-piece for special applications.

## Special Cages

### Flat cages of laminated cloth, non-corrosive, brass

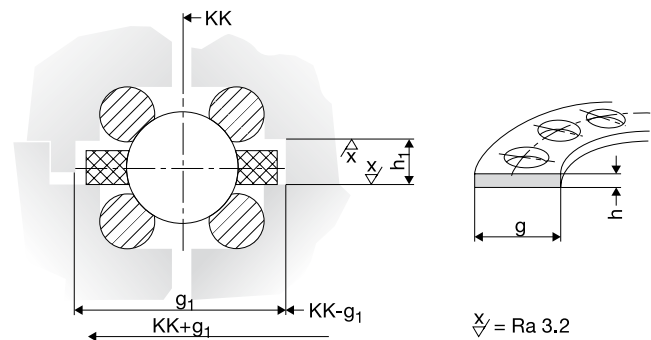

d <sub>w</sub> mm	h x g mm	h <sub>1</sub> x g <sub>1</sub> mm	Order no.
5.0	2 x 10	2.7 x 13	on request
6.0	2 x 12	2.7 x 15	
8.0	3 x 15	4.0 x 18	
9.0	3 x 16	4.0 x 18	
9.525	3 x 18	4.0 x 20	
12.0	4 x 20	5.5 x 23	
16.0	5 x 26	6.5 x 30	
20.0	6 x 31	7.5 x 35	
25.0	8 x 38	10.0 x 43	
30.0	8 x 45	10.0 x 50	
40.0	12 x 56	14.0 x 61	
50.0	15 x 80	17.5 x 88	

Material: laminated cloth, brass, non-corrosive

### Strip cages of laminated cloth, non-corrosive, brass

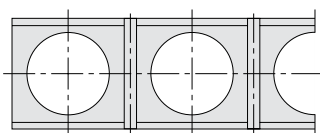

Use of a flat cage is mandatory at temperatures over 100 °C and for ball diameters greater than 20 mm. Special solutions, such as complete corrosion protection or radiation adjustment, are also available.

### Comb cages

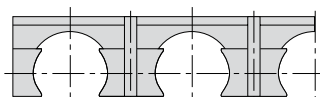

Special cages in the form of strip or comb cages are available for special applications with regard to environmental influences or mounting space requirements.

Franke offers materials like plastic, non-corrosive steel, brass, Teflon etc.

## Washers

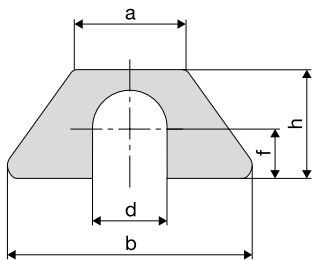

Adjustment between the divided inner or outer rings is simplified by washers for larger bearings or bearing elements. The washers are made of non-corrosive sheet steel. A theoretical begin column of 0.5 mm is recommended in the construction design for adjustment.

Size	Dimensions mm				
	a	b	d	f	h
M 6	11.0	24.4	7	5	11.0
M 8	14.7	34.2	9	6	13.5
M10	16.4	42.3	11	7	16.0
M12	20.3	46.0	13	8	18.0
M16	25.4	54.0	17	11	24.0

Gauge mm	Order no.							
	0.025	0.1	0.15	0.2	0.25	0.3	0.5	1.0
M 6	79015A	79034A	79035A	79036A	79037A	79038A	79039A	79040A
M 8	79041A	79023A	79042A	79000A	79026A	79043A	79044A	79045A
M10	79046A	79012A	79010A	79011A	79047A	79048A	79049A	79050A
M12	79118A	79051A	79052A	79053A	79054A	79055A	79056A	79065A
M16	79119A	79024A	79066A	79057A	79058A	79059A	79060A	79061A

## Seals

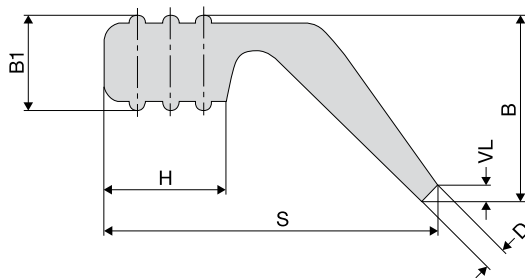

The bearing assemblies are equipped with the S10 collar seal as standard. Temperature:  $-30\text{ }^{\circ}\text{C}$  to  $+80\text{ }^{\circ}\text{C}$  (NBR). Max. peripheral speed: 5 m/s.

For sealing the construction (e.g. for use as a bearing element) seals can be ordered as bulk stock. The point of impact is then glued with the adhesive Loctite 401®.

Profile	Dimensions mm				Material	Preload mm	Weight kg/m	Order no.
S	H	$B^{\pm 0.3}$	$B1^{\pm 0.2}$	D		VL <sup>1</sup>		
10	4.2	5.3	3.0	0.8	Perbunan 70NBR/221	0.5...1.5	0.026	09080
10	4.2	5.3	3.0	0.8	Viton	0.5...1.5	0.026	46062
15	5.5	8.5	4.3	1.0	Perbunan 70NBR/221	0.5...2.0	0.051	09190

<sup>1</sup> depending on bearing assembly (approx. 1 Nm/m seal)

## Installation Dimensions

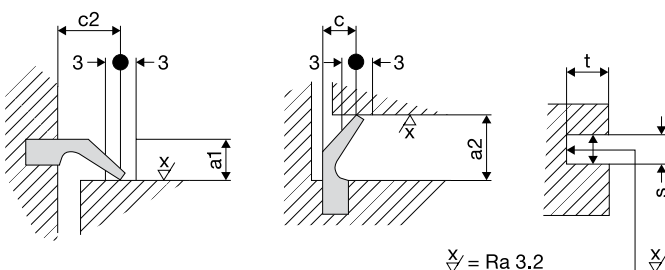

Profile	Installation dimensions mm				Groove dimension mm	
	c	c2	a1	a2	$t^{\pm 0.2}$	$s^{\pm 0.1}$
10	5+1	5.5+1	3.6...4.6	4.3...5.3	4.2	2.8
15	8+1.5	9.0+1.5	6.3...7.7	7.5...9.0	5.5	3.9

Important note: measure seal first, then make groove.

Special seals are available on request. Franke offers Viton seals for high temperatures or aggressive media.

## 1 Choice of Antifriction Bearings

It is best to select and size the bearing before design begins.

### 1.1 Parameters for Choosing Bearings

- Permitted dimensions and material information of the bearing.
- Loads with load spectrums and associated time slices in %.
- Rotary speed and number of rotating motions and rotating angle per time unit.
- Peripheral forces to be borne by the gear.
- Other operating conditions, such as temperature, vacuum, clean room, moisture ...

An approximate choice of bearing is possible using the catalogue. All relevant data are to be found on the pages for the individual types.

### 1.2 Static and Dynamic Load Capacity, Calculation

The figures given in the catalogue for the static and dynamic load ratings are for a preliminary design, but are insufficient for exact sizing. The load ratings given correspond to the radial load ratings. Exact sizing requires the static axial, radial and torque load ratings and the dynamic axial and radial load ratings. The axial values are approximately higher by a factor of 2. Franke will perform the calculation on request.

## 2 Installation and Set-Up of Bearing Elements

Bearing elements consist of two inner and two outer race rings and a multipart, segmented cage with balls. The race rings are divided and can, thus, be used flexibly in the diameter for installation.

The balls correspond to quality grade 3 (DIN 5401). Only the supplied balls may be used. If balls are lost, all the balls must be exchanged to ensure the race characteristics of the bearing are not impaired.

Setting the preload is an important requirement for a long lifetime. This guarantees that all raceways are sharing the load and the balls are running perfectly in the predetermined positions.

### 2.1 Setting with Washers

Setting using washers is the most cost-effective and flexible method, as this still allows readjustment of the adjustment later

on. You can order the washers by screw diameter in different thicknesses (see accessories p. 55).

Requirements:

- Spacing of the inner or outer design.
- The height of the race ring bed is 0.3 to 0.5 mm smaller on the side of the divided mating structure. This gap is needed to insert the washers.
- The divided side of the mating structure should be fixed with a centering collar. This is the only way to guarantee the parallelism.

Installation and set-up:

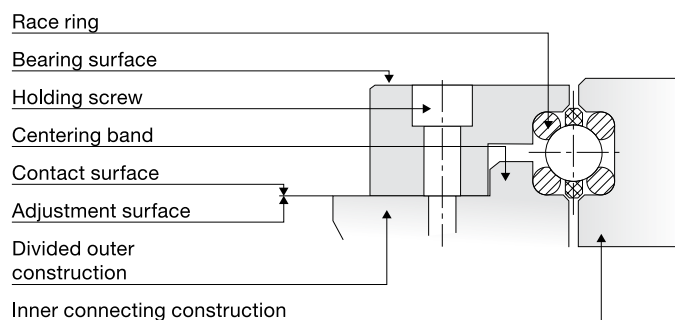

The race rings are laid in the mating structure. The race ring beds can be greased to hold the race rings in position during installation. The points of impact of the opposite race rings in the same section, are installed at an angle of approx. 180°. Afterwards, the divided side of the mating structure is brought to the intended position.\* Then, you insert the cage segments with the balls and grease the bearing element (see 4.1 Lubrication). Before the mating structure of the divided side is closed, arrange the washers on the screw borings of the holding screws. The thickness depends on the in-built gap (see above). Once the screws are tightened (see 4.5 Screws) and the bearing assemblies have been turned about 2 to 3 times through 360°, check the adjustment. If the values differ by more than 5 to 10 %, the thickness of all washers must be changed and the process repeated.

\*Applies for both installation methods 2.1 and 2.2

### 2.2 Setting through Massive Adjustment

When setting using massive adjustment, the adjustment surface is brought to the correct level by subsequent grinding. The best accuracy is achieved with this method, as the joint face



between the divided side of the mating structure is form-fit and no tension bridges can build up.

Requirement:

- Spacing of the inner or outer design.
- Surface grinding machine of suitable size.
- The height of the race ring bed is 0.1 mm larger on the side of the divided mating structure. This oversize is necessary for the adjustment.
- The divided side of the mating structure should be fixed with a centering collar. This determines the parallelism of the two raceways.

Installation and set-up:

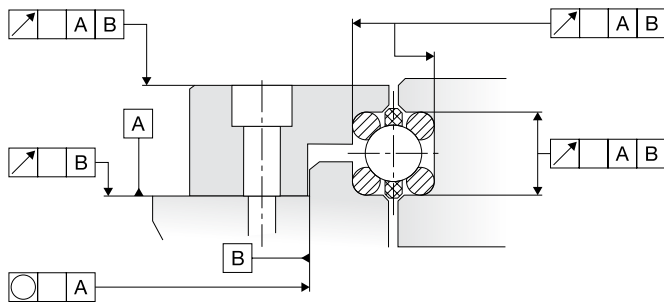

Then insert the cage segments with the balls and close the bearing assembly with the two divided sides of the mating structure (adjustment ring). Once the screws have been tightened properly (see 4.5 Screws) and the bearing assembly has been turned 2 to 3 times through 360°, measure the space between the inner and outer ring using a test gauge. Then the adjustment ring is taken off again and the determined value plus 0.02 to 0.03 mm is ground off with the grinding machine.

To ensure the parallelism is maintained between this surface and the raceway, a suitable bearing surface should already be chosen during design.

After thorough removal of the ground dust, the ring is refitted as described and the bearing moves. Then check the adjustment. If this value differs by more than 5 to 10 %, the procedure must be repeated. Finally, the bearing assembly is greased via the in-built grease borings (see 4.1 Lubrication).

Note:

Setting the preload is advisable, as there are tolerances that need to be compensated even with the best production.

### 3 Installation and Set-Up of Slim Bearings

Slim bearings of the LDD type are highly loadable, pre-finished bearing elements, which can be fitted very easily in a small installation space. With slim bearings the bearing element (four ball race rings with ground raceway and a plastic band cage with retained balls) is embedded in a steel inner and outer casing. The casings are peripherally divided and form a pre-finished bearing, which is integrated directly in each design.

In contrast to standard, closed and ground slim bearings, the play on Franke slim bearings is not dependent on the fit of the outer and inner rings. As a result, fitting and removing are easier and require no special tools or thermal treatment.

The bearings are suitable for permanent operation at temperatures between  $-10\text{ °C}$  and  $+70\text{ °C}$  – and briefly for use up to  $+120\text{ °C}$ . Peripheral speeds of 10 m/s with fat lubrication and 12 m/s with oil lubrication can be achieved.

Setting the preload is an important requirement for a long lifetime of the slim bearing. This guarantees that all raceways are sharing the load and the balls are running perfectly in their predetermined positions. The preload is set correctly when the adjustment corresponds to the values in the diagram at point 6 without seal.

Note:

Setting the preload is advisable, as there are tolerances that need to be compensated even with the best production.

#### 3.1 Settings with Washers

Setting using washers is the most cost-effective and flexible method, as this still allows readjustment of the adjustment later on. You can order the washers by screw diameter in different thicknesses (see accessories p. 55).

Requirements:

- Spacing of the inner or outer design.
- The height of the race ring bed is 0.3 to 0.5 mm smaller on the side of the divided mating structure. This gap is needed to insert the washers.
- The divided side of the mating structure can be fixed with a centering collar to improve the parallelism of the raceways.

## Installation suggestion A:

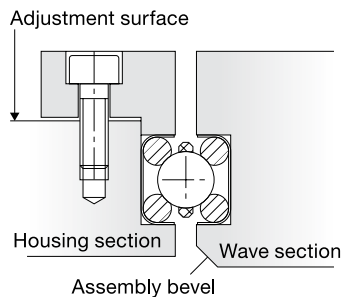

The slim bearing is laid in the mating structure. Before the mating structure of the divided side is closed, arrange the washers on the screw borings of the holding screws. The thickness depends on the in-built gap (see above). Once the screws are tightened (see 4.5 Screws) and the bearing assemblies have been turned about 2 to 3 times through 360°, check the adjustment. If the values differ by more than 5 to 10 %, the thickness of all washers must be changed and the process repeated.

### 3.2 Setting through Massive Adjustment

When setting using massive adjustment, the adjustment surface is brought to the correct level by subsequent grinding. The best accuracy is achieved with this method, as the joint face between the divided side of the mating structure is form-fit and no tension bridges can build up.

#### Requirement:

- Spacing of the inner or outer design.
- Surface grinding machine of suitable size.
- The height of the wire ring bed is 0.1 mm larger on the side of the divided mating structure. This oversize is necessary for the adjustment.
- The divided side of the mating structure can be fixed with a centering collar. In this way the parallelism of the two raceways is improved.

#### Installation and set-up:

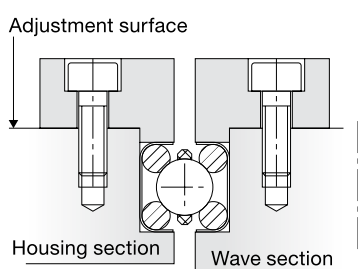

The slim bearing is inserted into the mating structure and the bearing is closed with the two divided sides of the mating structure (adjustment ring). Once the screws have been tightened properly (see 4.5 Screws) and the bearing has been turned 2 to 3 times through 360°, measure the space between the inner and outer ring using a test gauge.

Then the adjustment ring is taken off again and the determined value plus 0.02 to 0.03 mm is ground off with the grinding machine. To ensure the parallelism is maintained between this surface and the raceway, a suitable bearing surface should already be chosen during design. After thorough removal of the ground dust, the ring is refitted as described and the bearing moves. Then check the adjustment. If this value differs by more than 5 to 10 %, the procedure must be repeated.

## 4 Installation and Set-Up of Bearing Assemblies

Franke bearing assemblies are pre-finished complete bearings – regardless of whether they are standard bearings from the catalogue or a customer-specific version. The preset or defined race accuracy, adjustment, stiffness and general characteristics are dependent on the mating structure and on the accuracy or completeness of the data supplied. Therefore, particular attention must be paid.

### 4.1 Lubrication and Maintenance

To keep friction low and to protect the bearing from corrosion in the long run, ensure use of sufficient lubrication. All lubricants undergo an ageing process, which limits the service life. The best ageing stability is achieved with fully synthetic lubricants. ISOFLEX TOPAS NCA52 (special grease from Klüber, designation in accordance with DIN 51502: KHC2 N-50) is used as the initial lubrication on Franke bearings. The ageing stability of this lubricant is for approx. three years. This lubricant is also recommended for the use of bearing elements.

High quality lithium soap fats based on polyalpha-olefin or mineral oils and in accordance with DIN 51825-K2 K-40 are suitable as an alternative. Questions on lubricants, such as miscibility, aggressiveness, extreme temperatures, removal, areas of use etc., must be clarified with the relevant lubricant manufacturer.

### 4.2 First or Relubrication

The amount of lubricant that an Antifriction Bearing needs for lubrication is relatively low and is dependent on the rotary speed. Because of the flexing work, too much lubricant causes increased temperatures, which limit or prevent lubricity. The

bearing's lifetime is substantially reduced due to the increased wear. The amount of lubricant is determined by the calculated play inside the bearing assembly. The calculated volume must be filled with 20 to 30 % lubricant. The recommendation is 30 to 40 % for slewing bearings.

### 4.3 Relubrication and Lubrication Periods

The lubricity reduces due to mechanical loads and ageing. Therefore, it is necessary to supplement or completely replace the existing lubricant (e.g. in the event of heavy soiling). The bearing must be rotated during relubrication. Relubrication should be effected at operating temperatures as far as possible.

The amounts for relubrication are calculated as follows:

- $m$  =  $\varnothing$  KK x  $h^2/3$  x X
- $h^2$  = bearing ring height in mm
- $\varnothing$  KK = ball pitch diameter in mm
- $m$  = amount of lubricant in g
- X = factor according to table 1 in  $mm^{-1}$

Relubrication periods:

Exact determination of the periods is usage-specific and, therefore, can only be correctly determined by trial and error (guide values see table 1). To determine the X factor (table 2), use the read time value in reference to the operating time of the application.

Note: for standard bearings applying one lubrication application is sufficient, as the lubricant is evenly distributed by the bearing rotation. For slewing bearings at least three relubrication applications are needed ( $3 \times 120^\circ$ ).

Vu m/s	Frequency h
0 to < 3	5000
3 to < 5	1000
5 to < 8	600
3 to < 10	200

Table 1: Relubrication Periods

Frequency	weekly	monthly	yearly	2-3 years
X	0.002	0.003	0.004	0.005

Table 2: Relubrication Intervals

Circular oil lubrication is possible in principle and should be discussed with the relevant lubricant manufacturer. Lubricant-free bearings are available for special applications (e.g. clean room or ultrahigh vacuum).

Calculation example:

bearing assembly of type LDL,  $\varnothing$  KK 500 mm, order no. 73105Y  
Peripheral speed 3 m/s  
Operating time approx. 16 hrs/day

Relubrication period for 3 m/s is 1000 hrs (see table 1)  
= 1000 (hrs) / 16 (hrs/day) = 63 days ~ 3 months for 16 hrs/day operating time

Relubrication should be effected quarterly. The X factor (table 2) is rounded off and is 0.003. The  $h^2$  measurement is 42 mm (see catalogue page 40).

$$m = 500 \text{ mm} \times 42/3 \text{ mm}^{-1} \times 0.003 \text{ g} = 21 \text{ g}$$

Thus, relubrication of 21 g of ISOFLEX TOPAS NCA52 should be applied every three months. The lubricant has a shelf life of three years.

### 4.4 Lubrication and Lubrication Periods for the Gear

Automatic gear lubrication is recommended. With manual lubrication, the gear and the pinion must be sufficiently lubricated before start-up. The lubrication period depends on the design and peripheral speed and, therefore, must be determined individually.

### 4.5 Screws

The number of screws and the diameter for fixing to the mating structure should be checked in principle. The spacing X from holding screw to holding screw should not exceed 125 mm to avoid formation of bridges. The fixing screws are tightened crosswise with a torque wrench in relation to the screw quality – according to the figures in table 3.

	Quality	
	Nm 8,8	Nm 12,9
M6	10	17
M8	25	41
M10	49	83
M12	86	145
M16	210	355

Table 3: Starting Torque

The screws need to be retightened with the prescribed tightening moment to resolve settling phenomena. This process should be effected as far as possible when the screws are free of additional forces. They must be checked after around

100 and then every 600 operating hours. This period can also be much shorter for special applications (e.g. heavy vibrations).

## 4.6 Gear

Franke supplies straight gear without hardening as standard (material 42CrMo4V) and special gears on request. The material, design and quality can be changed at any time on request.

The catalogue figures with regard to permitted peripheral forces were determined using the permitted bending stress in the tooth foot. The maximum forces relate to extreme loads, which occur in the event of brief impact loads such as starting and braking. These values are for guidance purposes only and can only be determined through a gear calculation, including both components pinion and bearing assembly.

## 4.7 Tolerance and Accuracy

All tolerances and accuracies are given on the relevant page of the catalogue. The greatest possible accuracy is achieved when the constructive design of the encapsulating parts is effected in such a way that machining of all related diameters and surfaces can be performed in a clamp.

The run accuracy values in the catalogue are maximum values and can be improved further by limiting the tolerances.

The tolerance values  $T = IT6$  or  $T = IT7$  relate to the diameter-dependent basic tolerances in accordance with DIN ISO 286 (see table 4).

Nominal size range mm over ... to	Basic tolerances	
	$\mu\text{m}$ IT6	$\mu\text{m}$ IT7
80... 120	22	35
120... 180	25	40
180... 250	29	46
250... 315	32	52
315... 400	36	57
400... 500	40	63
500... 630	44	70
630... 800	50	80
800... 1000	56	90
1000... 1250	66	105
1250... 1600	78	125

Table 4: Tolerances

DIN ISO 286 T1 (11.90)

## 5 Rotary Tables

Franke Rotary Tables have a high load capacity and are ideally suited for assembly, measuring and inspecting tasks. All Rotary Tables have a compact aluminium housing with integrated Franke components. A worm gear pair guarantees high accuracy also for permanent loading. The Rotary Tables are extremely tip-resistant with a low own weight. Precise technical details are on the relevant pages in the catalogue.

### 5.1 Load Capacity

The recommended safety for Franke Rotary Tables is  $SST \geq 3$  for simple loading and  $SST \geq 6$  for dynamically changing loading and lifting. Franke will perform calculations on loading and lifetime on request.

### 5.2 Temperature Range

The Rotary Tables can be used at an operating temperature of  $-10\text{ }^{\circ}\text{C}$  to  $+80\text{ }^{\circ}\text{C}$ . Expanded temperature ranges are possible on request.

### 5.3 Lubrication

In general, all standard Rotary Tables ex works have long-term lubrication with the Antifriction Bearing grease Isoflex Tops NCA52. It is recommended that Franke Rotary Tables – depending on usage – are relubricated twice a year to once a year (see also 4.1 Lubrication and maintenance).

Lubrication point	Relubrication amount per lubrication point
	g front side
LTA100	1
LTA200	1
LTB125	3
LTB175	3
LTB265	3
LTB400	1

### 5.4 Options

- One or two inductive proximity switches, integrated inside the table
- Freely positionable trips
- Adaptor sets for motors at customer's request
- Motorisation depending on application with step or servo motors
- Rotary encoder on the second shaft extension of the worm shaft
- Complete automation solutions

**Please follow assembly and maintenance instructions. They are included with every delivery.**

## 6 Adjustment Values and Accuracy

The adjustment gives information on the preload of the bearing assembly. It depends on the individual type and the rolling circle (see 6. Adjustments of individual types). However, these values are not definitive and, therefore, can be adjusted individually depending on the application.

The stiffness is indirectly related to the adjustment. The rule of thumb: the higher the adjustment, the higher the stiffness. The adjustment increase by the seal S10 (see Accessories page 55) amounts to approx. 1 Nm/m circumference and sealing side. This value can fluctuate depending on dry running or surface quality.

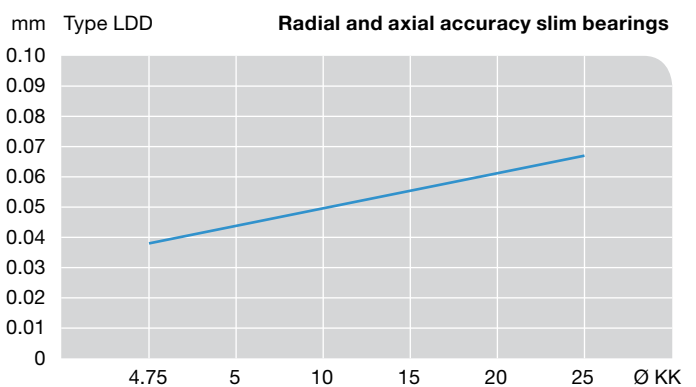
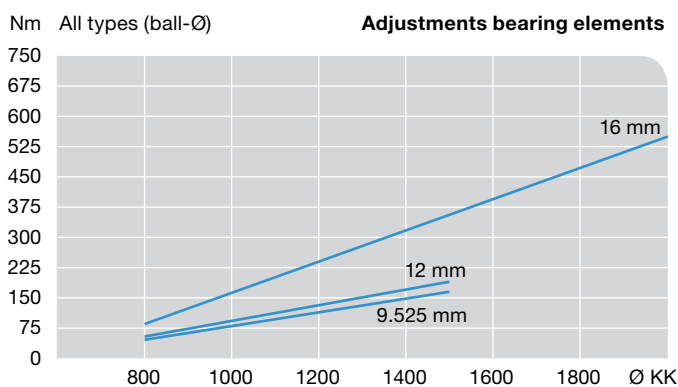
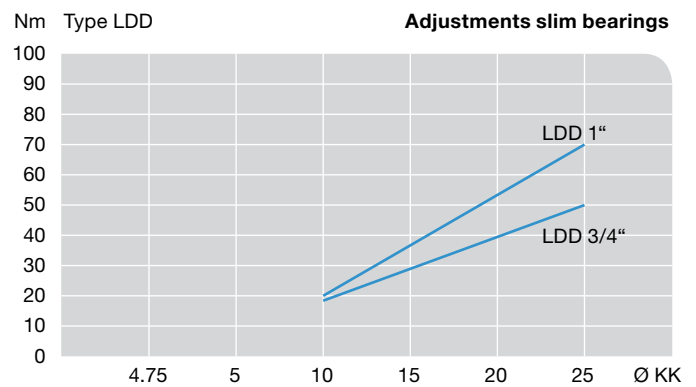
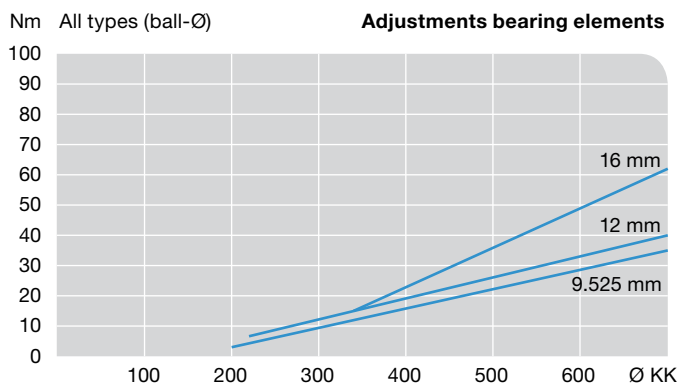
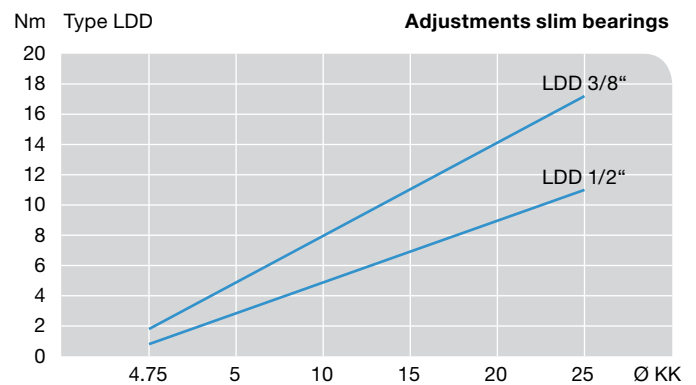
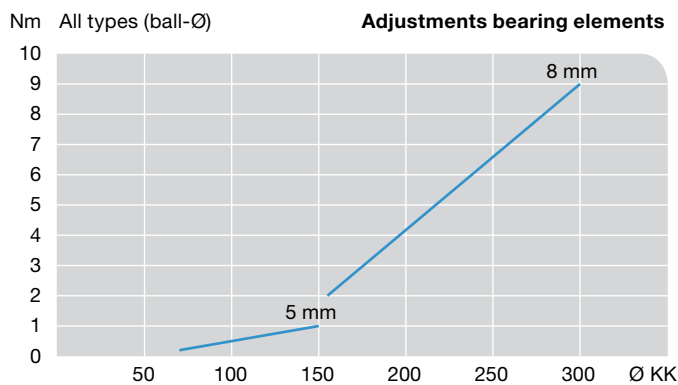
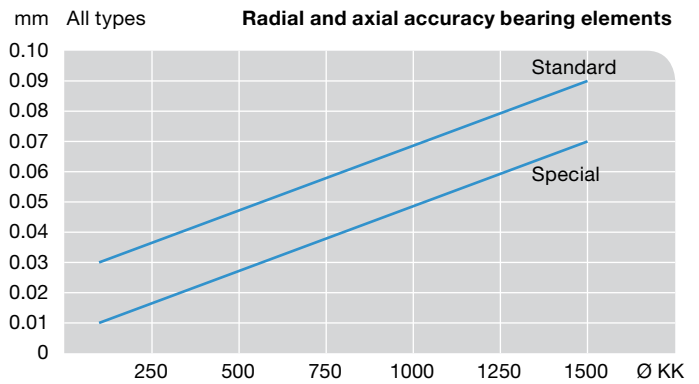

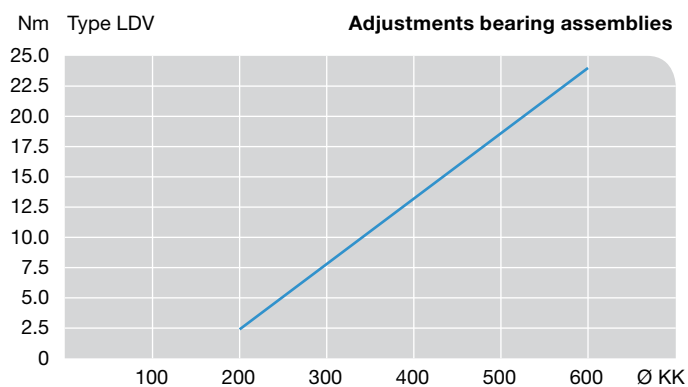
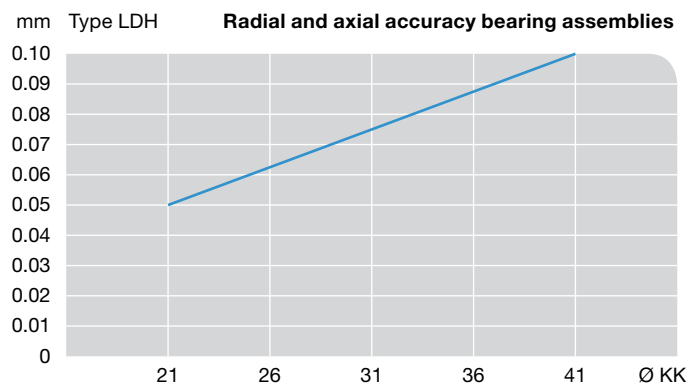
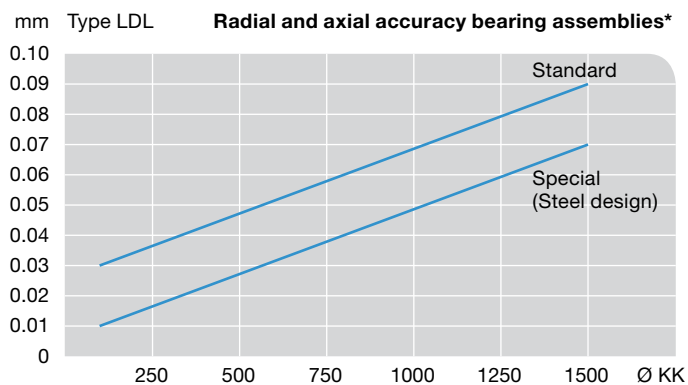
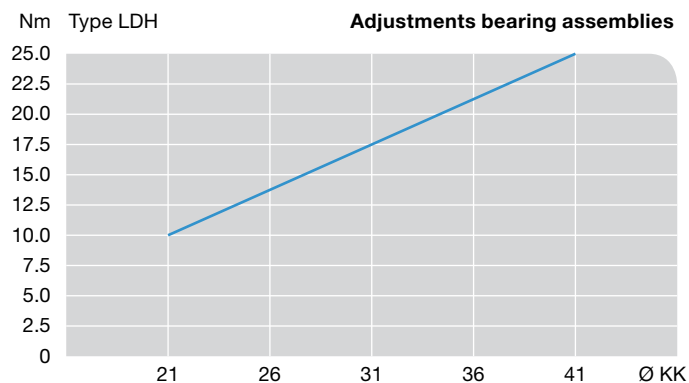
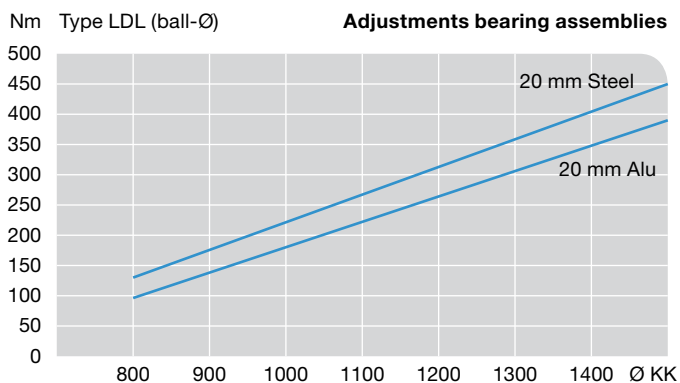
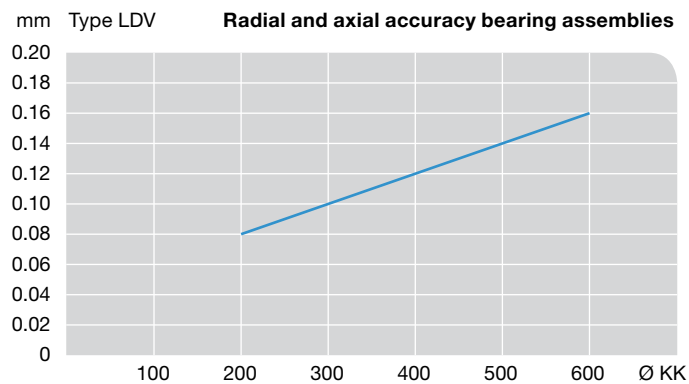
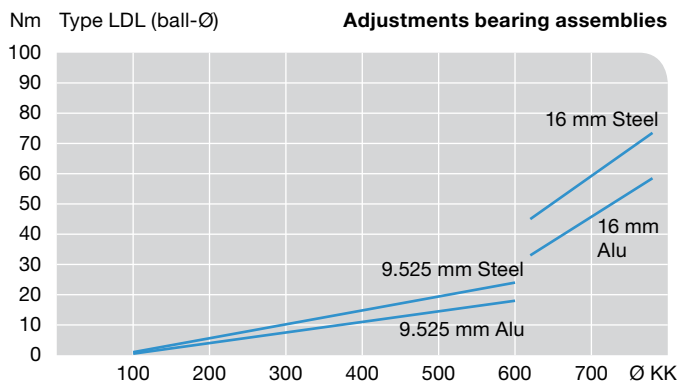

\*Concentric and axial run-outs are directly related to the profile and the material of the bearing.











# Linear Systems

Page

<b>Overview, Examples of Use, Advantages/Characteristics</b>			66 – 77	
<b>Franke Dynamic</b>				
Type FDA	Standard		78 – 79	
Type FDB	Low cost		80 – 81	
Type FDC	Non-corrosive		82 – 83	
Type FDD	Non-magnetic		84 – 85	
Type FDE	Lubricant-free		86 – 87	
Type FDG	Non-corrosive low cost		88 – 89	
Type FDH	High dynamic		90 – 91	
<b>Franke Power</b>				
Type FPA	Standard		92 – 93	
<b>Franke Robust</b>				
Type FRA	Standard		94 – 95	
<b>Linear Tables/Modules</b>				
FTB	Spindle Drive		96 – 97	
FTC	Spindle/Belt Drive		98 – 99	
FTD	Belt Drive		100 – 101	
FTH	Linear Motor Drive		102 – 105	
<b>Accessories</b>				
Guides			106 – 107	
Modules			108 – 109	
<b>Technical Information</b>				
Franke Dynamic			110 – 112	
Franke Power			113 – 114	
Franke Robust			115 – 116	
Linear Tables/Modules			117 – 119	

# Linear Systems at a Glance

Roller Guide Franke Dynamic					
Type	<b>FDA</b> Standard	<b>FDB</b> Low cost	<b>FDC</b> Non-corrosive	<b>FDD</b> Non-magnetic	<b>FDE</b> Lubricant-free
<b>Components</b>	<ul style="list-style-type: none"> <li>Steel raceways</li> <li>Needle bearing rollers</li> </ul>	<ul style="list-style-type: none"> <li>Steel raceways</li> <li>Ball bearing rollers</li> </ul>	<ul style="list-style-type: none"> <li>Non-corrosive raceways</li> <li>Needle bearing non-corrosive rollers</li> </ul>	<ul style="list-style-type: none"> <li>Non-magnetic raceways</li> <li>Needle bearing rollers</li> </ul>	<ul style="list-style-type: none"> <li>Steel raceways</li> <li>Lubricant-free rollers</li> </ul>
<b>Options</b>	<ul style="list-style-type: none"> <li>Aluminium body material for cassettes, roller shoes and guide raceways</li> <li>Plastic wiper with felt insert on both front sides of the cassettes or roller shoes</li> <li>Special guide profiles</li> <li>Surface coating of the raceways and cassettes</li> <li>Customer-specific connection borings</li> <li>Metal wipers</li> <li>Bellow covers</li> <li>Extended cassettes and roller shoes for higher loads</li> <li>Connections for central lubrication</li> <li>Individual design of the cassettes (e. g. with spindle acceptance or connection of measuring systems)</li> <li>High-load raceways for use with linear motors</li> </ul>				
<b>Advantages</b>	<ul style="list-style-type: none"> <li>Easier and quieter running thanks to large-size rollers</li> <li>Fast response behaviour</li> <li>No stick-slip effect</li> <li>Slide resistance can be adjusted up and down</li> <li>Aluminium body materials harmonise perfectly with aluminium carrier profiles and facilitate design of lighter constructions</li> </ul>				
<b>Use</b>	<ul style="list-style-type: none"> <li>High precision</li> <li>High load capacity</li> </ul>	<ul style="list-style-type: none"> <li>Reasonable price</li> </ul>	<ul style="list-style-type: none"> <li>Corrosion-resistant</li> </ul>	<ul style="list-style-type: none"> <li>Non-magnetic materials</li> </ul>	<ul style="list-style-type: none"> <li>Lubricant-free and clean</li> </ul>
<b>Use</b>	<ul style="list-style-type: none"> <li>For high loads in all applications</li> </ul>	<ul style="list-style-type: none"> <li>For low loads in all applications</li> </ul>	<ul style="list-style-type: none"> <li>For medium loads in moist or aggressive environment</li> </ul>	<ul style="list-style-type: none"> <li>For light loads in magnetic fields or radiation rooms</li> </ul>	<ul style="list-style-type: none"> <li>For medium loads under extremely hygienic conditions</li> </ul>
<b>Sizes (mm)</b> Standard Special	12 – 45	12 – 45	15 – 45	25	12 – 45
	<ul style="list-style-type: none"> <li>Sizes and special shapes for series production at customer's request</li> </ul>				
<b>Travelling speed</b> V <sub>max</sub> (m/s) Acceleration (m/s <sup>2</sup> )	10 40	10 40	10 40	2 10	1 10
<b>Rail length (mm)</b> one-piece	4000	4000	4000	4000	4000
	<ul style="list-style-type: none"> <li>Can be continuously coupled for longer stroke</li> </ul>				
<b>More on page</b>	78 – 79	80 – 81	82 – 83	84 – 85	86 – 87

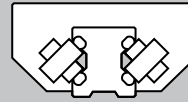

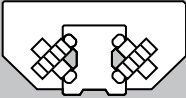
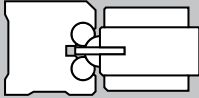
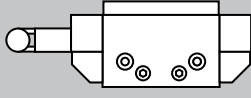
		Recirculating Rollers Franke Power	Recirculating Ball Guide Franke Robust	Systems
<b>FDG</b> Non-corrosive low cost	<b>FDH</b> High dynamic	<b>FPA</b> Standard 	<b>FRA</b> Standard 	<b>FTB, FTC, FTD, FTH</b>  <b>NEW</b>
<ul style="list-style-type: none"> <li>Non-corrosive raceways</li> <li>Ball bearing non-corrosive rollers</li> </ul>	<ul style="list-style-type: none"> <li>Steel raceways</li> <li>2-row bearing rollers</li> </ul>	<ul style="list-style-type: none"> <li>Aluminium body material</li> <li>Steel raceways</li> <li>2 rows of recirculating rollers, arranged at 90° angles</li> <li>Plastic wiper</li> <li>Lubricating nipple</li> </ul>	<ul style="list-style-type: none"> <li>Aluminium body material</li> <li>Steel raceways</li> <li>1 row of recirculating balls, balls with dividers</li> <li>Felt wiper</li> </ul>	<ul style="list-style-type: none"> <li>Linear tables/modules with spindle, belt or linear motor drive, motors, CNC controls</li> <li>Integrated Franke Linear Systems</li> </ul>
		<ul style="list-style-type: none"> <li>Slide resistance set ex works</li> <li>Cassette prefitted on raceway</li> </ul>	<ul style="list-style-type: none"> <li>Non-corrosive or non-magnetic raceways</li> <li>Bore shape to specifications</li> </ul>	<ul style="list-style-type: none"> <li>Complete multi-axe systems</li> <li>Mounting angle</li> <li>Measuring systems</li> <li>Special sizing and bore shapes available for series production</li> <li>Niro version</li> </ul>
<ul style="list-style-type: none"> <li>Corrosion-resistant</li> <li>Reasonable price</li> </ul>	<ul style="list-style-type: none"> <li>Fast response behaviour</li> </ul>	<ul style="list-style-type: none"> <li>High stiffness</li> <li>High load capacity</li> <li>High moment load rating</li> <li>All-round sealing</li> <li>Relubrication possible via funnel-type lubricating nipple</li> <li>Lubrication connection possible on 4 sides</li> </ul>	<ul style="list-style-type: none"> <li>High load rating</li> <li>High lifetime</li> <li>Robust also under severe conditions</li> <li>Shock and impact-resistant</li> <li>High stiffness</li> </ul>	<ul style="list-style-type: none"> <li>Free choice of motorisation</li> <li>Highest dynamic</li> <li>Compact dimensions</li> <li>Linear motor module with wear-free drive</li> </ul>
<ul style="list-style-type: none"> <li>For low loads in moist or aggressive environment</li> </ul>	<ul style="list-style-type: none"> <li>For high loads and high accelerations</li> </ul>	<ul style="list-style-type: none"> <li>For high loads and moment loading in heavy load operation</li> </ul>	<ul style="list-style-type: none"> <li>For applications with the highest loads in harsh environments</li> </ul>	<ul style="list-style-type: none"> <li>For automation, measuring and testing applications, recirculating, processing, mounting</li> </ul>
12 – 45	25 – 45	25	06 – 13	15 – 35
10 40	10 40	3 40	3 30	10 100
4000	4000	4000 continuously coupled	4000 continuously coupled	7000 –
88 – 89	90 – 91	92 – 93	94 – 95	96 – 105

# Linear Systems in Practice

The Franke principle of the guided roller guarantees easy and silent running, even at high speeds. These factors are essential for smooth production in many industries. Therefore, Franke Linear Systems are also used in the most diverse industrial sectors – for example in medical technology, the food industry, for machine and plant engineering or in the handling sector.

## In Medical Technology: Dental X-Ray Equipment



Precise x-rays need the movement of the light unit to be completely vibration-free. Therefore, the roller guide used must have smooth and silent running. The Franke Dynamic Aluminium Roller Guide fulfils this demand perfectly.

### The Features:

- The Franke Dynamic Aluminium Roller Guide has lifetime lubrication.
- Sealed rollers prevent the lubricant escaping.
- The guide's running is silent, smooth and even.
- Preloading the cassette ensures vibration-free movement of the secondary light.

## In the Packing Industry: Bakery Machinery

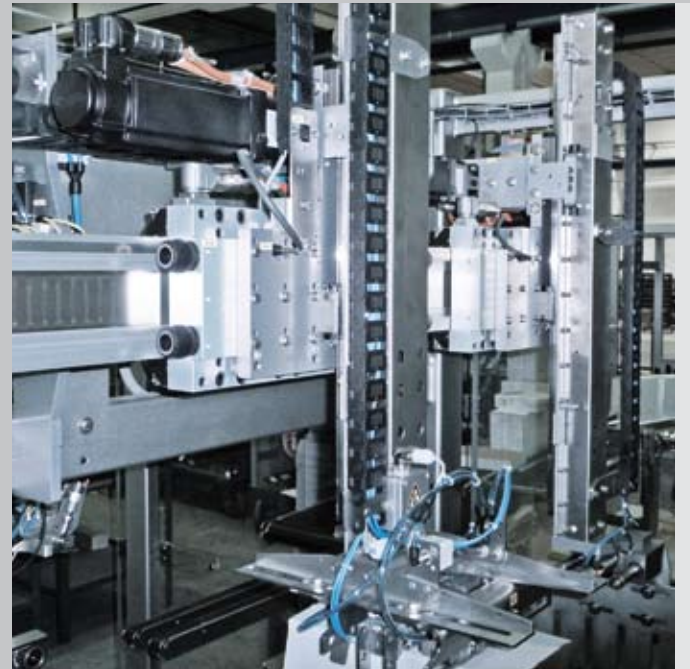

A fast, clean and maintenance-free linear system is required in a packing machine for baking mixes. Two retractable axles must be able to run simultaneously on the longitudinal module. The high dynamic of the guide results in correspondingly high cycle times when packing.

### The Features:

- The system of embedded raceways facilitates the use of light-weight, extruded aluminium profiles for the guide rails, the magnets of the stator are directly integrated; the motor rests in an aluminum housing.
- The direct drive facilitates fast positioning that is free from clearance.
- The guide achieves movement speeds of 6 m/s and acceleration of up to 100 m/s<sup>2</sup>.
- Sealed rollers prevent the lubricant escaping.

## In the Food Industry: Cheese Production



In cheese production the food-safe Franke Dynamic Aluminium Roller Guide provides the vertical movement of a gripper for wheels of cheese. In this application it is important that the roller guide is insensitive to whey and aggressive cleaning agents.

### The Features:

- The guide is insensitive to moisture.
- Its running is easy and silent, the drive power is low.
- No maintenance and lubrication for the whole lifetime are guaranteed.
- An integrated wiper fulfils the specific hygiene requirements for food production.
- The product is available in a lubricant-free version on request.

## In the Packing Industry: Bag Former/Filler



A bag forming, filling and sealing machine works at high speeds. It has stroke lengths of 1500 to 2100 mm, the average service performance is 30000 kilometers a year. The Franke Dynamic Aluminium Roller Guide used must be resistant to the aggressive environmental conditions, such as salt, sugar and splash water.

### The Features:

- The Franke Dynamic Aluminium Roller Guide is in a position to realise speeds up to 10 m/s.
- Several guides can be coupled for any length of stroke desired.
- A good lifetime and service performance are achieved through central lubrication of the cassette.

# Linear Systems in Practice

## In Plant Engineering: Packaging Machines



The Franke Dynamic Aluminium Roller Guide is also used on packaging machinery for mattresses. In addition to cleanliness, the mobile function of the guide unit must be ensured, to avoid soiling the mattresses.

### The Features:

- The Franke Dynamic Aluminium Roller Guide is maintenance-free and requires no relubrication.
- No lubricant can escape from the encapsulated rollers.
- The guide is available in a completely lubricant-free design on request.

## In the Handling Sector: High Speed Camera Guiding



The Franke Dynamic Aluminium Roller Guide moves the high speed camera for a film printing machine. A results check is performed during the printing process by camera or video. As films of different widths are printed, the camera must be easy to position.

### The Features:

- The Franke Dynamic Aluminium Roller Guide has smooth, even running.
- It weighs very little as the body material of the rail is aluminium.
- Special borings guarantee connection to the path measuring system.

## In Machinery: Ring and Drum Coilers



The Franke Power Aluminium Recirculating Roller Guide is used for machines that process and pack coiled goods. It ensures that cables, hoses or steel ropes are coiled on rings or empty spools, measured to length and cut.

### The Features:

- The Franke Power Aluminium Roller Guide has high load-capacity and stiffness.
- The cassettes are completely sealed and are also suitable for harsh conditions.
- Integrated metal wipers keep the raceways clean.

## In Machinery: Handling System



Different processing centres are coupled together in this machine through large portals. Workpieces are processed with high acceleration. The Franke Robust Aluminium Recirculating Ball Guide is used in the transfer line. The recirculating ball system of type FRA10 and FRA13 harmonises perfectly with the substructure of aluminium profiles.

### The Features:

- Transfer speeds of up to 3 m/s and accelerations of up to 30 m/s<sup>2</sup> are achieved.
- The Franke Robust Aluminium Recirculating Ball Guides used have a high lifetime, even in harsh and very dirty conditions.
- Tolerances and unevenness in the substructure can be equalised to a certain extent.

# Franke Dynamic

## Aluminium Roller Guide – Advantages and Characteristics

Type FDA – FDH

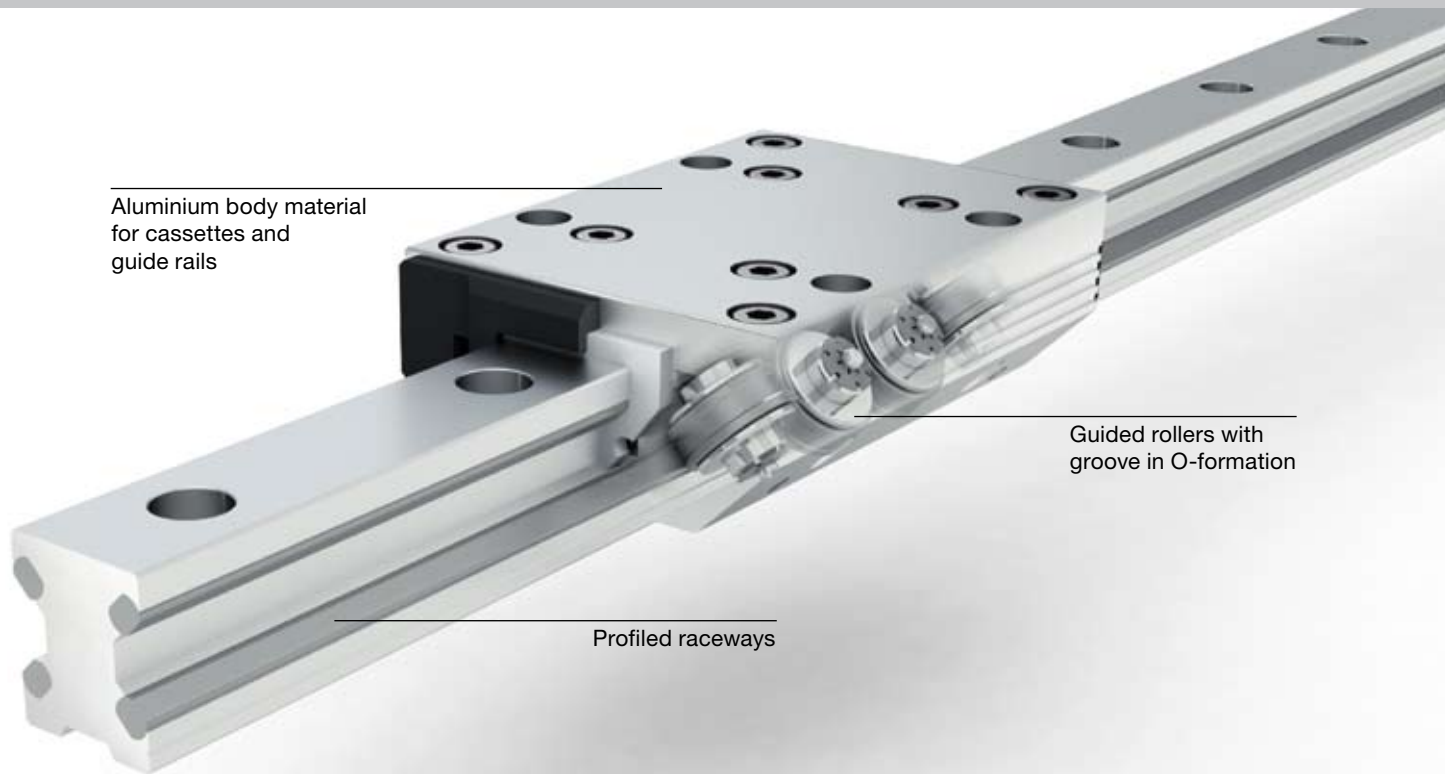

### The Characteristics:

#### Cassettes and Roller Shoes

The cassette of the Franke Dynamic Aluminium Roller Guide has aluminium body material with needle or ball bearing rollers of steel or stainless steel. Special cover discs on the roller seal the bearing to the outside.

Eight rollers in O-formation guarantee an equally high load capacity from all directions. The rollers are equipped with a groove, which is adjusted to the profile of the raceway. Thanks to this patented system of guided rollers, the rollers are guided laterally and equally smooth and silent running is guaranteed.

The cassette plate has mounting holes in accordance with international standards. The slide resistance can be adjusted up and down individually using a setting screw on the side. Five standard sizes are available from size 12 to 45.

In the pair of single rails with roller shoes version there is no cassette plate. As a result, the guide width can be selected freely. The roller shoes are screwed directly to the mating structure and facilitate extremely compact assemblies.

Thread pieces for one-sided adjustability of the slide resistance are supplied and can be integrated.



## The Advantages:

- Low weight thanks to aluminium body material
- Silent and easy running thanks to the patented **Guided Roller®**
- Maintenance-free and clean
- O-formation for equal loads from all directions
- High traverse speed and acceleration
- Numerous variations for almost any application
- Customer-specific solutions if series needed



### Wipers

The bearings of the rollers are sealed and have lifetime lubrication. Thanks to the standard felt wiper, lasting protection of the guide system from soiling is guaranteed.

Metal wipers are included as accessories, which are particularly recommended for coarse dirt such as chippings or sawdust and keep the raceway clean (see accessories page 106).

Lubricant-free cassettes and roller shoes are available as type FDE. They are also suitable for hygienically sensitive sectors, for example the food industry or medical technology.

### Guide Rails

The raceways of spring steel, non-corrosive or non-magnetic steel are integrated in the aluminium profile. The O-formation guarantees high load capacity from all directions. The profile of the rollers is adjusted to the raceway and guarantees permanently precise and smooth running.

The guide rails are available in one piece up to a length of four meters. They can be continuously coupled for longer strokes. we can supply rail profiles specially tailored to your design on request.

Franke precision raceways of spring steel, non-corrosive or non-magnetic steel can be integrated into a variety of aluminium profiles. We can supply your chosen profile complete with integrated raceways in series production.

We also offer specially hardened raceways for the heaviest loads.

# Franke Dynamic

## Aluminium Roller Guide – Numerous Possibilities

### The Different Types:

<b>Type FDA</b>	<b>Standard</b>
<b>Type FDB</b>	<b>Low cost</b>
<b>Type FDC</b>	<b>Non-corrosive</b>
<b>Type FDD</b>	<b>Non-magnetic</b>
<b>Type FDE</b>	<b>Lubricant-free</b>
<b>Type FDG</b>	<b>Non-corrosive low cost</b>
<b>Type FDH</b>	<b>High dynamic</b>

We can also supply special cassettes in specific dimensions, heat-resistant versions and vacuum-fit for series production. Please call us.

### Further Possibilities:

#### Design

For series production it is possible to adjust the shape and design of the cassettes, roller shoes and guide profiles to your individual application. You will get the perfect solution tailored to your requirements.

Adjustment options are:

- Shortened or extended roller shoes/cassettes
- Special shapes, e.g. for integration of drives
- Special profiles of guide rails according to your needs
- Individual bore shapes on the guide rails
- Fixing from underneath

#### Vacuum/High Temperature

We also offer special cassettes and roller shoes for applications in vacuums. They are designed with free borings and equipped with lubricants suited to high vacuums on request.

You can choose from a selection of special, heat-resistant cassettes and roller shoes for applications with radiant heat in the vicinity of heat sources.

Temperature ranges up to 200 °C are possible.





### Complete Systems

The Franke Dynamic Aluminium Roller Guides are also used in our complete systems of linear axis, drive, motorisation and control. Franke Linear Modules and Linear Tables use the assets of Linear Systems to build-up complete moving units.

Toothed belt gear Linear Modules are available up to a stroke length of 7000 mm. The integrated Franke Dynamic Aluminium Roller Guide provides high dynamic movements and easy and silent running.

### Clean Room

The Franke Dynamic Aluminium Roller Guide was appraised and evaluated at the Institut für Produktionstechnik und Automatisierung (IPA) at the Fraunhofer Gesellschaft (FhG) in Stuttgart with regard to its operation in rooms with high air purity rates.

It is extremely suitable for the listed loading conditions. The trends of the results (e.g. particle emissions on increase of the moved mass) allow us to state that a suitability for "Class 1000" is also achieved for higher loads.

The result: the Franke Dynamic Aluminium Roller Guide of type FDA is suitable for clean room-typical movement speeds for use in clean rooms with air purity classes "Class 1000".



# Franke Power

## Aluminium Recirculating Roller Guide

Type FPA

### The Advantages:

- High load capacity and stiffness
- Connecting dimensions compatible with international standards
- Integrated metal wipers
- All-round sealing

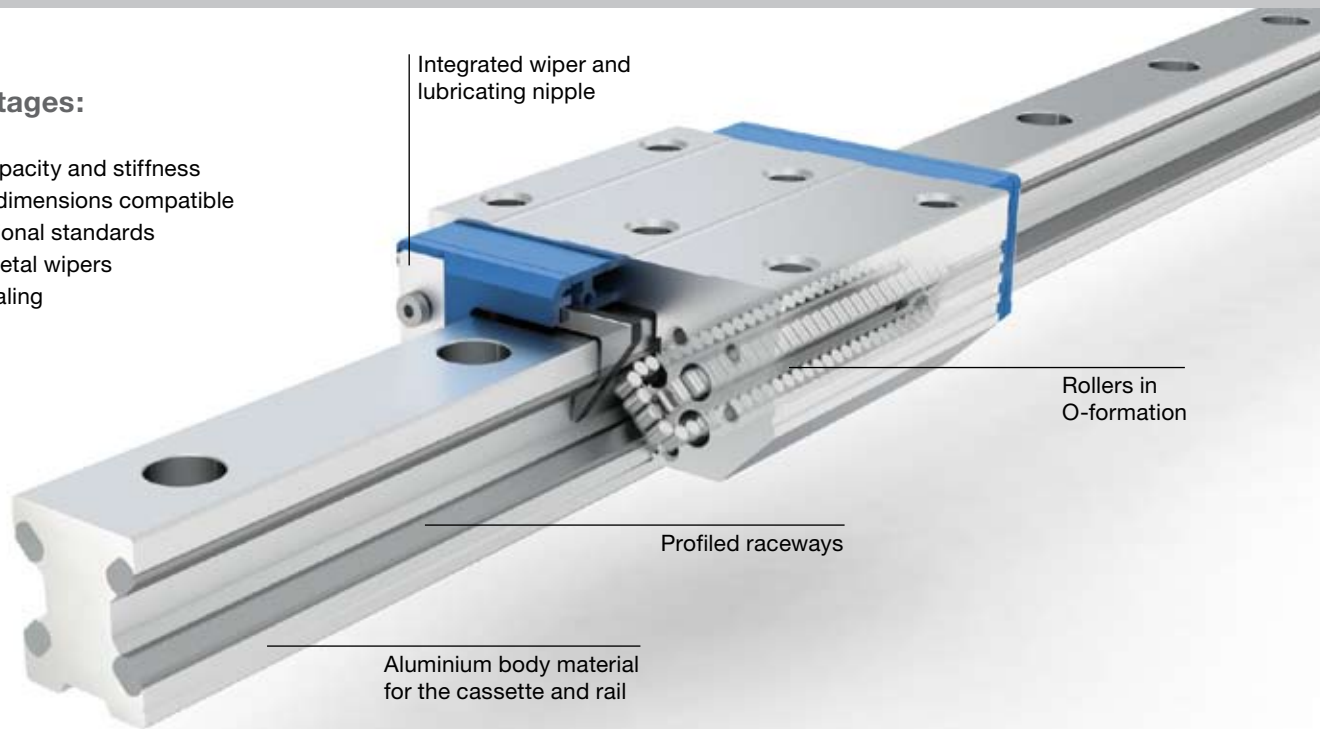

### The Characteristics:

#### Cassette

The cassette of the Franke Power Aluminium Recirculating Roller Guide is made from special aluminium with fixing bores in accordance with international standards and, therefore, is interchangeable with products from many manufacturers. Wear-resistant plastic seals provide all-round sealing for the cassette. The additional frontal metal wipers are adjusted to the rail contour and protect the guide system from coarse impurities.

The recirculating rollers in 90°-formation guarantee even, high load capacity and loading from every direction. Each cassette has a lubrication nipple, which can be attached to one of the four front ends. A defined slide resistance ensures alignment on the guide rails. It is supplied with a preload class with light preload. The guides can be mounted on unprocessed surfaces without impairing the lifetime. The inner elasticity of the Recirculating Roller Guide is ensured by a system patented by Franke.

#### Guide Rails

Raceways of spring steel, non-corrosive or non-magnetic steel are integrated in the aluminium profile. High load capacity from all directions is guaranteed by the O-formation. The profile of the rollers is adjusted to the raceway and ensures precise and easy running permanently.

The guide rails can be supplied as one piece up to a length of four meters and can be coupled together endlessly for longer strokes. We can supply bore shapes specially tailored to your design on request.

# FTH Drive

## Aluminium Linear Motor Module

Type FTH



### The Advantages:

- Low space requirement (height)
- Greater closeness of the system (no double-track rail set-up), so simpler to clean and less risk of contamination
- Reduced components

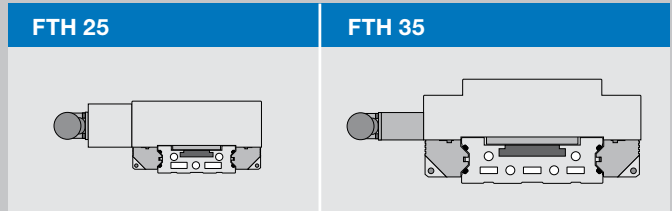
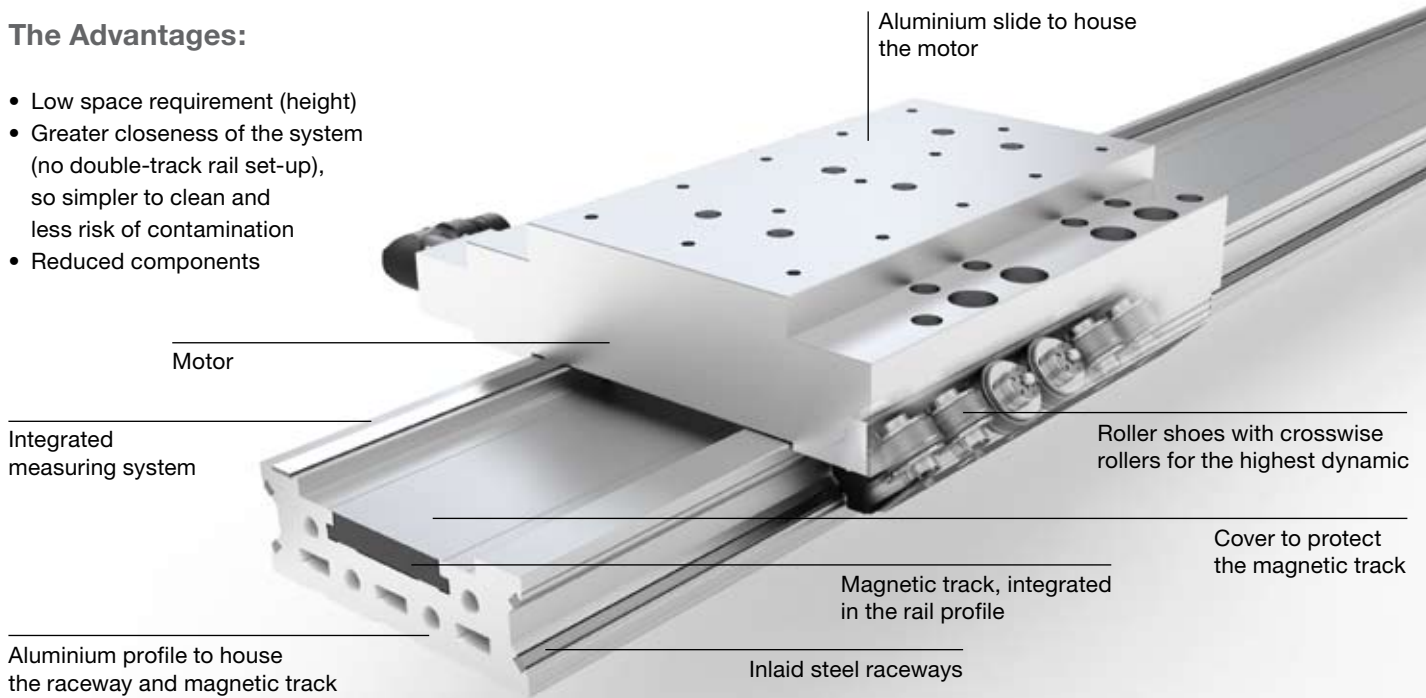

### The Characteristics:

#### Roller Shoes and Guide Rails

Building on the proven Franke Aluminium Roller Guide, the Linear Motor Module FTH impresses with its low weight and compact dimensions. The roller shoes have been specially designed for high loads. The rail profile was designed so that the stator could be integrated. This saves height and weight. The modular design of the system enables numerous adjustments according to the individual use.

#### Multi-Module Systems

In addition to customer-specific mating and profile dimensions, several slides can be moved independently of one another per module. Complete multi-module systems using angles and adapter plates is also possible. We can supply the Linear Motor Module with all wiring and tailored to your desired control mode on request.

### The Franke FTH Drive in comparison to conventional products

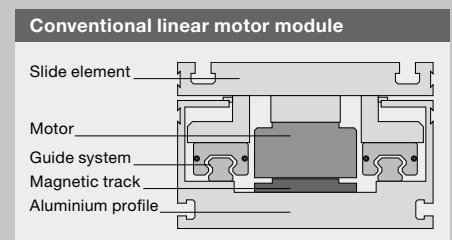
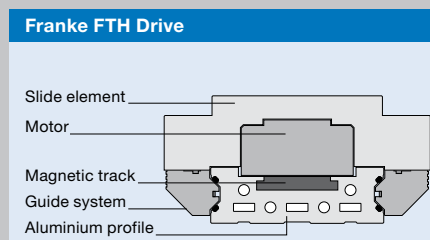

### Cassette + double rail

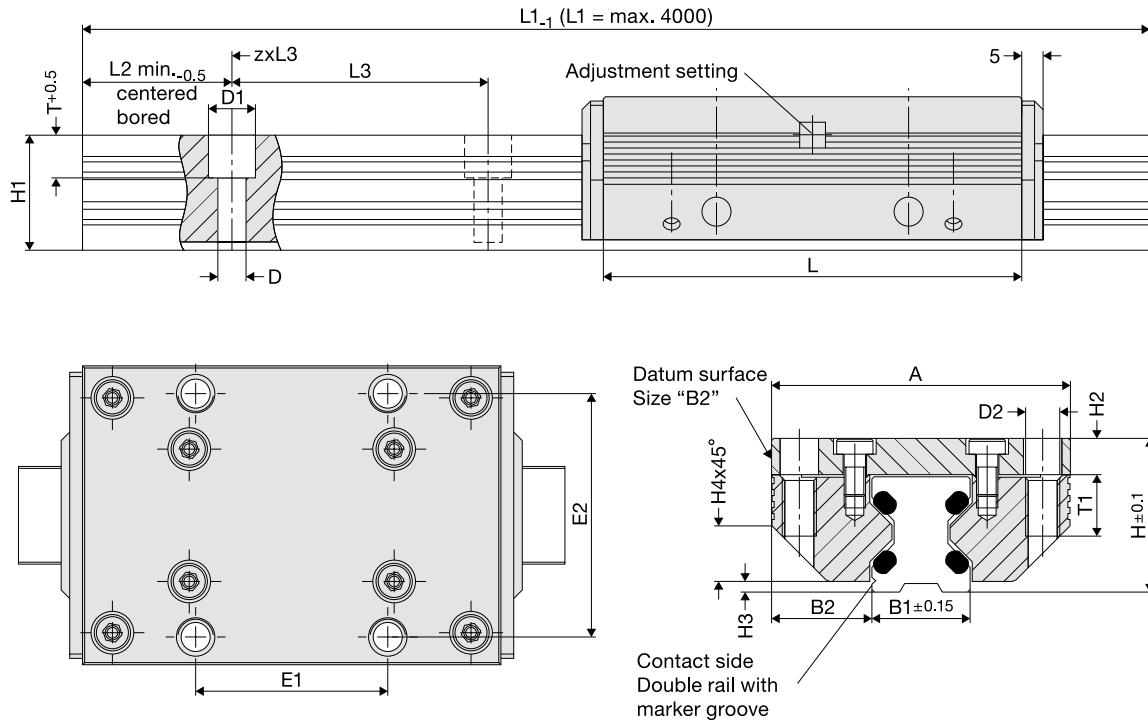

### Dimensions

Size	Dimensions																	
	A	L	H	B1	B2	D	D1	D2	E1	E2	H1	H2	H3	H4	L2	L3	T	T1
12	37	64	19	12.0	12.50	3.4	6	M 4	25	30	14.7	4.0	1.4	5.5	10	40	5.5	8
15	47	78	24	15.5	15.75	4.5	8	M 5	30	38	18.7	5.0	2.0	8.0	10	60	6.0	10
20	63	92	30	21.0	21.00	5.5	10	M 6	40	53	22.6	7.0	2.0	11.0	10	60	8.0	12
25	70	98	36	23.0	23.50	6.6	11	M 8	45	57	27.0	8.5	2.5	13.0	10	60	10.0	16
35	100	135	48	32.0	34.00	9.0	15	M10	62	82	37.0	10.5	3.5	20.0	12	80	11.5	20
45	120	165	60	45.0	37.50	11.0	18	M12	80	100	46.0	13.5	4.0	22.0	16	105	14.5	24

### Load ratings, weight

Size	Load ratings		Moment load ratings* cassette				Weight	
	N	Co	Mocx	Mcx	Mocy/Mocz	Mcy/Mcz	Cassette	kg
12	2800	3000	27	25	43	40	0.1	0.4
15	4200	3400	37	45	58	72	0.2	0.8
20	5400	5400	76	76	111	111	0.4	0.9
25	9000	10100	158	142	222	198	0.5	1.8
35	12500	18000	423	294	559	388	1.4	3.2
45	21200	25900	827	678	983	806	2.5	5.5

### Order numbers

Order no.	Order key
Cassette	Double rail
84494A	e.g. <b>FDA25D1500</b> 
84396A	
84441A	
84363A	
84364A	
84365A	Size

\*There is more information on moment load ratings on page 110/111.

\*\*Guide rails up to 4000 mm on one piece. Longer strokes are coupled.

## Materials

	Body material	Rollers	Wipers
<b>Standard</b>	High-strength, anodized aluminium	Antifriction bearing steel	Plastic plate with felt wiper

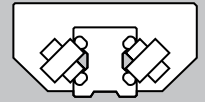

## Pair of roller shoes + single rail pairs

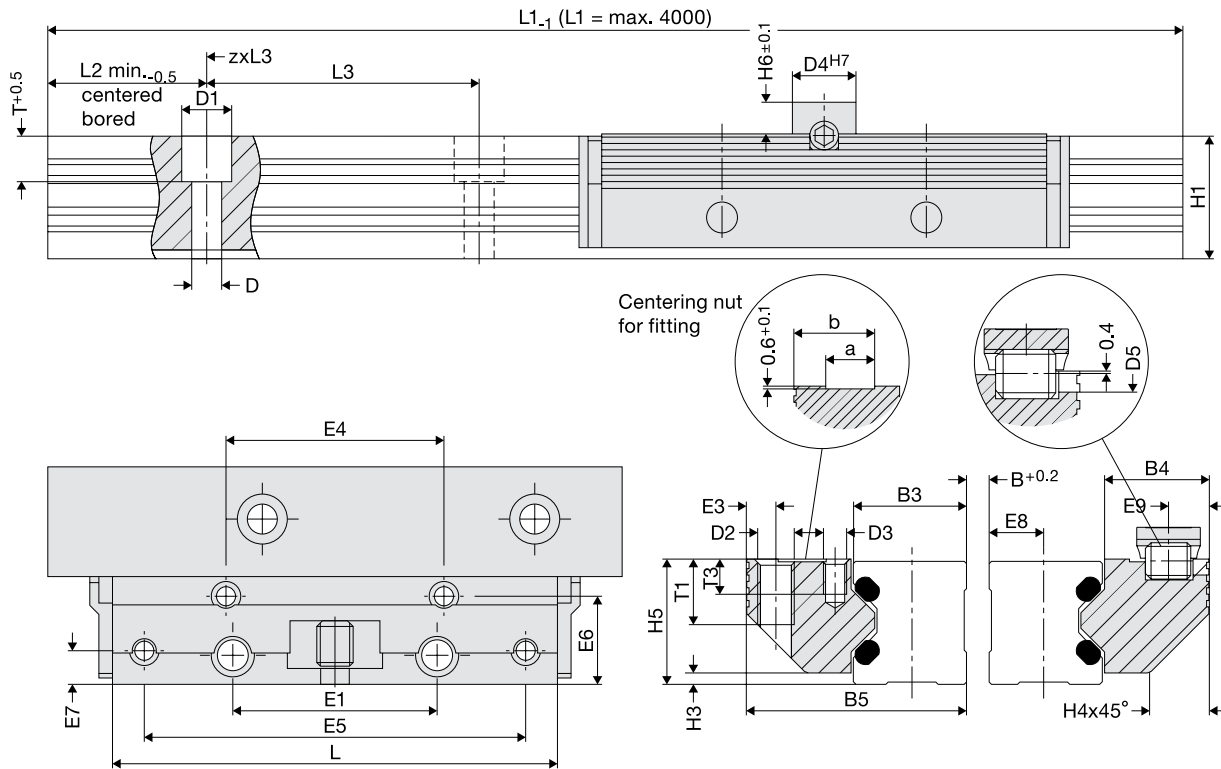

## Dimensions

Size	Dimensions																	
	B5	H5	B3	B4	D3	D4	D5	E3	E4	E5	E6	E7	E8	E9	H6	T3	a	b
12	24.4	15.0	12.00	11.9	M3	8	3	3.4	29	57	9.7	3.4	5.5	4.9	4	6.0	4.5	9.5
15	30.9	19.0	15.25	15.2	M4	10	4	4.4	34	68	12.4	4.9	7.0	5.9	5	7.5	5.0	12.5
20	40.9	23.0	20.00	20.4	M5	10	4	4.9	42	80	16.9	5.9	9.5	5.9	5	8.0	7.5	16.0
25	48.4	27.5	25.00	22.9	M5	14	6	6.4	48	84	19.4	7.4	12.0	8.9	7	5.0	10.5	17.5
35	68.9	37.5	35.00	32.9	M6	14	6	8.9	67	117	28.4	8.9	17.0	8.9	7	7.5	12.5	26.0
45	82.4	46.5	45.00	36.4	M8	14	6	9.9	83	146	30.9	9.9	22.0	8.9	7	9.5	15.5	31.0

## Load ratings, weight

Size	Load ratings		Moment load ratings* RSP				Weight		
	N	Co	Nm		Nm		kg	rail/m	
	C	Co	Mocx	Mcx	Mocy/Mocz	Mcy/Mcz	RSP		
12	2800	3000	1.5(B+ 30.3)	1.4(B+ 30.3)		43	40	0.07	0.4
15	4200	3400	1.7(B+ 36.5)	2.1(B+ 36.5)		58	72	0.12	0.8
20	5400	5400	2.7(B+ 47.0)	2.7(B+ 47.0)		111	111	0.23	1.0
25	9000	10100	5.0(B+ 58.4)	4.5(B+ 58.4)		222	198	0.34	1.9
35	12500	18000	9.0(B+ 85.0)	6.3(B+ 85.0)		559	388	0.99	3.5
45	21200	25900	12.9(B+109.0)	10.6(B+109.0)		983	806	1.79	5.6

\*There is more information on moment load ratings on page 110/111.

## Order numbers

Order no.	Order key
RSP	Single rail pair
84495A	e.g. <b>FDA25E1500</b> 
84395A	
84442A	
84367A	
84368A	
84369A	Single rail

\*\*Guide rails up to 4000 mm on one piece. Longer strokes are coupled.

## Cassette + double rail

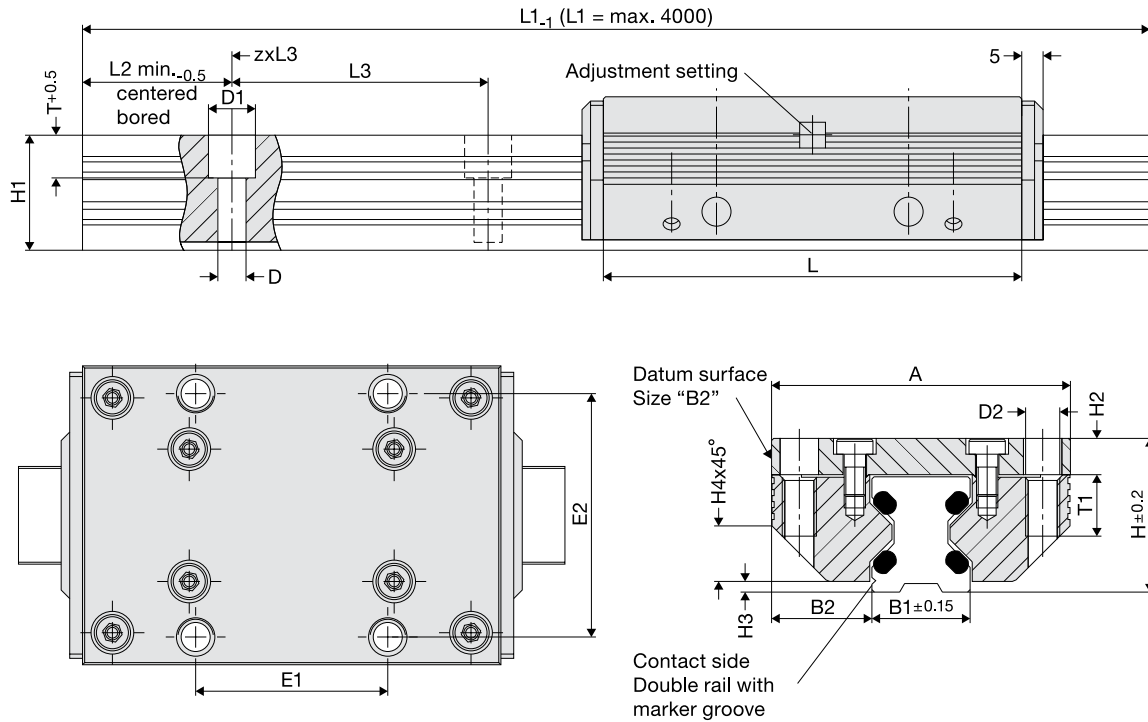

## Dimensions

Size	Dimensions																	
	A	L	H	B1	B2	D	D1	D2	E1	E2	H1	H2	H3	H4	L2	L3	T	T1
12	37	64	19	12.0	12.50	3.4	6	M 4	25	30	14.7	4.0	1.4	5.5	10	40	5.5	8
15	47	78	24	15.5	15.75	4.5	8	M 5	30	38	18.7	5.0	2.0	8.0	10	60	6.0	10
20	63	92	30	21.0	21.00	5.5	10	M 6	40	53	22.6	7.0	2.0	11.0	10	60	8.0	12
25	70	98	36	23.0	23.50	6.6	11	M 8	45	57	27.0	8.5	2.5	13.0	10	60	10.0	16
35	100	135	48	32.0	34.00	9.0	15	M10	62	82	37.0	10.5	3.5	20.0	12	80	11.5	20
45	120	165	60	45.0	37.50	11.0	18	M12	80	100	46.0	13.5	4.0	22.0	16	105	14.5	24

## Load ratings, weight

Size	Load ratings		Moment load ratings* cassette				Weight	
	C	Co	Mocx	Mcx	Mocy/Mocz	Mcy/Mcz	Cassette	rail/m
12	620	170	1.6	5.7	2.4	8.9	0.1	0.4
15	700	230	2.5	7.5	4.0	12.0	0.2	0.8
20	940	300	4.0	13.0	6.0	19.0	0.4	0.9
25	1500	700	11.0	23.0	15.0	32.0	0.5	1.8
35	3100	1400	32.0	72.0	42.0	95.0	1.4	3.2
45	6300	2700	86.0	200.0	103.0	238.0	2.5	5.5

## Order numbers

Order no.	Order key
Cassette	Double rail
84494L	e.g. <b>FDA25D1500</b> 
84396L	
84441L	
84363L	
84364L	
84365L	Size

\*There is more information on moment load ratings on page 110/111.

\*\*Guide rails up to 4000 mm on one piece. Longer strokes are coupled.



## Materials

	Body material	Rollers	Wipers
<b>Standard</b>	High-strength, anodized aluminium	Antifriction bearing steel	Plastic plate with felt wiper

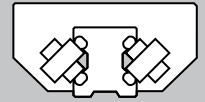

## Pair of roller shoes + single rail pairs

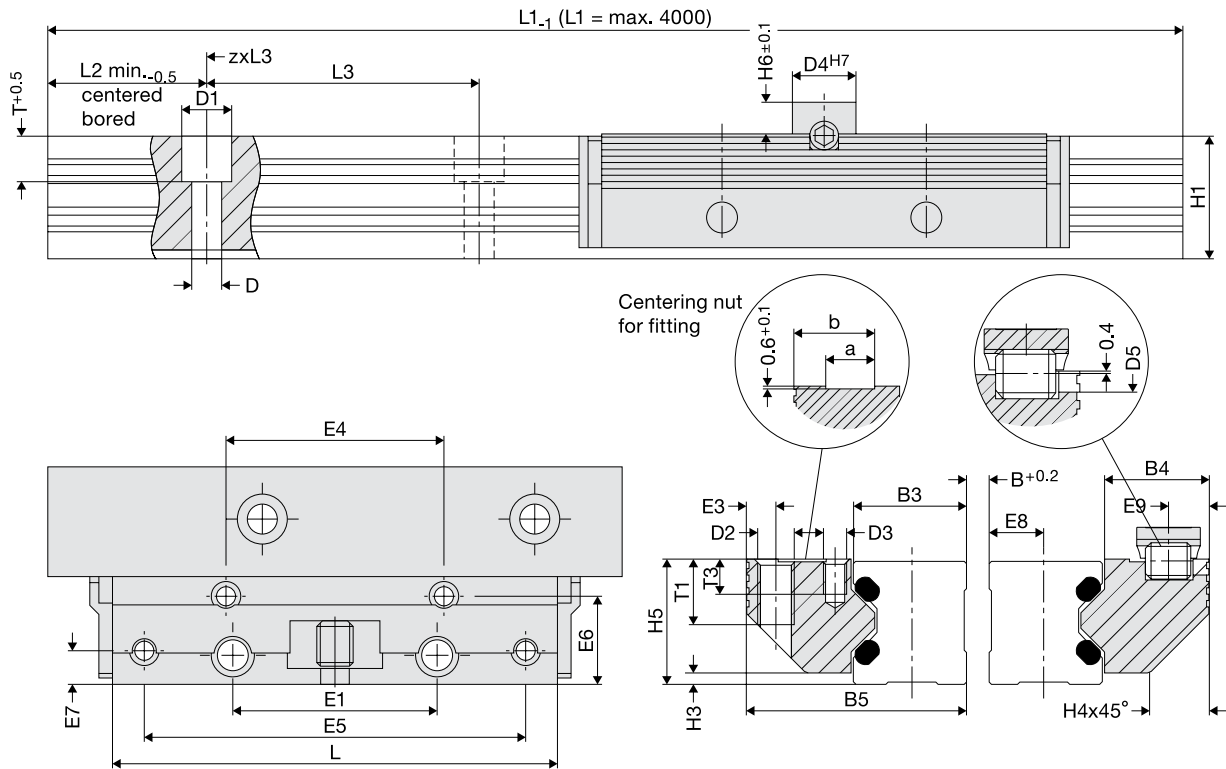

## Dimensions

Size	Dimensions																		
	B5	H5	B3	B4	D3	D4	D5	E3	E4	E5	E6	E7	E8	E9	H6	T3	a	b	
12	24.4	15.0	12.00	11.9	M3	8	3	3.4	29	57	9.7	3.4	5.5	4.9	4	6.0	4.5	9.5	
15	30.9	19.0	15.25	15.2	M4	10	4	4.4	34	68	12.4	4.9	7.0	5.9	5	7.5	5.0	12.5	
20	40.9	23.0	20.00	20.4	M5	10	4	4.9	42	80	16.9	5.9	9.5	5.9	5	8.0	7.5	16.0	
25	48.4	27.5	25.00	22.9	M5	14	6	6.4	48	84	19.4	7.4	12.0	8.9	7	5.0	10.5	17.5	
35	68.9	37.5	35.00	32.9	M6	14	6	8.9	67	117	28.4	8.9	17.0	8.9	7	7.5	12.5	26.0	
45	82.4	46.5	45.00	36.4	M8	14	6	9.9	83	146	30.9	9.9	22.0	8.9	7	9.5	15.5	31.0	

## Load ratings, weight

Size	Load ratings		Moment load ratings* RSP				Weight		
	N	Co	Mocx	Mcx	Mocy/Mocz	Mcy/Mcz	RSP	kg rail/m	
12	620	170	0.08(B+ 30.3)	0.30(B+ 30.3)		2.4	8.9	0.07	0.4
15	700	230	0.10(B+ 36.5)	0.35(B+ 36.5)		4.0	12.0	0.12	0.8
20	940	300	0.15(B+ 47.0)	0.50(B+ 47.0)		6.0	19.0	0.23	1.0
25	1500	700	0.35(B+ 58.4)	0.70(B+ 58.4)		15.0	32.0	0.34	1.9
35	3100	1400	0.70(B+ 85.0)	1.50(B+ 85.0)		42.0	95.0	0.99	3.5
45	6300	2700	1.40(B+109.0)	3.10(B+109.0)		103.0	238.0	1.79	5.6

\*There is more information on moment load ratings on page 110/111.

## Order numbers

Order no.	Order key
RSP	Single rail pair

e.g. **FDA25E1500**

\*\*Guide rails up to 4000 mm on one piece. Longer strokes are coupled.

## Cassette + double rail

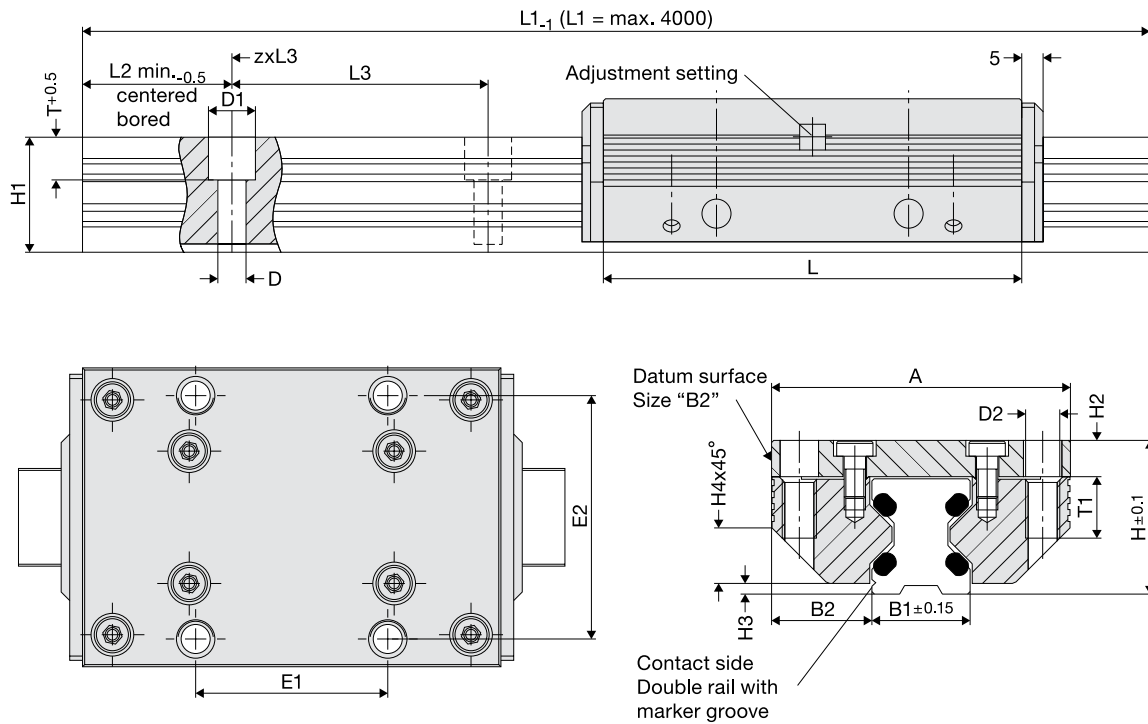

## Dimensions

Size	Dimensions																	
	A	L	H	B1	B2	D	D1	D2	E1	E2	H1	H2	H3	H4	L2	L3	T	T1
12	37	64	19	12.0	12.50	3.4	6	M 4	25	30	14.7	4.0	1.4	5.5	10	40	5.5	8
15	47	78	24	15.5	15.75	4.5	8	M 5	30	38	18.7	5.0	2.0	8.0	10	60	6.0	10
20	63	92	30	21.0	21.00	5.5	10	M 6	40	53	22.6	7.0	2.0	11.0	10	60	8.0	12
25	70	98	36	23.0	23.50	6.6	11	M 8	45	57	27.0	8.5	2.5	13.0	10	60	10.0	16
35	100	135	48	32.0	34.00	9.0	15	M10	62	82	37.0	10.5	3.5	20.0	12	80	11.5	20
45	120	165	60	45.0	37.50	11.0	18	M12	80	100	46.0	13.5	4.0	22.0	16	105	14.5	24

## Load ratings, weight

Size	Load ratings		Moment load ratings* cassette				Weight	
	C	Co	Mocx	Mcx	Mocy/Mocz	Mcy/Mcz	Cassette	rail/m
12	1100	1200	11	10	17	16	0.1	0.4
15	2700	3000	33	29	52	46	0.2	0.8
20	4300	5000	71	61	103	89	0.4	0.9
25	5800	8300	132	92	184	128	0.5	1.8
35	10000	14500	343	237	452	312	1.4	3.2
45	17000	20400	651	542	774	645	2.5	5.5

## Order numbers

Order no.	Order key
84494AN	Cassette
84396AN	Double rail
84441AN	
84363AN	
84364AN	
84365AN	

e.g. **FDC25D1500**

Type: **FDC**  
Size: **25**  
Length in mm: **1500**  
Double rail

\*There is more information on moment load ratings on page 110/111.

\*\*Guide rails up to 4000 mm on one piece. Longer strokes are coupled.

## Materials

	Body material	Rollers	Wipers
<b>Standard</b>	High-strength, anodized aluminium	Antifriction bearing steel	Plastic plate with felt wiper

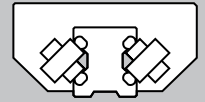

## Pair of roller shoes + single rail pairs

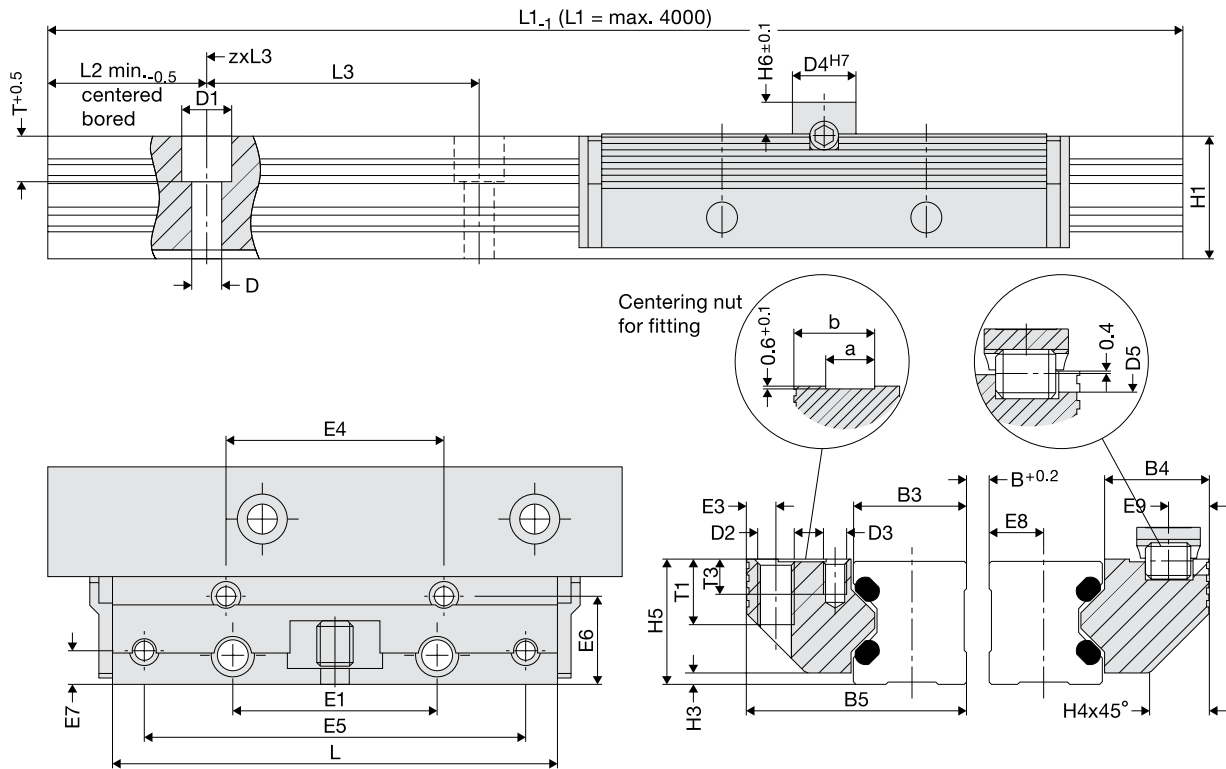

## Dimensions

Size	Dimensions																		
	B5	H5	B3	B4	D3	D4	D5	E3	E4	E5	E6	E7	E8	E9	H6	T3	a	b	
12	24.4	15.0	12.00	11.9	M3	8	3	3.4	29	57	9.7	3.4	5.5	4.9	4	6.0	4.5	9.5	
15	30.9	19.0	15.25	15.2	M4	10	4	4.4	34	68	12.4	4.9	7.0	5.9	5	7.5	5.0	12.5	
20	40.9	23.0	20.00	20.4	M5	10	4	4.9	42	80	16.9	5.9	9.5	5.9	5	8.0	7.5	16.0	
25	48.4	27.5	25.00	22.9	M5	14	6	6.4	48	84	19.4	7.4	12.0	8.9	7	5.0	10.5	17.5	
35	68.9	37.5	35.00	32.9	M6	14	6	8.9	67	117	28.4	8.9	17.0	8.9	7	7.5	12.5	26.0	
45	82.4	46.5	45.00	36.4	M8	14	6	9.9	83	146	30.9	9.9	22.0	8.9	7	9.5	15.5	31.0	

## Load ratings, weight

Size	Load ratings		Moment load ratings* RSP				Weight	
	N	Co	Nm		Nm		RSP	kg
	C	Co	Mocx	Mcx	Mocy/Mocz	Mcy/Mcz	RSP	rail/m
12	1100	1200	0.6(B+ 30.3)	0.6(B+ 30.3)	17	16	0.07	0.4
15	2700	3000	1.5(B+ 36.5)	1.4(B+ 36.5)	52	46	0.12	0.8
20	4300	5000	2.5(B+ 47.0)	2.2(B+ 47.0)	103	89	0.23	1.0
25	5800	8300	4.2(B+ 58.4)	2.9(B+ 58.4)	184	128	0.34	1.9
35	10000	14500	7.3(B+ 85.0)	5.0(B+ 85.0)	452	312	0.99	3.5
45	17000	20400	10.2(B+109.0)	8.5(B+109.0)	774	645	1.79	5.6

\*There is more information on moment load ratings on page 110/111.

## Order numbers

Order no.	Order key
RSP	Single rail pair

e.g. **FDC25E1500**

\*\*Guide rails up to 4000 mm on one piece. Longer strokes are coupled.

### Cassette + double rail

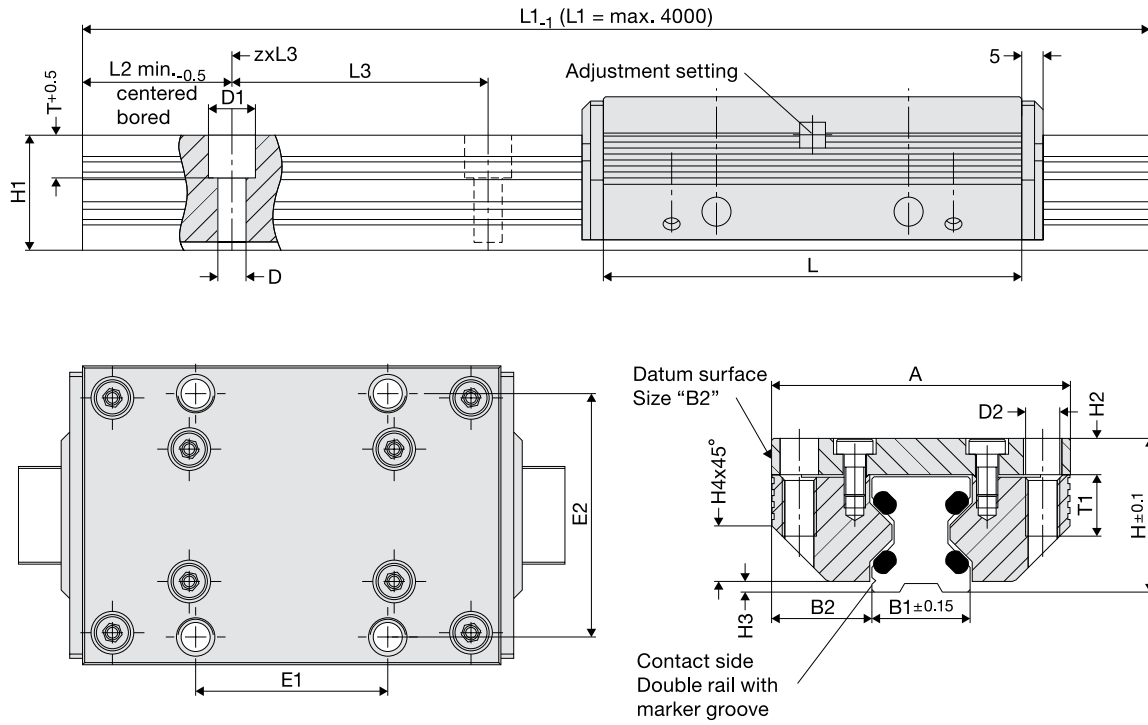

### Dimensions

Size	Dimensions																	
	mm																	
	A	L	H	B1	B2	D	D1	D2	E1	E2	H1	H2	H3	H4	L2	L3	T	T1
25	70	98	36	23.0	23.50	6.6	11	M 8	45	57	27.0	8.5	2.5	13.0	10	60	10.0	16

### Load ratings, weight

Size	Load ratings		Moment load ratings* cassette				Weight	
	N		Nm				kg	
	C	Co	Mocx	Mcx	Mocy/Mocz	Mcy/Mcz	Cassette	rail/m
25	1200	1600	25	18	35	25	0.5	1.8

### Order numbers

Order no.	Order key
Cassette	Double rail
<b>84363P</b>	e.g. <b>FDD25D1500</b>

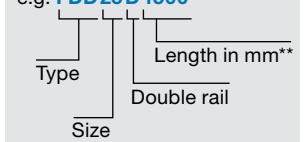

\*There is more information on moment load ratings on page 110/111.

\*\*Guide rails up to 4000 mm on one piece. Longer strokes are coupled.

## Materials

	Body material	Rollers	Wipers
<b>Standard</b>	High-strength, anodized aluminium	Antifriction bearing steel	Plastic plate with felt wiper

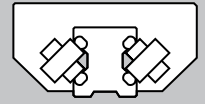

## Pair of roller shoes + single rail pairs

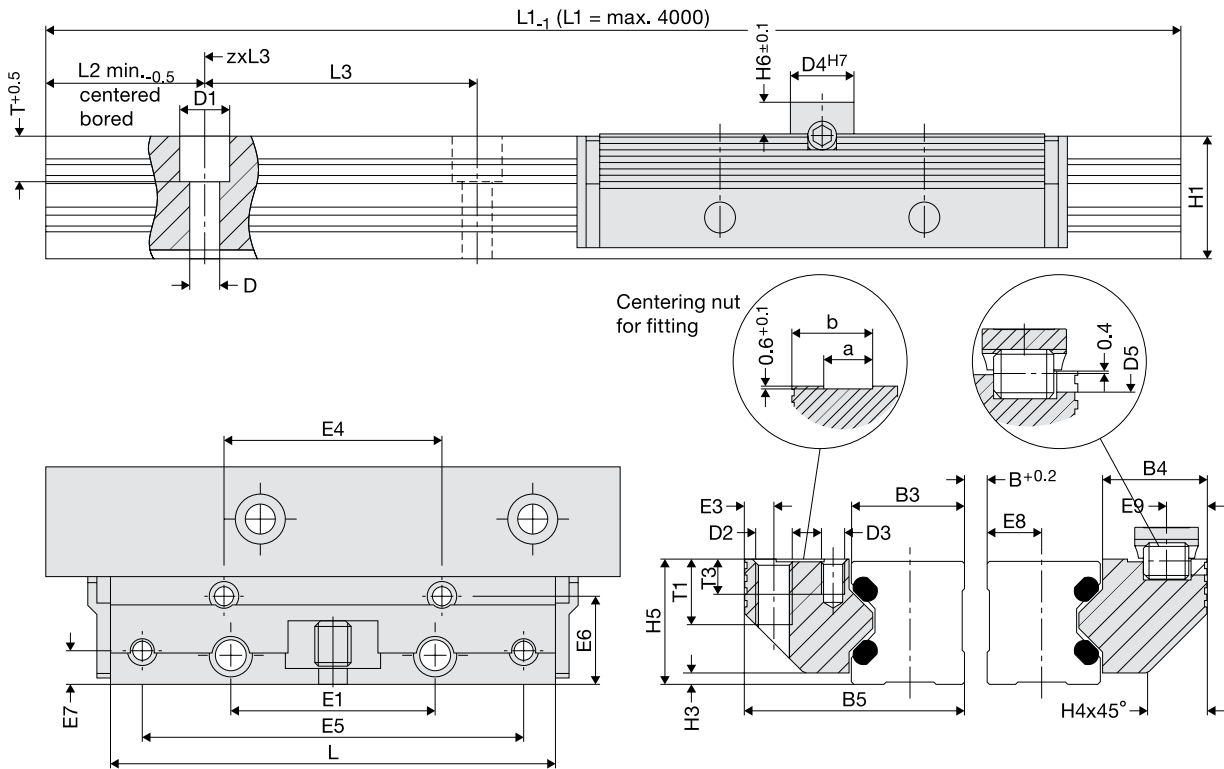

## Dimensions

Size	Dimensions																	
	B5	H5	B3	B4	D3	D4	D5	E3	E4	E5	E6	E7	E8	E9	H6	T3	a	b
25	48.4	27.5	25.00	22.9	M5	14	6	6.4	48	84	19.4	7.4	12.0	8.9	7	5.0	10.5	17.5

## Load ratings, weight

Size	Load ratings		Moment load ratings* RSP				Weight	
	N	Co	Nm		Nm		RSP	kg
	C	Co	Mocx	Mcx	Mocy/Mocz	Mcy/Mcz	RSP	rail/m
25	1200	1600	0.8(B+58.4)	0.6(B+58.4)	35	25	0.34	1.9

## Order numbers

Order no.	Order key
RSP	Single rail pair
<b>84367P</b>	e.g. <b>FDD25E1500</b>

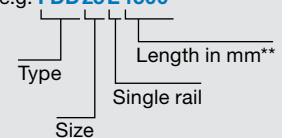

\*There is more information on moment load ratings on page 110/111.

\*\*Guide rails up to 4000 mm on one piece. Longer strokes are coupled.

## Cassette + double rail

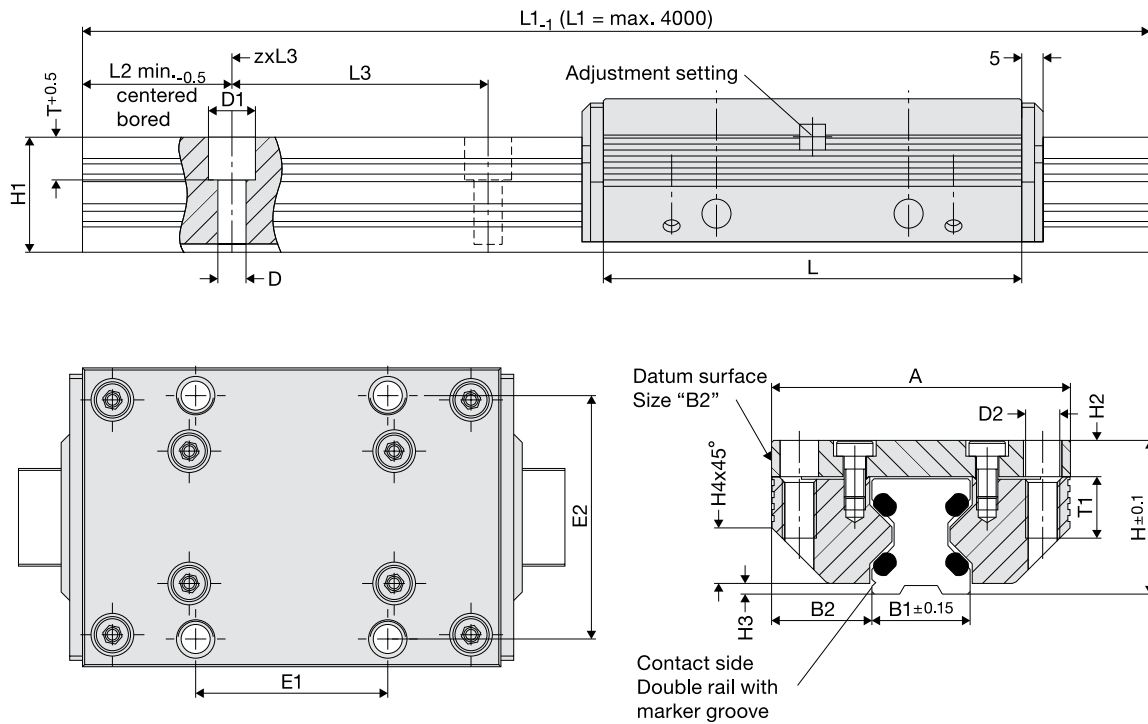

## Dimensions

Size	Dimensions																	
	A	L	H	B1	B2	D	D1	D2	E1	E2	H1	H2	H3	H4	L2	L3	T	T1
12	37	64	19	12.0	12.50	3.4	6	M 4	25	30	14.7	4.0	1.4	5.5	10	40	5.5	8
15	47	78	24	15.5	15.75	4.5	8	M 5	30	38	18.7	5.0	2.0	8.0	10	60	6.0	10
20	63	92	30	21.0	21.00	5.5	10	M 6	40	53	22.6	7.0	2.0	11.0	10	60	8.0	12
25	70	98	36	23.0	23.50	6.6	11	M 8	45	57	27.0	8.5	2.5	13.0	10	60	10.0	16
35	100	135	48	32.0	34.00	9.0	15	M10	62	82	37.0	10.5	3.5	20.0	12	80	11.5	20
45	120	165	60	45.0	37.50	11.0	18	M12	80	100	46.0	13.5	4.0	22.0	16	105	14.5	24

## Load ratings, weight

Size	Load ratings		Moment load ratings* cassette				Weight	
	N	N	Nm				kg	
	C	Co	Mocx	Mcx	Mocy/Mocz	Mcy/Mcz	Cassette	rail/m
12	350	400	4	3	6	5	0.1	0.4
15	600	700	8	6	12	10	0.2	0.8
20	700	900	12	9	17	14	0.4	0.9
25	1200	1600	25	18	35	25	0.5	1.8
35	2000	2500	58	44	76	58	1.4	3.2
45	4400	5500	180	140	210	170	2.5	5.5

## Order numbers

Order no.	Order key
Cassette	Double rail
84494T	e.g. <b>FDA25D1500</b> 
84396T	
84441T	
84363T	
84364T	
84365T	

\*There is more information on moment load ratings on page 110/111.

\*\*Guide rails up to 4000 mm on one piece. Longer strokes are coupled.

## Materials

	Body material	Rollers	Wipers
<b>Standard</b>	High-strength, anodized aluminium	Antifriction bearing steel	Plastic plate with felt wiper

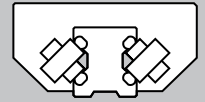

## Pair of roller shoes + single rail pairs

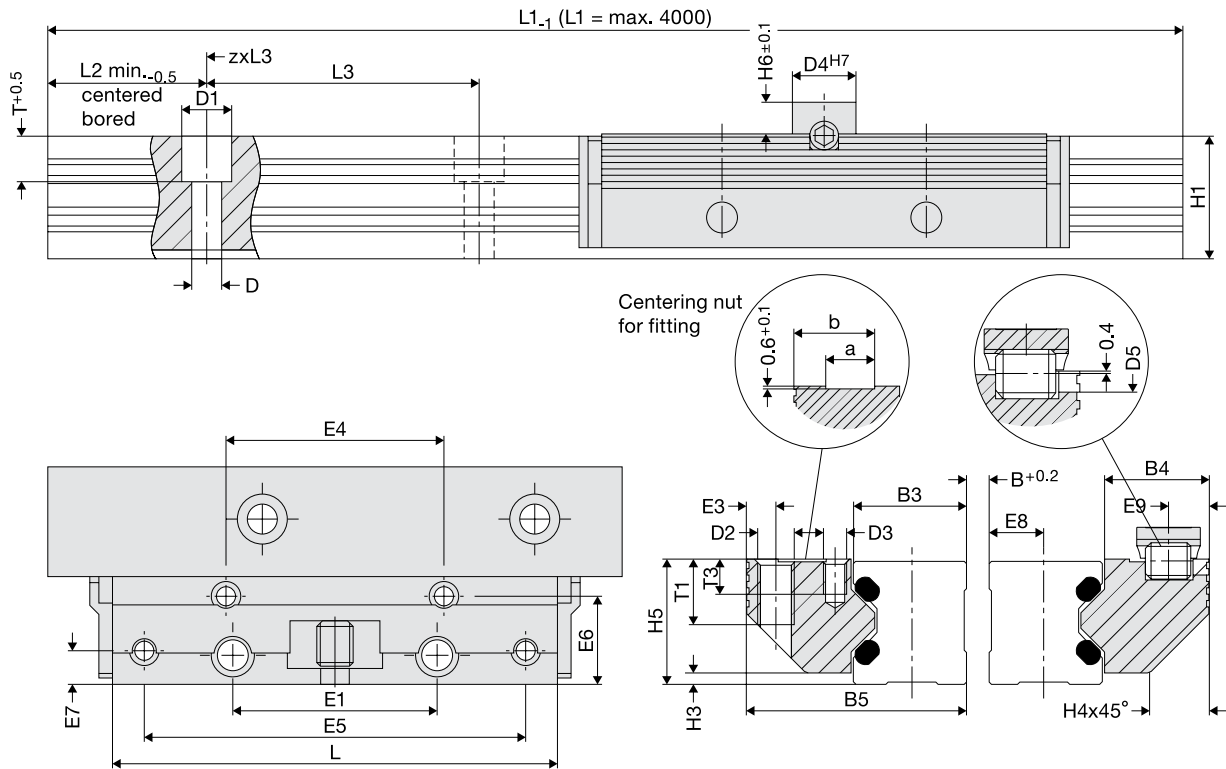

## Dimensions

Size	Dimensions																		
	B5	H5	B3	B4	D3	D4	D5	E3	E4	E5	E6	E7	E8	E9	H6	T3	a	b	
12	24.4	15.0	12.00	11.9	M3	8	3	3.4	29	57	9.7	3.4	5.5	4.9	4	6.0	4.5	9.5	
15	30.9	19.0	15.25	15.2	M4	10	4	4.4	34	68	12.4	4.9	7.0	5.9	5	7.5	5.0	12.5	
20	40.9	23.0	20.00	20.4	M5	10	4	4.9	42	80	16.9	5.9	9.5	5.9	5	8.0	7.5	16.0	
25	48.4	27.5	25.00	22.9	M5	14	6	6.4	48	84	19.4	7.4	12.0	8.9	7	5.0	10.5	17.5	
35	68.9	37.5	35.00	32.9	M6	14	6	8.9	67	117	28.4	8.9	17.0	8.9	7	7.5	12.5	26.0	
45	82.4	46.5	45.00	36.4	M8	14	6	9.9	83	146	30.9	9.9	22.0	8.9	7	9.5	15.5	31.0	

## Load ratings, weight

Size	Load ratings		Moment load ratings* RSP					Weight	
	N	Co	Nm		Nm		RSP	kg	
	C	Co	Mocx	Mcx	Mocy/Mocx	Mcy/Mcz	RSP	rail/m	
12	350	400	0.20(B+ 30.3)	0.20(B+ 30.3)		6	5	0.07	0.4
15	600	700	0.35(B+ 36.5)	0.30(B+ 36.5)		12	10	0.12	0.8
20	700	900	0.40(B+ 47.0)	0.33(B+ 47.0)		17	14	0.23	1.0
25	1200	1600	0.80(B+ 58.4)	0.60(B+ 58.4)		35	25	0.34	1.9
35	2000	2500	1.20(B+ 85.0)	0.90(B+ 85.0)		76	58	0.99	3.5
45	4400	5500	2.70(B+109.0)	2.20(B+109.0)		210	170	1.79	5.6

\*There is more information on moment load ratings on page 110/111.

## Order numbers

Order no.	Order key
RSP	Single rail pair
84495T	e.g. <b>FDA25E1500</b> 
84395T	
84442T	
84367T	
84368T	
84369T	

\*\*Guide rails up to 4000 mm on one piece. Longer strokes are coupled.

Aluminium Roller Guide  
Non-corrosive low cost

### Cassette + double rail

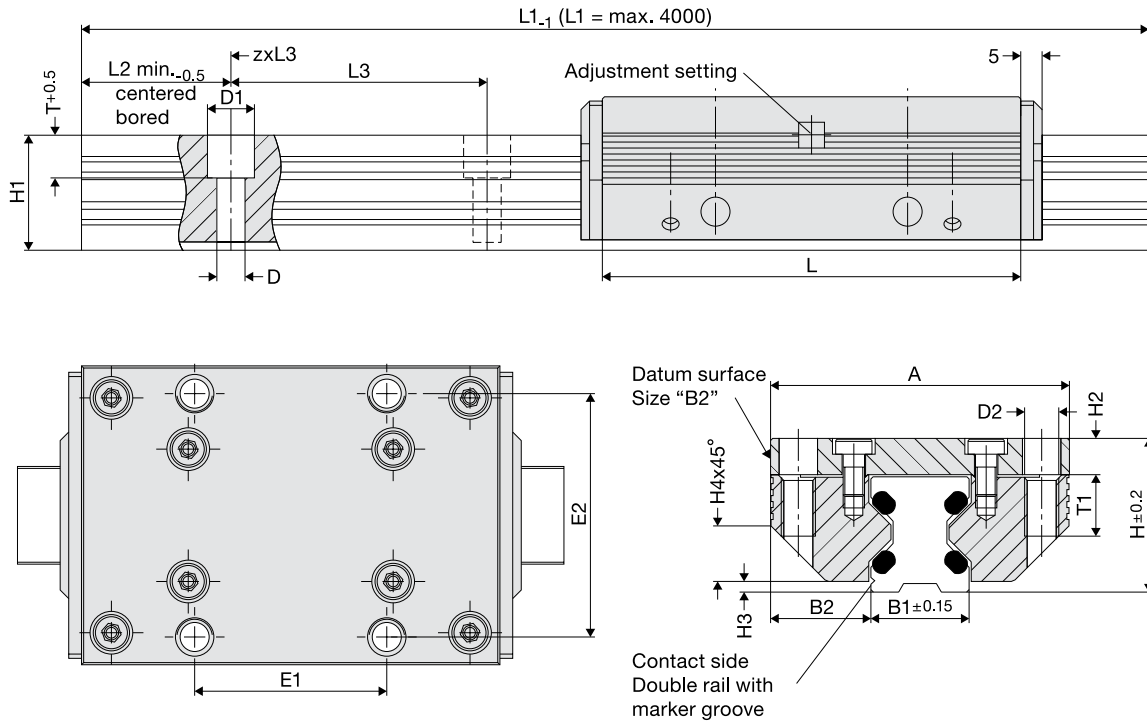

### Dimensions

Size	Dimensions																	
	A	L	H	B1	B2	D	D1	D2	E1	E2	H1	H2	H3	H4	L2	L3	T	T1
12	37	64	19	12.0	12.50	3.4	6	M 4	25	30	14.7	4.0	1.4	5.5	10	40	5.5	8
15	47	78	24	15.5	15.75	4.5	8	M 5	30	38	18.7	5.0	2.0	8.0	10	60	6.0	10
20	63	92	30	21.0	21.00	5.5	10	M 6	40	53	22.6	7.0	2.0	11.0	10	60	8.0	12
25	70	98	36	23.0	23.50	6.6	11	M 8	45	57	27.0	8.5	2.5	13.0	10	60	10.0	16
35	100	135	48	32.0	34.00	9.0	15	M10	62	82	37.0	10.5	3.5	20.0	12	80	11.5	20
45	120	165	60	45.0	37.50	11.0	18	M12	80	100	46.0	13.5	4.0	22.0	16	105	14.5	24

### Load ratings, weight

Size	Load ratings		Moment load ratings* cassette				Weight	
	N	N	Nm				kg	kg
	C	Co	Mocx	Mcx	Mocy/Mocz	Mcy/Mcz	Cassette	rail/m
12	620	170	1.6	5.7	2.4	8.9	0.1	0.4
15	700	230	2.5	7.5	4.0	12.0	0.2	0.8
20	940	300	4.0	13.0	6.0	19.0	0.4	0.9
25	1500	700	11.0	23.0	15.0	32.0	0.5	1.8
35	3100	1400	32.0	72.0	42.0	95.0	1.4	3.2
45	6300	2700	86.0	200.0	103.0	238.0	2.5	5.5

### Order numbers

Order no.	Order key
Cassette	Double rail
84494LN	e.g. <b>FDC25D1500</b> 
84396LN	
84441LN	
84363LN	
84364LN	
84365LN	Size

\*There is more information on moment load ratings on page 110/111.

\*\*Guide rails up to 4000 mm on one piece. Longer strokes are coupled.



## Materials

	Body material	Rollers	Wipers
<b>Standard</b>	High-strength, anodized aluminium	Antifriction bearing steel	Plastic plate with felt wiper

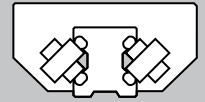

## Pair of roller shoes + single rail pairs

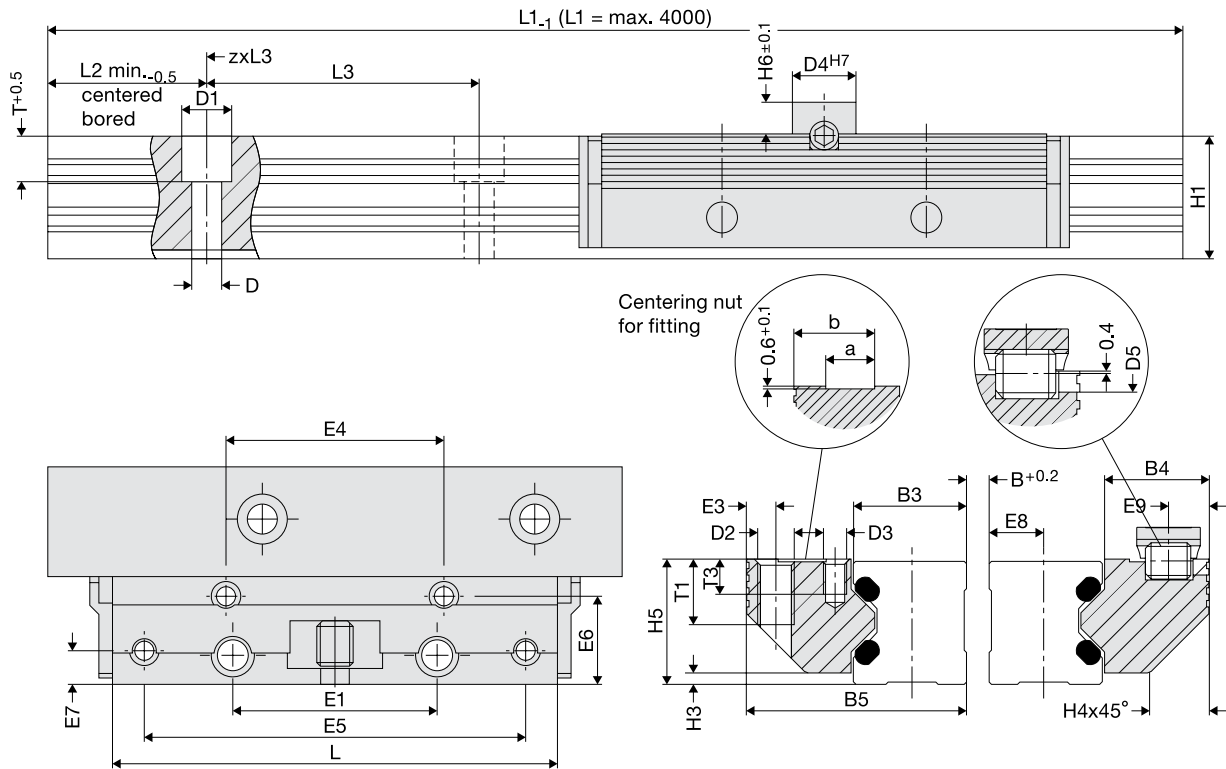

## Dimensions

Size	Dimensions																		
	B5	H5	B3	B4	D3	D4	D5	E3	E4	E5	E6	E7	E8	E9	H6	T3	a	b	
12	24.4	15.0	12.00	11.9	M3	8	3	3.4	29	57	9.7	3.4	5.5	4.9	4	6.0	4.5	9.5	
15	30.9	19.0	15.25	15.2	M4	10	4	4.4	34	68	12.4	4.9	7.0	5.9	5	7.5	5.0	12.5	
20	40.9	23.0	20.00	20.4	M5	10	4	4.9	42	80	16.9	5.9	9.5	5.9	5	8.0	7.5	16.0	
25	48.4	27.5	25.00	22.9	M5	14	6	6.4	48	84	19.4	7.4	12.0	8.9	7	5.0	10.5	17.5	
35	68.9	37.5	35.00	32.9	M6	14	6	8.9	67	117	28.4	8.9	17.0	8.9	7	7.5	12.5	26.0	
45	82.4	46.5	45.00	36.4	M8	14	6	9.9	83	146	30.9	9.9	22.0	8.9	7	9.5	15.5	31.0	

## Load ratings, weight

Size	Load ratings		Moment load ratings* RSP					Weight	
	N	Co	Nm		Nm		RSP	kg	
	C	Co	Mocx	Mcx	Mocy/Mocz	Mcy/Mcz	RSP	rail/m	
12	620	170	0.08(B+ 30.3)	0.30(B+ 30.3)	2.4	8.9	0.07	0.4	
15	700	230	0.10(B+ 36.5)	0.35(B+ 36.5)	4.0	12.0	0.12	0.8	
20	940	300	0.15(B+ 47.0)	0.50(B+ 47.0)	6.0	19.0	0.23	1.0	
25	1500	700	0.35(B+ 58.4)	0.70(B+ 58.4)	15.0	32.0	0.34	1.9	
35	3100	1400	0.70(B+ 85.0)	1.50(B+ 85.0)	42.0	95.0	0.99	3.5	
45	6300	2700	1.40(B+109.0)	3.10(B+109.0)	103.0	238.0	1.79	5.6	

\*There is more information on moment load ratings on page 110/111.

## Order numbers

Order no.	Order key
RSP	Single rail pair

e.g. **FDC25E1500**

Single rail

Size

\*\*Guide rails up to 4000 mm on one piece. Longer strokes are coupled.

### Cassette + double rail

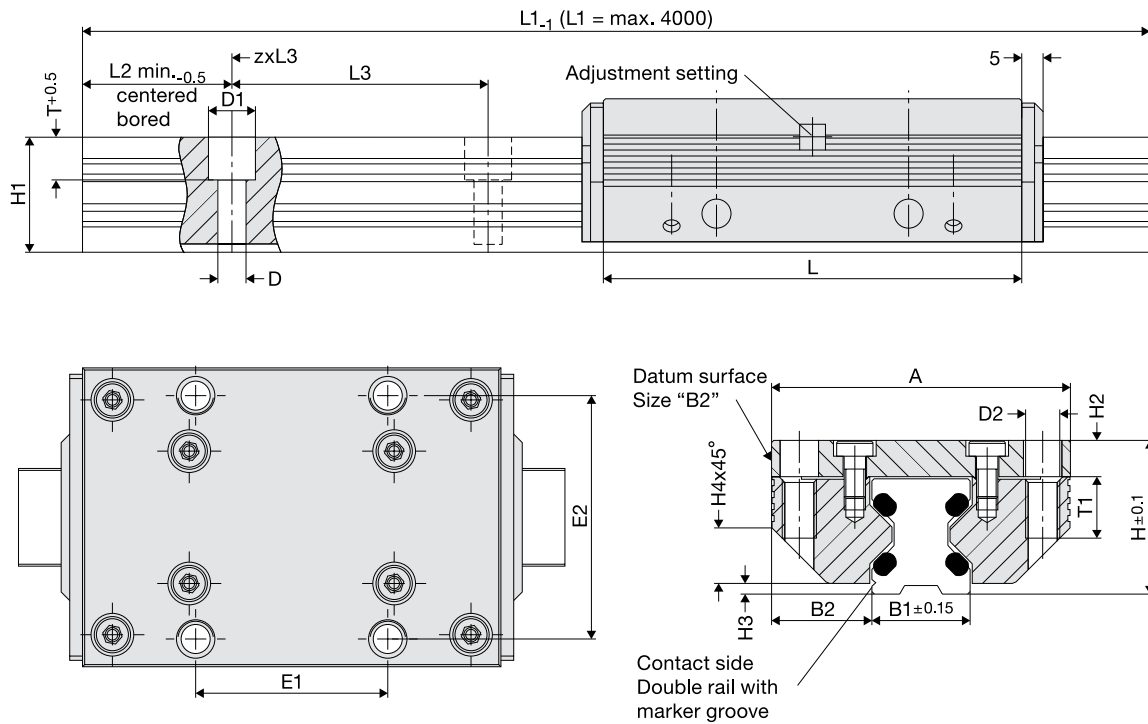

### Dimensions

Size	Dimensions																	
	A	L	H	B1	B2	D	D1	D2	E1	E2	H1	H2	H3	H4	L2	L3	T	T1
25	70	98	36	23.0	23.50	6.6	11	M 8	45	57	27.0	8.5	2.5	13.0	10	60	10.0	16
35	100	135	48	32.0	34.00	9.0	15	M10	62	82	37.0	10.5	3.5	20.0	12	80	11.5	20
45	120	165	60	45.0	37.50	11.0	18	M12	80	100	46.0	13.5	4.0	22.0	16	105	14.5	24

### Load ratings, weight

Size	Load ratings		Moment load ratings* cassette				Weight	
	N	Co	Mocx	Mcx	Mocy/Mocz	Mcy/Mcz	Cassette	kg rail/m
25	7500	3700	58	118	81	165	0.5	1.8
35	13400	8100	189	315	250	416	1.4	3.2
45	24300	14400	461	777	548	924	2.5	5.5

### Order numbers

Order no.	Order key
84363S	Cassette Double rail
84364S	
84365S	

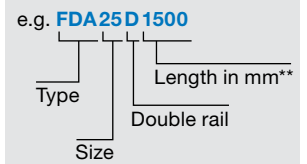

\*There is more information on moment load ratings on page 110/111.

\*\*Guide rails up to 4000 mm on one piece. Longer strokes are coupled.

## Materials

	Body material	Rollers	Wipers
<b>Standard</b>	High-strength, anodized aluminium	Antifriction bearing steel	Plastic plate with felt wiper

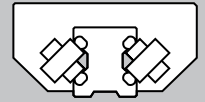

## Pair of roller shoes + single rail pairs

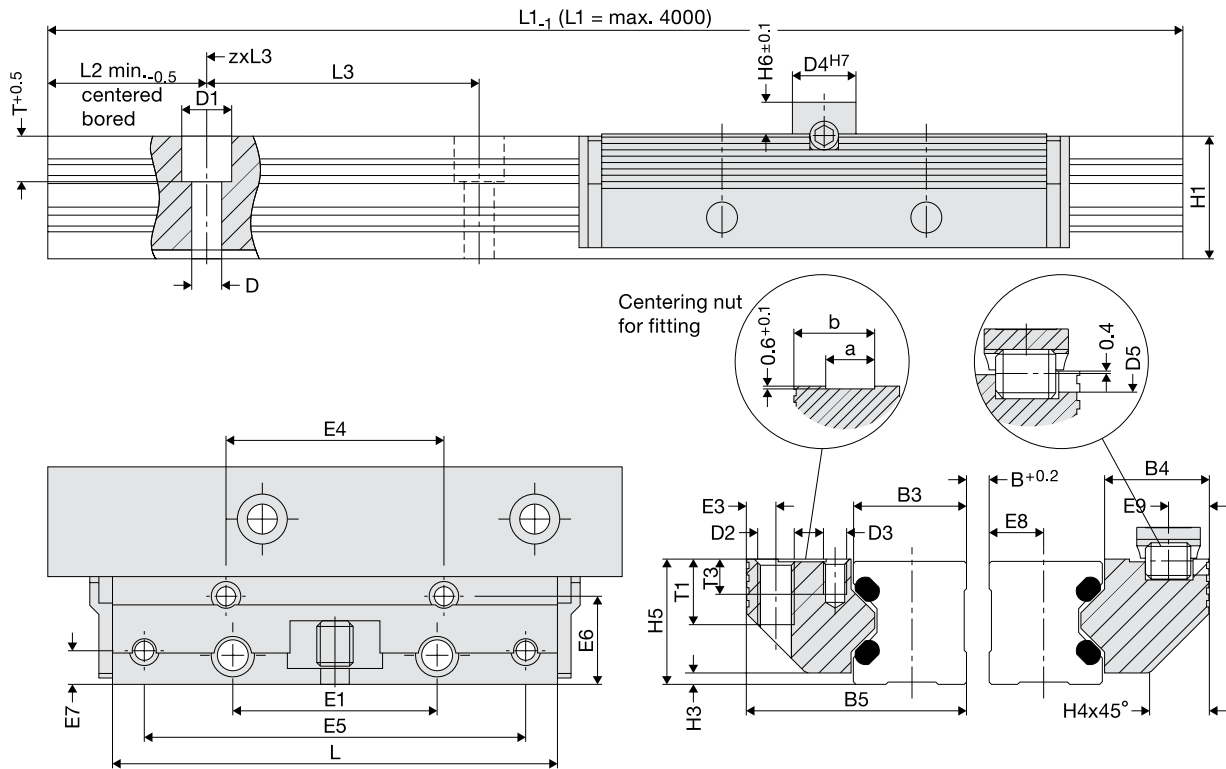

## Dimensions

Size	Dimensions																	
	B5	H5	B3	B4	D3	D4	D5	E3	E4	E5	E6	E7	E8	E9	H6	T3	a	b
25	48.4	27.5	25.00	22.9	M5	14	6	6.4	48	84	19.4	7.4	12.0	8.9	7	5.0	10.5	17.5
35	68.9	37.5	35.00	32.9	M6	14	6	8.9	67	117	28.4	8.9	17.0	8.9	7	7.5	12.5	26.0
45	82.4	46.5	45.00	36.4	M8	14	6	9.9	83	146	30.9	9.9	22.0	8.9	7	9.5	15.5	31.0

## Load ratings, weight

Size	Load ratings		Moment load ratings* RSP				Weight	
	N	Co	Nm		RSP		kg	
	C	Co	Mocx	Mcx	Mocy/Mocz	Mcy/Mcz	RSP	rail/m
25	7500	3700	1.8(B+ 58.4)	3.7(B+ 58.4)	81	165	0.34	1.9
35	13400	8100	4.0(B+ 85.0)	6.7(B+ 85.0)	250	416	0.99	3.5
45	24300	14400	7.2(B+109.0)	12.2(B+109.0)	548	924	1.79	5.6

## Order numbers

Order no.	Order key
RSP	Single rail pair

e.g. **FDA25E1500**

\*There is more information on moment load ratings on page 110/111.

\*\*Guide rails up to 4000 mm on one piece. Longer strokes are coupled.

## Cassette + double rail

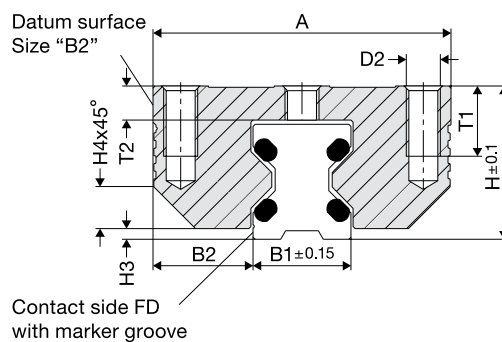
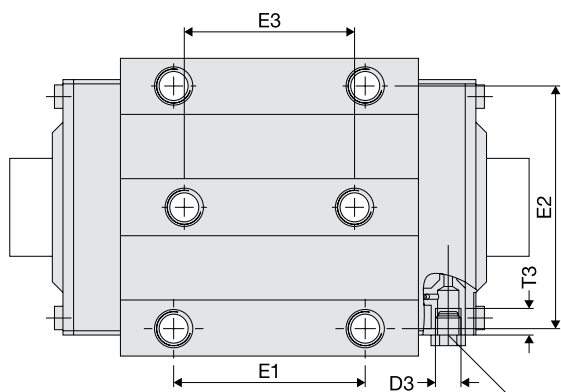
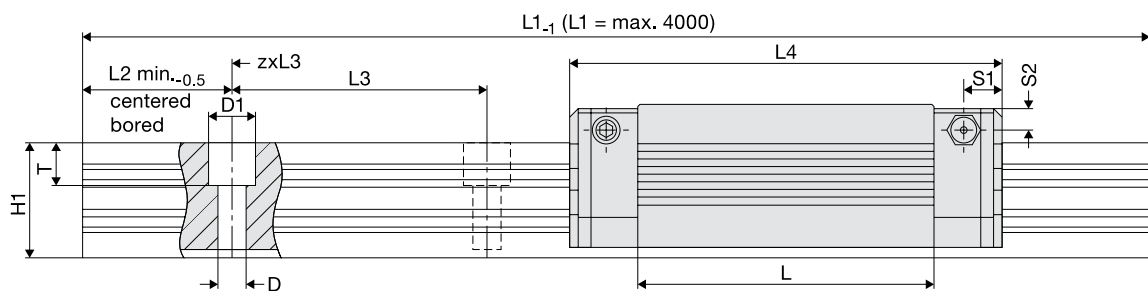

1x Funnel-type lubricating nipple  
DIN 3405-D1-M6x1

## Materials

	Body material	Rollers	Wipers
<b>Standard</b>	High-strength, anodized aluminium	Antifriction bearing steel	Plastic plate with TEEE wipers

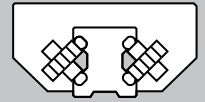

## Dimensions

Size	Dimensions																							
	mm																							
	A	L	H	B1	B2	D	D1	D2	D3	E1	E2	E3	H1	H3	H4	L2	L3	L4	T	T1	T2	T3	S1	S2
25	70	70	36	23	23.5	6.6	11	M8	M6	45	57	40	27	2.5	10	10	60	102	10	16	8	6	9	6

## Load ratings, weight

Size	Load ratings		Moment load ratings* cassette				Weight	
	N		Nm				kg	
	C	Co	Mocx	Mcx	Mocy/Mocz	Mcy/Mcz	Cassette	rail/m
25	23400	25000	392	368	245	230	0.39	1.8

## Order numbers

Order no.	Order key
Cassette	Double rail
<b>84042A</b>	e.g. <b>FDA25D1500</b>

\*There is more information on moment load ratings on page 110/111.

\*\*Guide rails up to 4000 mm on one piece. Longer strokes are coupled.

### Recirculating element + single rail

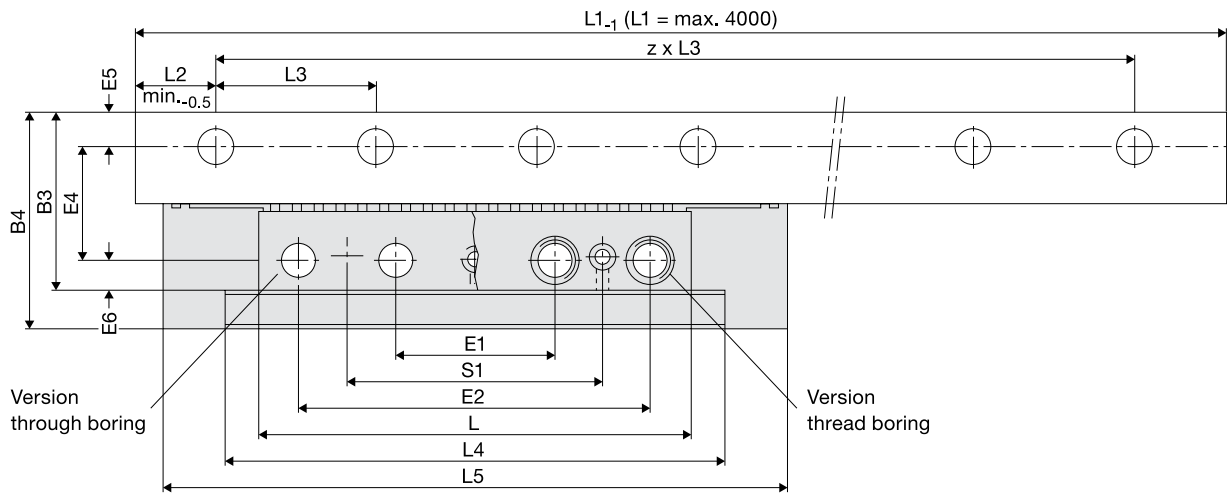

Type FRA06E / FRA08E

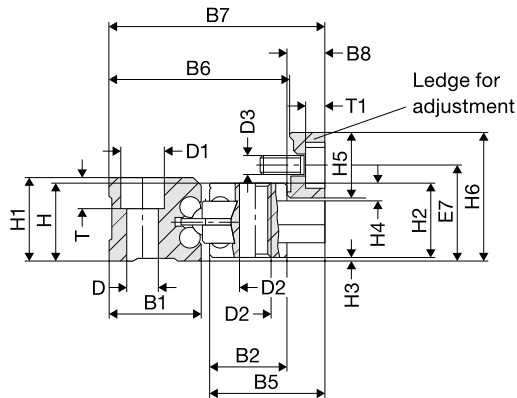

Type FRA10E / FRA13E

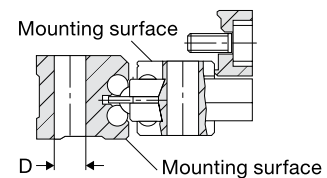

### Lubrication borings

FRA06U / FRA08U  
with through boring

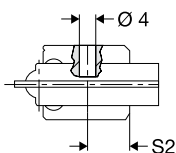

FRA10U / FRA13U  
with through boring

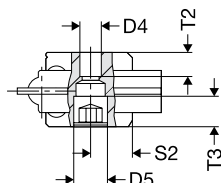

FRA06U / FRA13U  
with thread boring

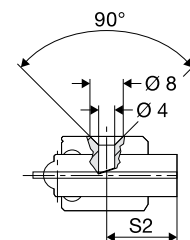

## Materials

	Body material	Balls	Wipers
<b>Standard</b>	High-strength, anodized aluminium Steel Zinc diecasting	Antifriction bearing steel	Integrated felt wiper

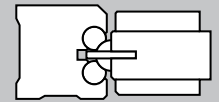

## Dimensions single rail

Size	Dimensions																
	mm																
	H	B1	B3	B4	B6	B7	D	D1	E4	E5	E7	H1	H3	H6	L2	L3	T
FRA06E	16.0	20.0	36.5	44.5	38.0	44.5	5.5	10	24.5	7.0	20.7	16.7	1.0	27.7	25	50	7.0
FRA08E	21.0	26.3	47.3	57.3	48.8	57.3	6.6	11	31.8	8.5	26.0	22.2	1.0	32.5	50	100	8.5
FRA10E	23.8	24.4	51.4	63.0	51.4	62.9	9.0	-	31.4	10.0	29.4	25.0	1.0	39.4	50	100	-
FRA13E	31.2	31.6	65.1	89.5	65.1	80.1	12.0	-	41.1	12.0	37.2	33.0	1.2	48.7	50	100	-

## Dimensions recirculating element

Size	Dimensions																				
	mm																				
	B2	B5	B8	D2	D3	D4	D5	E1	E2	E6	H2	H4	H5	L	L4	L5	S1	S2	T1	T2	T3
FRA06UD	15.0	23.1	8.0	6.0	M05	-	-	25	70	5	15.0	3.0	14.0	82.0	82	124	-	5.0	4.0	-	-
FRA06UM	15.0	23.1	8.0	M06	M05	-	-	25	70	5	15.0	3.0	14.0	82.0	82	124	50	7.0	4.0	-	-
FRA08UD	19.5	29.5	10.0	6.6	M06	-	-	32	84	7	20.0	5.0	15.5	100.0	104	153	-	7.0	4.8	-	-
FRA08UM	19.5	29.5	10.0	M08	M06	-	-	32	84	7	20.0	5.0	15.5	100.0	104	153	58	9.5	4.8	-	-
FRA10UD	24.4	36.0	11.5	9.0	M06	M06	M06	50	110	10	22.8	5.4	20.0	134.2	155	194	-	10.0	6.0	9.0	9.0
FRA10UM	24.4	36.0	11.5	M10	M06	-	-	50	110	10	22.8	5.4	20.0	134.2	155	194	80	11.0	6.0	-	-
FRA13UD	31.6	56.0	15.0	11.0	M08	M05	G1/8	60	140	12	30.0	7.6	23.0	169.0	178	242	-	12.0	8.0	8.0	12.0
FRA13UM	31.6	56.0	15.0	M12	M08	-	-	60	140	12	30.0	7.6	23.0	169.0	178	242	100	15.0	8.0	-	-

## Load ratings, weight

Size	Load ratings		Weight		
	N	Co	kg		
	C	Co	Recirculating element/unit	rail/m	
FRA06UD	24200	37300	0.2	0.7	with through boring
FRA06UM	24200	37300	0.2	0.7	with thread boring
FRA08UD	38200	58300	0.4	1.2	with through boring
FRA08UM	38200	58300	0.4	1.2	with thread boring
FRA10UD	62000	85400	0.8	1.9	with through boring
FRA10UM	62000	85400	0.8	1.9	with thread boring
FRA13UD	103100	137700	1.7	2.9	with through boring
FRA13UM	103100	137700	1.7	2.9	with thread boring

## Order numbers

Order no.	Order key
Recircl. element	Single rail
<b>80587A</b>	<p>e.g. <b>FRA06E1500</b>  Type      Length in mm**  Single rail  Size</p>
<b>80545A</b>	
<b>80588A</b>	
<b>80546A</b>	
<b>80589A</b>	
<b>80547A</b>	
<b>80590A</b>	
<b>80548A</b>	

\*\*Guide rails up to 4000 mm on one piece. Longer strokes are coupled.

# Linear Tables

Type FTB

## FTB06A / FTB06B

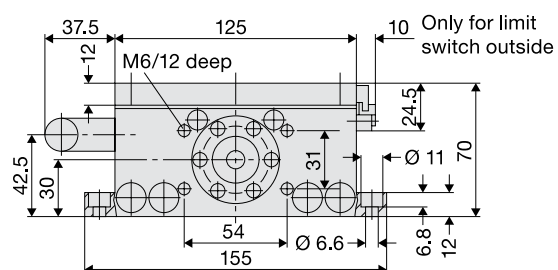
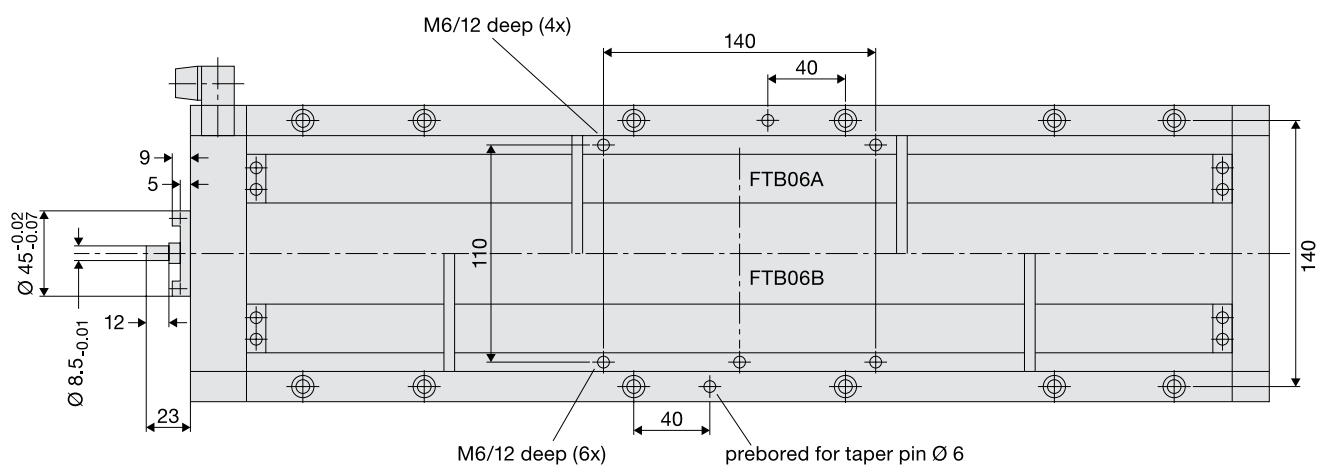
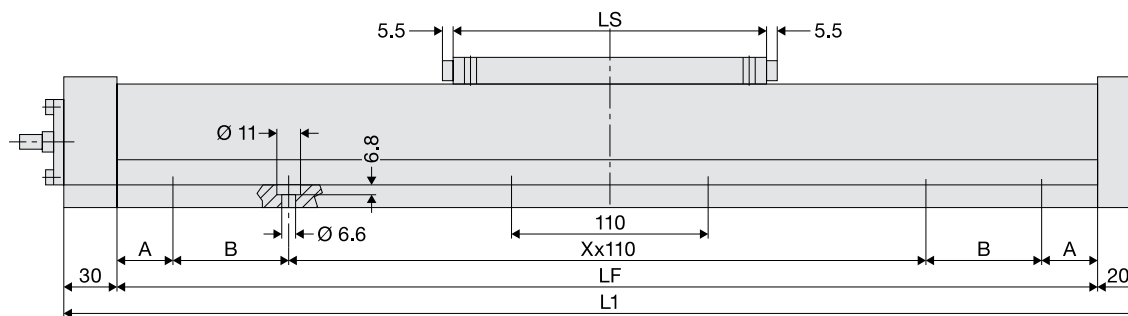



## Materials

	Body material	Balls	Wipers
<b>Standard</b>	High-strength, anodized aluminium	Antifriction bearing steel 100Cr6	Plastic plate with felt wiper
<b>Special</b>		Non-corrosive steel X12CrNi177	

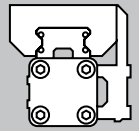

## Dimensions

Stroke	Load rating N C	Torque		Dimensions						Spindle		Traverse speed		Spindle rotary speed		Fixing screws Number x size	Weight kg	Order no.	
		Mcx	Mcy, Mcz	A	B	LS	LF	L1	X x 110	Ø	pitch	Stand.	Max.	Stand.	Max.				
<b>FTB06A</b>																			
100	15000	670	220	30.0	72.5	165	315	365	1 x 110	16	5	8	15	1600	3000	8xM6	6.4	<a href="#">92621A</a>	
200	15000	670	220	42.5		165	415	465	3 x 110	16	5	8	15	1600	3000	8xM6	7.5	<a href="#">92622A</a>	
300	15000	670	220	92.5		165	515	565	3 x 110	16	5	8	15	1600	3000	8xM6	8.6	<a href="#">92623A</a>	
400	15000	670	220	32.5		165	615	665	5 x 110	16	5	8	15	1600	3000	12xM6	9.7	<a href="#">92624A</a>	
500	15000	670	220	82.5		165	715	765	5 x 110	16	5	8	15	1600	3000	12xM6	10.8	<a href="#">92625A</a>	
700	15000	670	220	72.5		165	915	965	7 x 110	16	5	6	14	1200	2800	16xM6	13.0	<a href="#">92626A</a>	
1000	15000	670	220	30.0	82.5	165	1215	1265	9 x 110	16	10	12	25	1200	2500	24xM6	16.3	<a href="#">92627A</a>	
1200	15000	670	220	30.0	72.5	165	1415	1465	11 x 110	16	10	8	12	800	1200	28xM6	18.5	<a href="#">92628A</a>	
1500	15000	670	220	32.5		165	1715	1765	15 x 110	16	10	6	8	600	800	32xM6	21.8	<a href="#">92629A</a>	

### FTB06B

100	30000	1380	1930	50		280	430	480	3 x 110	16	5	8	15	1600	3000	8xM6	7.5	<a href="#">92630A</a>
200	30000	1380	1930	100		280	530	580	3 x 110	16	5	8	15	1600	3000	8xM6	8.6	<a href="#">92631A</a>
300	30000	1380	1930	40		280	630	680	5 x 110	16	5	8	15	1600	3000	12xM6	9.7	<a href="#">92632A</a>
400	30000	1380	1930	90		280	730	780	5 x 110	16	5	8	15	1600	3000	12xM6	10.8	<a href="#">92633A</a>
500	30000	1380	1930	30		280	830	880	7 x 110	16	5	8	15	1600	3000	16xM6	11.9	<a href="#">92634A</a>
700	30000	1380	1930	20		280	1030	1080	9 x 110	16	5	6	14	1200	2800	20xM6	14.1	<a href="#">92635A</a>
1000	30000	1380	1930	60		280	1330	1380	11 x 110	16	10	12	25	1200	2500	24xM6	17.4	<a href="#">92636A</a>
1200	30000	1380	1930	50		280	1530	1580	13 x 110	16	10	8	12	800	1200	28xM6	19.6	<a href="#">92637A</a>
1500	30000	1380	1930	30		280	1830	1880	15 x 110	16	10	6	8	600	800	32xM6	22.9	<a href="#">92638A</a>

# Linear Modules

Type FTC

## FTC 15-25

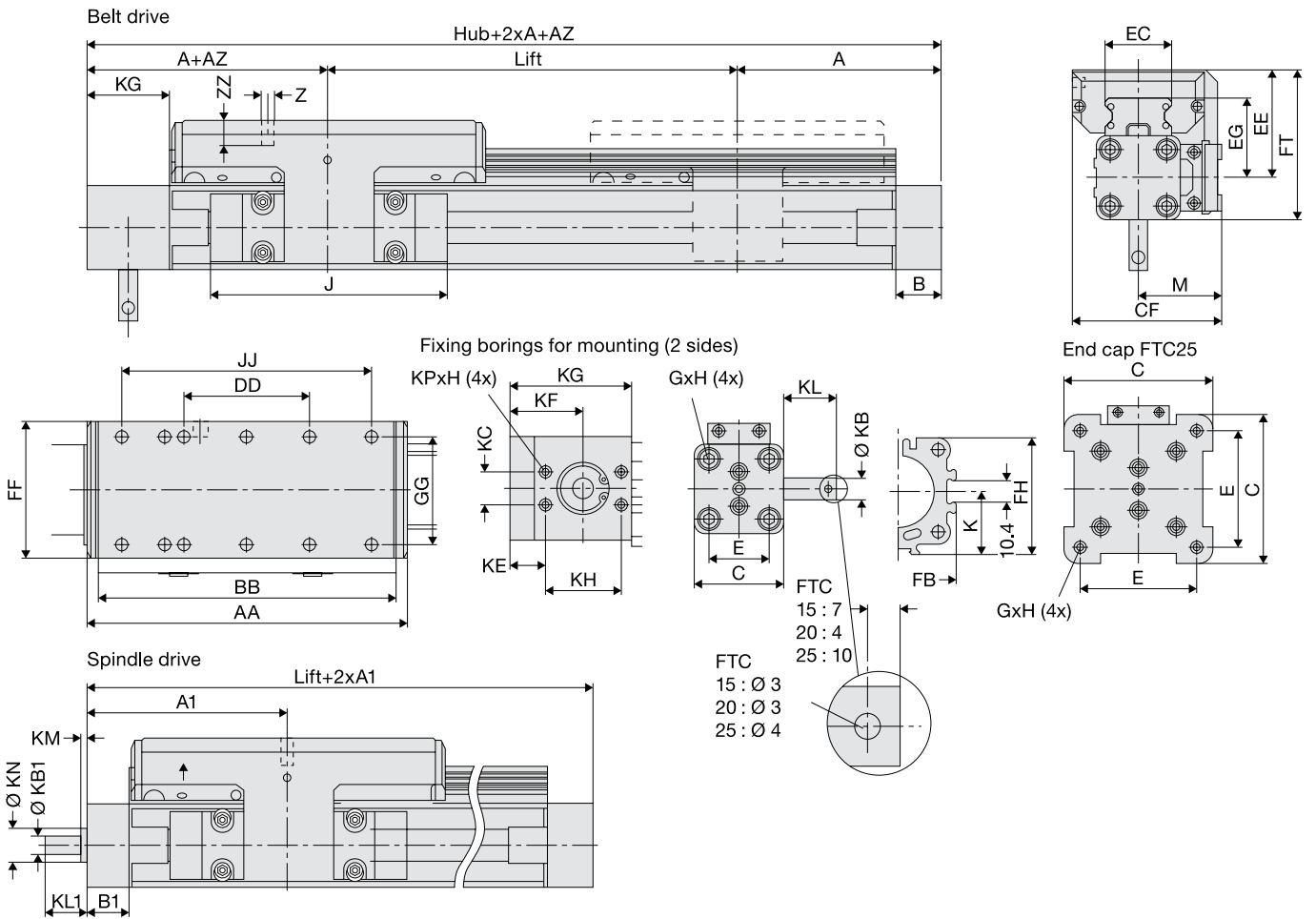

## Dimensions

Size	Dimensions												
	A	A1	B	B1	C	E	G	H	J	K	M	Z	
15	125	100	22	22.0	41	27	M5	10	117	21.5	40.5	M6	
20	150	125	25	25.5	52	36	M6	12	152	28.5	49.0	M6	
25	200	175	25	33.0	87	70	M6	12	200	43.0	62.0	M6	

Size	Dimensions																										
	AA	AZ	BB	DD	CF	EC	EE	EG	FB	FF	FH	FT	GG	JJ	KB	KB1	KC	KE	KF	KG	KH	KL	KL1	KM	KN	KP	ZZ
15	154	10	144	60	72.5	32.5	53	39	40	64	39.5	73.5	50	120	10j6	6	15	22.0	37.0	57	30	24	17	2	13	M5	12
20	197	11	187	80	91.0	42.0	62	48	52	84	51.7	88.0	64	160	10j6	10	18	17.5	36.5	61	38	26	31	2	20	M6	12
25	276	24	266	120	117.0	63.0	75	57	76	110	77.0	118.5	90	240	16j6	15	32	23.5	48.5	85	50	34	43	3	28	M8	16

## Materials

	Body material	Balls	Wipers
<b>Standard</b>	High-strength, anodized aluminium	Antifriction bearing steel 100Cr6	Plastic plate with felt wiper
<b>Special</b>		Non-corrosive steel X12CrNi177	

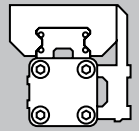

Stroke mm	Order no.					
	FTC 15		FTC 20		FTC 25	
	with: Toothed belt	Spindle	Toothed belt	Spindle	Toothed belt	Spindle
100	92700A	92700S	92734A	92734S	92768A	92768S
200	92701A	92701S	92735A	92735S	92769A	92769S
300	92702A	92702S	92736A	92736S	92770A	92770S
400	92703A	92703S	92737A	92737S	92771A	92771S
500	92704A	92704S	92738A	92738S	92772A	92772S
600	92705A	92705S	92739A	92739S	92773A	92773S
700	92706A	92706S	92740A	92740S	92774A	92774S
800	92707A	92707S	92741A	92741S	92775A	92775S
900	92708A	92708S	92742A	92742S	92776A	92776S
1000	92709A	92709S	92743A	92743S	92777A	92777S
1100	92710A	92710S	92744A	92744S	92778A	92778S
1200	92711A		92745A	92745S	92779A	92779S
1300	92712A		92746A	92746S	92780A	92780S
1400	92713A		92747A	92747S	92781A	92781S
1500	92714A		92748A	92748S	92782A	92782S
1600	92715A		92749A	92749S	92783A	92783S
1700	92716A		92750A	92750S	92784A	92784S
1800	92717A		92751A	92751S	92785A	92785S
1900	92718A		92752A	92752S	92786A	92786S
2000	92719A		92753A	92753S	92787A	92787S
2200	92721A		92755A		92789A	92789S
2400	92723A		92757A		92791A	92791S
2600	92725A		92759A		92793A	92793S
2800	92727A		92761A		92795A	92795S
3000	92729A		92763A		92797A	92797S
3200	92731A		92765A		92799A	92799S
3400	92733A		92767A			

## Performance overview

Load rating: stat. / dyn. Co / C	N	3400/4200		5400/5400		15100/13500	
Max. torque (MCX / MCY, MCZ)	Nm	81/190		133/338		483/922	
Max. speed	m/s	2	0.25	3	0.25/0.5	5	0.25/0.5/1.25/2.5
Linear route per motor revolution	mm	60	5	60	5/10	100	5/10/25
Mass: basic weight/per m stroke/moved	kg	1.8/0.43/0.75	1.9/0.36/0.75	3.7/0.7/1.18	3.6/0.59/1.18	8.2/1.32/2.5	8.8/1.01/2.5
Max. rotary speed of the drive axle	min <sup>-1</sup>	2000		3000		3000	
Max. effective power FX < 1 m/s	N	55	250	150	600	425	1500
at speed 1-2 m/s	N	50	250	120	600	375	1500
at speed > 2 m/s	N			100		300	
Basic torque (without load)	Nm	0.4	0.2	0.2	0.2/0.3	0.6	0.3/0.4/0.5
Max. permissible drive torque < 1 m/s	Nm	0.9		2.3	1.5/2.8	10	4.2/7.5/20
at speed 1-2 m/s	Nm	0.9	0.6	2		9.5	
at speed > 2 m/s	Nm			1.8		7.5	
Max. acceleration/deceleration	m/s <sup>2</sup>	10	10	10	10	10	10
Repeat accuracy	mm/m	±0.05		±0.05		±0.05	
Positioning accuracy*	mm/m	±0.15		±0.15		±0.15	
Run accuracy	mm	±0.03/300		±0.03/300		±0.03/300	

\*depends on various factors

# Linear Modules

Type FTD

## FTD 15-35

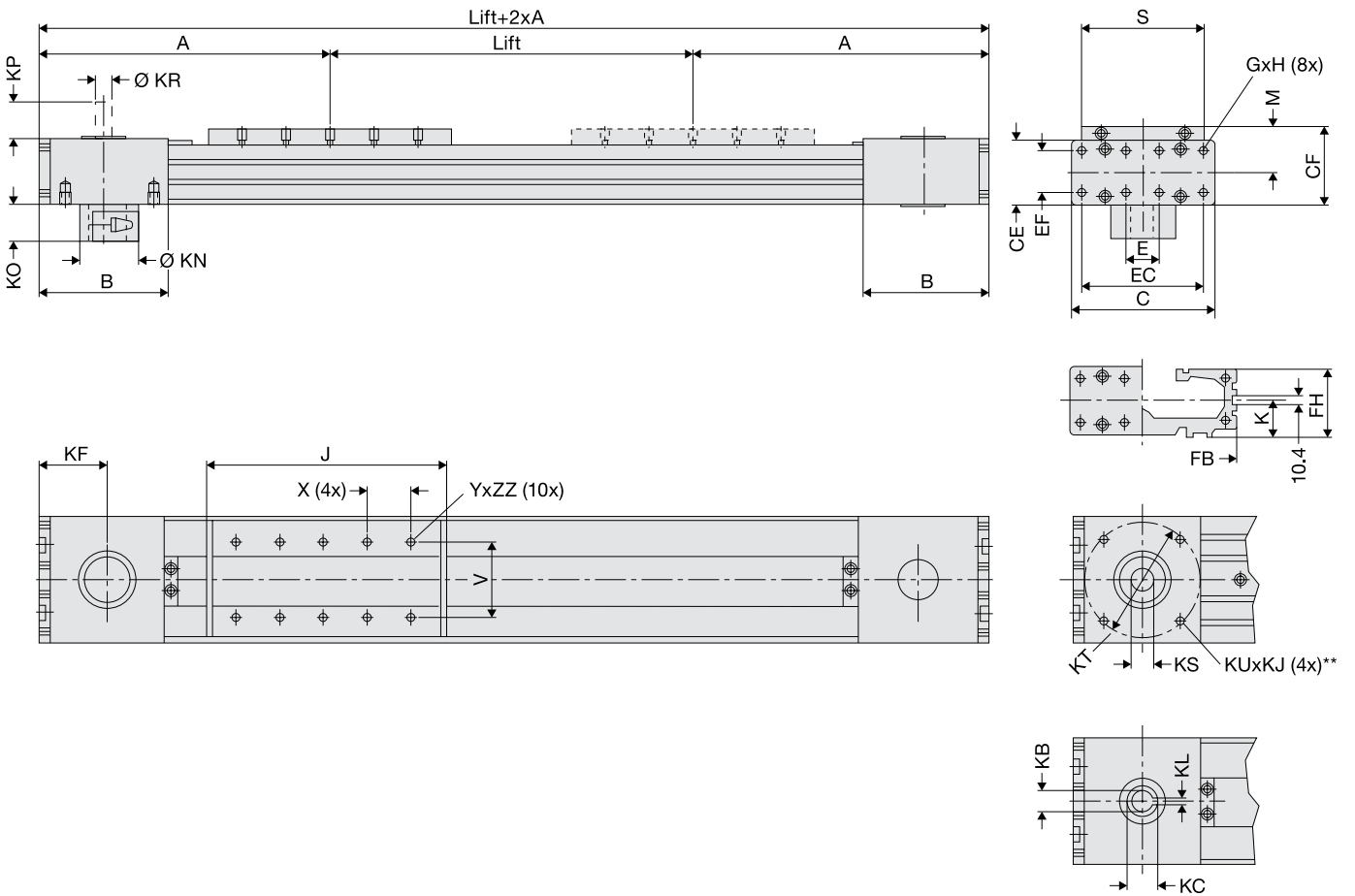

Optional: Sleeve shaft with feather key groove

## Dimensions

Size	Dimensions												
	mm												
	A	B	C	E	G	H	J	K	M	S	V	X	Y
15	218	88	93	25	M5	10	178	21.5	31	85	64	40	M6
20	262	112	116	28	M6	12	218	28.5	38	100	64	40	M6
35	347	147	175	18	M6	12	263	43.0	49	124	90	60	M6

Size	Dimensions																		
	mm																		
	CE	CF	EC	EF	FB	FH	KF	KB*	KC	KL	KJ	KN	KO	KP	KR	KS*	KT	KU	ZZ
15	42	52.5	79	27	92	39.5	49.0	16 <sup>H7</sup>	18.3	5	8	34	21.7	30	16 <sup>H7</sup>	16 <sup>H7</sup>	82	M 8	8
20	56	66.5	100	36	116	51.7	62.0	22 <sup>H7</sup>	24.8	6	12	53	30.0	30	22 <sup>H7</sup>	22 <sup>H7</sup>	106	M10	10
35	87	92.5	158	70	164	77.0	79.5	32 <sup>H7</sup>	35.3	10	19	75	41.0	35	32 <sup>H7</sup>	32 <sup>H7</sup>	144	M12	10

## Materials

	Body material	Balls	Wipers
<b>Standard</b>	High-strength, anodized aluminium	Antifriction bearing steel 100Cr6	Plastic plate with felt wiper
<b>Special</b>		Non-corrosive steel X12CrNi177	

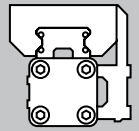

Stroke mm	Order no.		
	FTD 15 without motorisation	FTD 20 without motorisation	FTD 35 without motorisation
100	92900A	92925A	92950A
200	92901A	92926A	92951A
300	92902A	92927A	92952A
400	92903A	92928A	92953A
500	92904A	92929A	92954A
600	92905A	92930A	92955A
700	92906A	92931A	92956A
800	92907A	92932A	92957A
900	92908A	92933A	92958A
1000	92909A	92934A	92959A
1200	92910A	92935A	92960A
1400	92911A	92936A	92961A
1600	92912A	92937A	92962A
1800	92913A	92938A	92963A
2000	92914A	92939A	92964A
2500	92915A	92940A	92965A
3000	92916A	92941A	92966A
3500	92917A	92942A	92967A
4000	92918A	92943A	92968A
4500	92919A	92944A	92969A
5000	92920A	92945A	92970A
5500	92921A	92946A	92971A
6000	92922A	92947A	92972A
6500	92923A	92948A	92973A
7000	92924A	92949A	92974A

## Performance overview

Load rating: stat. / dyn. Co / C	N	3400/4200	5400/5400	18000/12500
Max. torque (MCX / MCY, MCZ)	Nm	45/274	76/460	294/1233
Max. speed	m/s	10	10	10
Max. acceleration/deceleration	m/s <sup>2</sup>	40	40	40
Max. effective power FX < 1 m/s	N	1070	1870	3120
at speed 1-3 m/s	N	890	1560	2660
at speed > 3 m/s	N	550	1030	1940
Basic torque (without load)	Nm	1.2	2.2	3.2
Mass: basic weight/per m stroke/moved	kg	3.8/4.3/1.0	7.7/6.7/1.9	22.6/15.2/4.7
Max. permissible drive torque < 1 m/s	Nm	31	71	174
at speed 1-3 m/s	Nm	25	60	148
at speed > 3 m/s	Nm	16	39	108
Linear route per motor revolution	mm	180	240	350
Max. rotary speed of the drive axle	min <sup>-1</sup>	3000	2500	1700
Repeat accuracy	mm/m	+/-0.05	+/-0.05	+/-0.05
Positioning accuracy*	mm/m	+/-0.15	+/-0.15	+/-0.15
Run accuracy	mm	+/-0.03/300	+/-0.03/300	+/-0.03/300

\*depends on various factors

# Linear Motor Modules

Type FTH



## FTH25A / FTH25B

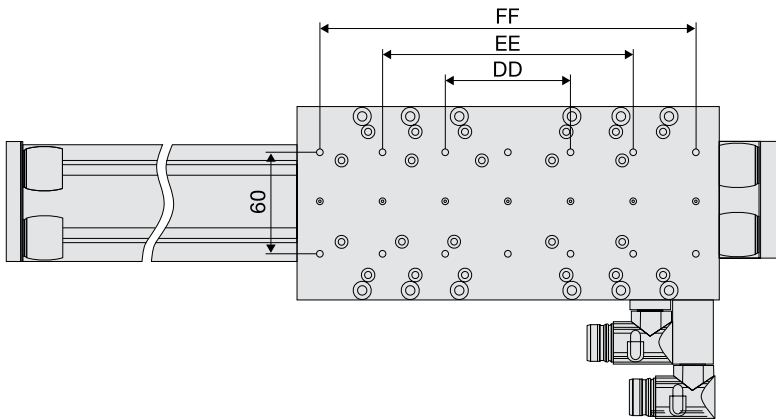
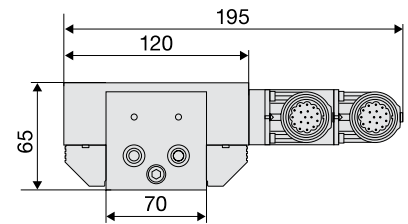
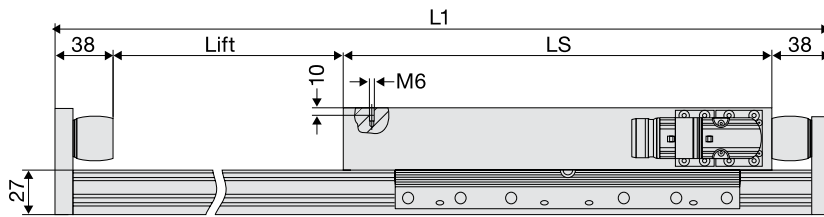

## Performance overview / designs

		FTH25A	FTH25B	Optional
Max. speed	m/s	9	4.5	
Max. acceleration	m/s <sup>2</sup>	100	100	
Max. traverse path	mm	3625	3530	longer traverse paths on request
Weight rail	kg/m	6	6	
Weight slide bed	kg	3	5	second slide bed
Power continuous	N	61	115	
Power peak	N	162	323	
Positioning accuracy*	mm/m	0.02	0.02	
Run accuracy	mm/m	0.04	0.04	
Repeat accuracy (resolution)	mm	0.02	0.02	
Input voltage U <sub>dc</sub>	V	310	310	
Continuous current I <sub>nc</sub>	A	2.1	2.1	
Peak current I <sub>peak</sub>	A	6	6	
Coil resistance R <sub>u-v</sub>		3.8	7.6	
Coil inductance L <sub>u-v</sub>	mH	20.4	40.7	
Width of pole pair	mm	24	24	
Temperature sensor	KTY81 (2000 Ohm/25 °C)			
Measuring system	1 Vpp (Auflösung 1 µm, Teilung 1 mm)			
End switch	-	2 end positions / 1 reference (PNP-Ö, PNP-S)		
Brakes	-	pneumatic		
Cover	-	bellows		
Cable drag chain	-	plastic / metal		

Special designs (e. g. water cooling, extended slide beds for greater loads, 2 slide beds etc.) on request.

## Materials

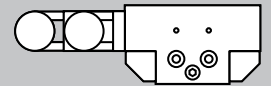

	Body material	Balls	Wipers	Cable
<b>Standard</b>	High-strength, anodized aluminium, steel raceways	Antifriction bearing steel 100Cr6	Plastic plate with felt wiper	
<b>Special</b>	Corrosion-resistant raceways	Corrosion-resistant rollers		Servoflex, drag chain-suitable up to 100 m/s <sup>2</sup> , highly flexible

## Dimensions

Stroke	Load ratings		Torque				Dimensions				Order no.	
	N		Nm		mm		mm					
	C	Co	Mcx	Mcy, Mcz	Mox	Moy, Moz	L1	LS	DD	EE	FF	
<b>FTH25A</b>												
265	7500	3700	293	165	145	82	506	165	75	150	-	<a href="#">93220A</a>
505	7500	3700	293	165	145	82	746	165	75	150	-	<a href="#">93221A</a>
745	7500	3700	293	165	145	82	986	165	75	150	-	<a href="#">93222A</a>
985	7500	3700	293	165	145	82	1226	165	75	150	-	<a href="#">93223A</a>
1225	7500	3700	293	165	145	82	1466	165	75	150	-	<a href="#">93224A</a>
1465	7500	3700	293	165	145	82	1706	165	75	150	-	<a href="#">93225A</a>
1705	7500	3700	293	165	145	82	1946	165	75	150	-	<a href="#">93226A</a>
1945	7500	3700	293	165	145	82	2186	165	75	150	-	<a href="#">93227A</a>
2185	7500	3700	293	165	145	82	2426	165	75	150	-	<a href="#">93228A</a>
2425	7500	3700	293	165	145	82	2666	165	75	150	-	<a href="#">93229A</a>
2665	7500	3700	293	165	145	82	2906	165	75	150	-	<a href="#">93230A</a>
2905	7500	3700	293	165	145	82	3146	165	75	150	-	<a href="#">93231A</a>
3145	7500	3700	293	165	145	82	3386	165	75	150	-	<a href="#">93232A</a>
3385	7500	3700	293	165	145	82	3626	165	75	150	-	<a href="#">93233A</a>
3625	7500	3700	293	165	145	82	3866	165	75	150	-	<a href="#">93234A</a>
<b>FTH25B</b>												
170	15000	7400	293	461	145	228	506	260	75	150	225	<a href="#">93235A</a>
410	15000	7400	293	461	145	228	746	260	75	150	225	<a href="#">93236A</a>
650	15000	7400	293	461	145	228	986	260	75	150	225	<a href="#">93237A</a>
890	15000	7400	293	461	145	228	1226	260	75	150	225	<a href="#">93238A</a>
1130	15000	7400	293	461	145	228	1466	260	75	150	225	<a href="#">93239A</a>
1370	15000	7400	293	461	145	228	1706	260	75	150	225	<a href="#">93240A</a>
1610	15000	7400	293	461	145	228	1946	260	75	150	225	<a href="#">93241A</a>
1850	15000	7400	293	461	145	228	2186	260	75	150	225	<a href="#">93242A</a>
2090	15000	7400	293	461	145	228	2426	260	75	150	225	<a href="#">93243A</a>
2330	15000	7400	293	461	145	228	2666	260	75	150	225	<a href="#">93244A</a>
2570	15000	7400	293	461	145	228	2906	260	75	150	225	<a href="#">93245A</a>
2810	15000	7400	293	461	145	228	3146	260	75	150	225	<a href="#">93246A</a>
3050	15000	7400	293	461	145	228	3386	260	75	150	225	<a href="#">93247A</a>
3290	15000	7400	293	461	145	228	3626	260	75	150	225	<a href="#">93248A</a>
3530	15000	7400	293	461	145	228	3866	260	75	150	225	<a href="#">93249A</a>

# Linear Motor Modules

Type FTH



## FTH35A / FTH35B

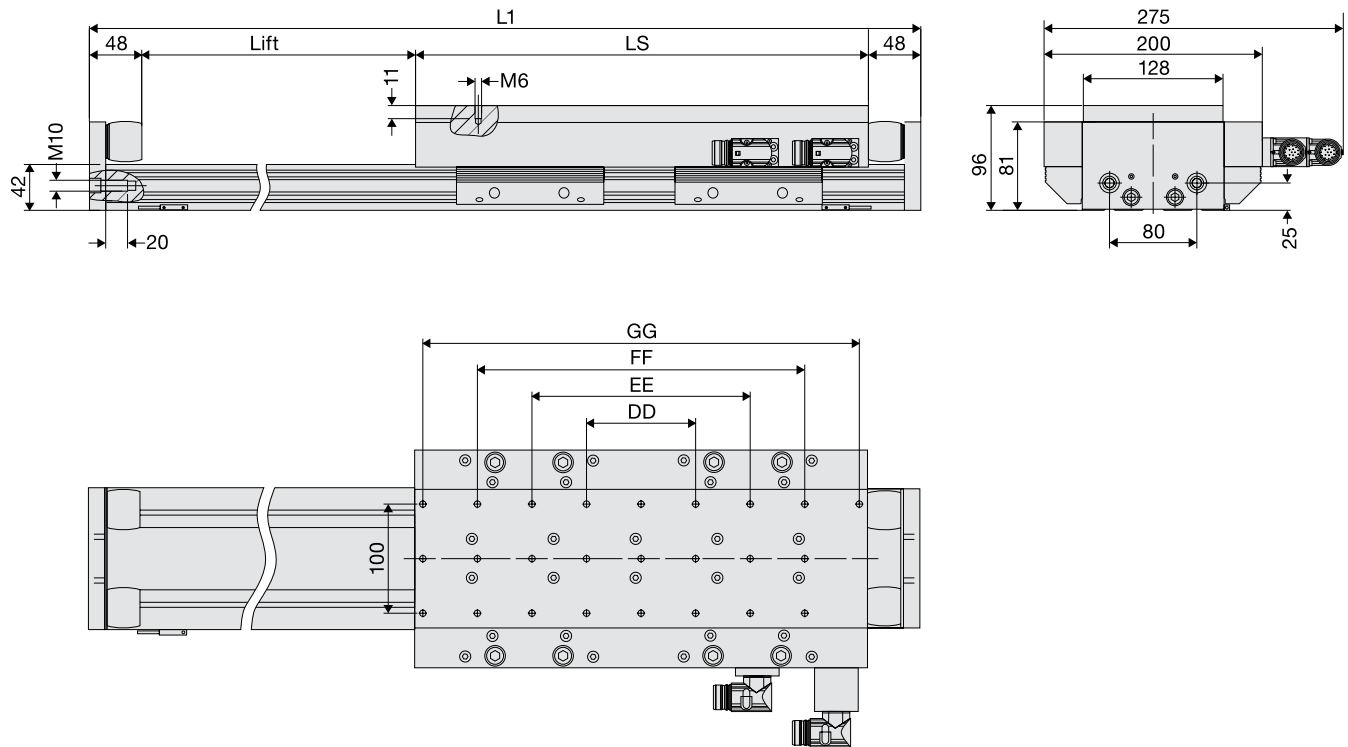

## Performance overview / designs

		FTH35A	FTH35B	Optional
Max. speed	m/s	6	6	
Max. acceleration	m/s <sup>2</sup>	100	100	
Max. traverse path	mm	3536	3361	longer traverse paths on request
Weight rail	kg/m	10	10	
Weight slide bed	kg	9	16	second slide bed
Power continuous	N	280	560	
Power peak	N	650	1300	
Positioning accuracy*	mm/m	0.02	0.02	
Run accuracy	mm/m	0.04	0.04	
Repeat accuracy (resolution)	mm	0.02	0.02	
Input voltage U <sub>dc</sub>	V	560	560	
Continuous current I <sub>nc</sub>	A	2.8	5.7	
Peak current I <sub>peak</sub>	A	8.0	16.0	
Coil resistance R <sub>u-v</sub>	Ω	7.4	3.7	
Coil inductance L <sub>u-v</sub>	mH	55	27	
Width of pole pair	mm	32	32	
Temperature sensor	KTY81 (2,000 Ohm/25 °C)			
Measuring system	1 Vpp (Resolution 1 μm, pitch 1 mm)		absolute measuring system	
End switch	-		2 end positions/1 reference (PNP-Ö, PNP-S)	
Brakes	-		pneumatic	
Cover	-		bellows	
Cable drag chain	-		plastic/metal	

Special designs (e. g. water cooling, extended slide beds for greater loads, 2 slide beds etc.) on request.



## Materials

	Body material	Balls	Wipers	Cable
<b>Standard</b>	High-strength, anodized aluminium, steel raceways	Antifriction bearing steel 100Cr6	Plastic plate with felt wiper	
<b>Special</b>	Corrosion-resistant raceways	Corrosion-resistant rollers		Servoflex, drag chain-suitable up to 100 m/s <sup>2</sup> , highly flexible

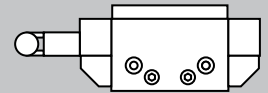

## Dimensions

Stroke	Load ratings		Torque				Dimensions						Order no.
	N		Nm				mm						
	C	Co	Mcx	Mcy, Mcz	Mox	Moy, Moz	L1	LS	DD	EE	FF	GG	
<b>FTH35A</b>													
208	29900	34500	1100	1000	1250	1150	544	240	100	200	-	-	92870A
464	29900	34500	1100	1000	1250	1150	800	240	100	200	-	-	92871A
720	29900	34500	1100	1000	1250	1150	1056	240	100	200	-	-	92872A
976	29900	34500	1100	1000	1250	1150	1312	240	100	200	-	-	92873A
1232	29900	34500	1100	1000	1250	1150	1568	240	100	200	-	-	92874A
1488	29900	34500	1100	1000	1250	1150	1824	240	100	200	-	-	92875A
1744	29900	34500	1100	1000	1250	1150	2080	240	100	200	-	-	92876A
2000	29900	34500	1100	1000	1250	1150	2336	240	100	200	-	-	92877A
2256	29900	34500	1100	1000	1250	1150	2592	240	100	200	-	-	92878A
2512	29900	34500	1100	1000	1250	1150	2848	240	100	200	-	-	92879A
2768	29900	34500	1100	1000	1250	1150	3104	240	100	200	-	-	92880A
3024	29900	34500	1100	1000	1250	1150	3360	240	100	200	-	-	92881A
3280	29900	34500	1100	1000	1250	1150	3616	240	100	200	-	-	92882A
3536	29900	34500	1100	1000	1250	1150	3872	240	100	200	-	-	92883A
<b>FTH35B</b>													
289	29900	34500	2150	3000	2500	3450	800	415	100	200	300	400	92884A
545	29900	34500	2150	3000	2500	3450	1056	415	100	200	300	400	92885A
801	29900	34500	2150	3000	2500	3450	1312	415	100	200	300	400	92886A
1057	29900	34500	2150	3000	2500	3450	1568	415	100	200	300	400	92887A
1313	29900	34500	2150	3000	2500	3450	1824	415	100	200	300	400	92888A
1569	29900	34500	2150	3000	2500	3450	2080	415	100	200	300	400	92889A
1825	29900	34500	2150	3000	2500	3450	2336	415	100	200	300	400	92890A
2081	29900	34500	2150	3000	2500	3450	2592	415	100	200	300	400	92891A
2337	29900	34500	2150	3000	2500	3450	2848	415	100	200	300	400	92892A
2593	29900	34500	2150	3000	2500	3450	3104	415	100	200	300	400	92893A
2849	29900	34500	2150	3000	2500	3450	3360	415	100	200	300	400	92894A
3105	29900	34500	2150	3000	2500	3450	3616	415	100	200	300	400	92895A
3361	29900	34500	2150	3000	2500	3450	3872	415	100	200	300	400	92896A

FTH35B is also available as a heavy duty version with double load rating.

## Clamping

Cassette with star grip or clamping lever for fixing to any position on the guide section. The clamping does not apply any force to the

guide system. It is used for manual devices, clamping and holding stops, instead of tools and machining parts. Let us advise you.

with star grip

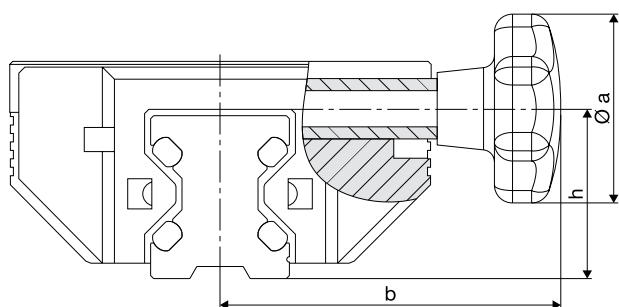

Size	Dimensions				Order no.	
	Ø a	b	h	N	Standard	Non-corrosive
15	25	41	19.0	200	<a href="#">84396AK</a>	<a href="#">84396NK</a>
20	25	49	23.0	250	<a href="#">84441AK</a>	<a href="#">84441NK</a>
25	32	56	28.0	250	<a href="#">84363AK</a>	<a href="#">84363NK</a>
35	50	83	38.5	350	<a href="#">84364AK</a>	<a href="#">84364NK</a>
45	63	101	48.0	750	<a href="#">84365AK</a>	<a href="#">84365NK</a>

with clamping lever

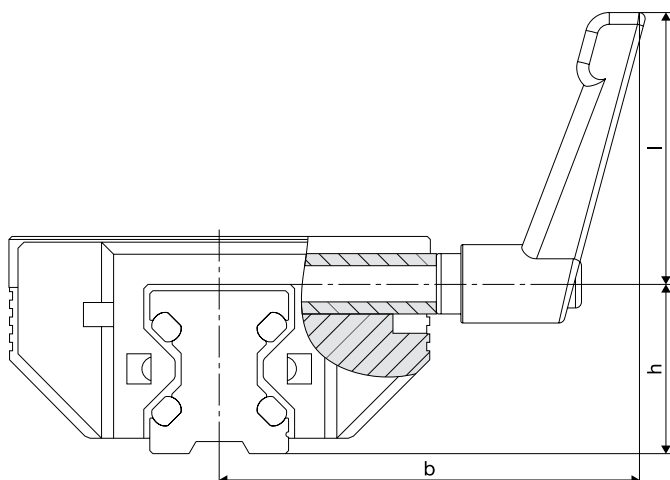

Size	Dimensions					Order no.	
	l	Wt.	b	h	N	Standard	Non-corrosive
15	45	M 5	59.5	64.0	200	<a href="#">84396AH</a>	<a href="#">84396NH</a>
20	45	M 5	67.5	68.0	250	<a href="#">84441AH</a>	<a href="#">84441NH</a>
25	45	M 6	71.0	73.0	250	<a href="#">84363AH</a>	<a href="#">84363NH</a>
35	63	M 8	96.0	101.5	350	<a href="#">84364AH</a>	<a href="#">84364NH</a>
45	78	M10	116.0	126.0	750	<a href="#">84365AH</a>	<a href="#">84365NH</a>

## Metal Wipers

The metal wipers are inserted in the wiper plate in addition to the felt wipers and clipped. They assist removal of coarse dirt, such as metal chips, welding chips or sawdust.

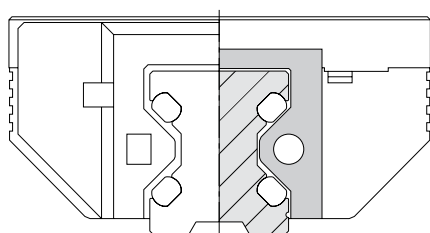

Size	Order no.
12	<a href="#">69126A</a>
15	<a href="#">69127A</a>
20	<a href="#">69128A</a>
25	<a href="#">69129A</a>
35	<a href="#">69130A</a>
45	<a href="#">69131A</a>

## Bellows

The bellows for Aluminium Roller Guides protect the guide system from coarse dirt. They are available in any length. Fixing to the cassette and end plate is effected using glued Velcro®. The

cassette wipers are not needed. Material: synthetic cloth with one-sided polyurethane coating, temperature: contact heat +80 °C, radiant heat +120 °C.

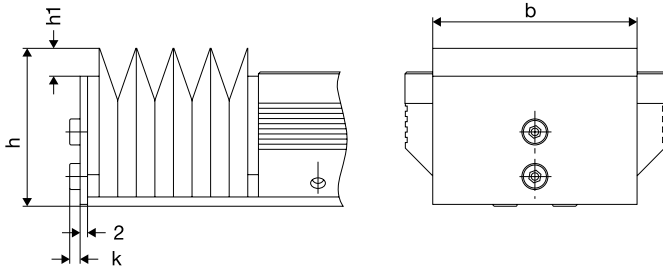

Size	Dimensions mm				Order no.
	b	h	h1	k	
15	42	31.0	7.0	2.8	on request
20	47	35.0	5.0	2.8	
25	55	42.5	6.5	2.8	
35	68	55.0	7.0	3.5	
45	87	67.0	7.0	3.5	

## Stop Screws

The stop screws are screwed to the guide rails in thread (option). A fitted rubber cap cushions impact. The bore shape is delivered

offset by a half bore jump for rail lengths with initial bore dimensions less than L11 min. Material: Chloroprene rubber (Cr), colour black.

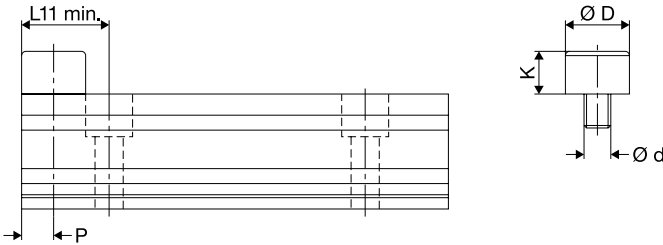

Size	Dimensions mm					Order no.
	d	D	K	L11 min.	P	
12	M 5	12	8	15.0	6.0	63504A
15	M 5	12	8	16.0	6.0	63504A
20	M 5	12	8	17.0	6.0	63504A
25	M 6	15	10	20.5	7.5	63505A
35	M 8	19	13	26.5	9.5	63506A
45	M10	24	16	33.0	12.0	63507A

## Caps

The borings of the guide rails should be closed with plastic caps for best function of the wipers. These caps are included in every

delivery. They can also be ordered separately as replacements. Material: POM wear-resistant plastic, oil and ageing-resistant.

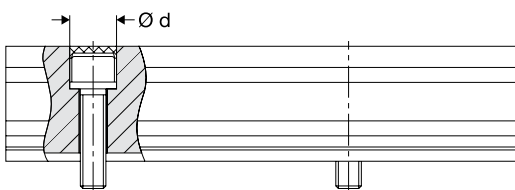

Size	Dimensions mm		Order no.
	Cylinder screw DIN912	D	
12	M 3	6	87752A
15	M 4	8	87753A
20	M 5	10	87754A
25	M 6	11	87755A
35	M 8	15	87756A
45	M10	18	87757A

## Linear Modules Type FTC/FTD

### Profile Fixings

#### MAE

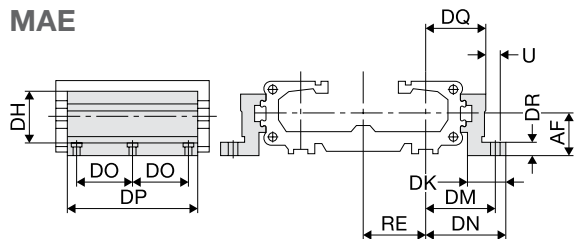

#### T-assembly rail

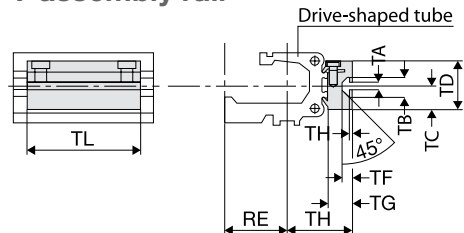

Size	Dimensions mm																		Order no.
MAE	R	U	AF	DF	DH	DK	DM	DN	DO	DP	DQ	DR	DT	EF	EM	EN	EQ	RE	
15	M5	5.5	22	27	38	26	40	47.5	40	92	34.5	8	10	41.5	28.5	49	36	26	92981A
20	M5	5.5	30	33	46	27	46	54.5	40	92	40.5	10	10	48.5	35.5	57	43	32	92982A
25/35	M6	7.0	48	40	71	34	59	67.0	45	112	52.0	10	11	64.0	45.0	72	57	44	92983A

Size	Dimensions mm										Order no.
T	RE	TA	TB	TC	TD	TE	TF	TG	TH	TL	
15	26	5.0	11.5	16	32	1.8	6.4	14.5	34.5	50	92835A
20	32	5.0	11.5	16	32	1.8	6.4	14.5	40.5	50	92836A
25/35	44	8.2	20.0	20	43	4.5	12.3	20.0	58.0	80	92837A

#### E1

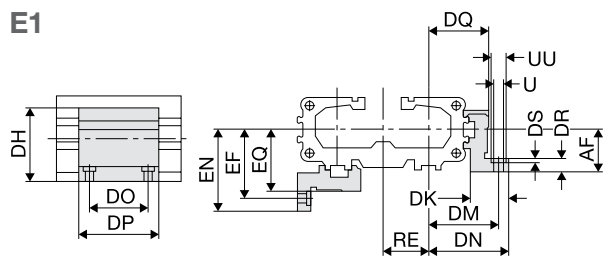

#### D1

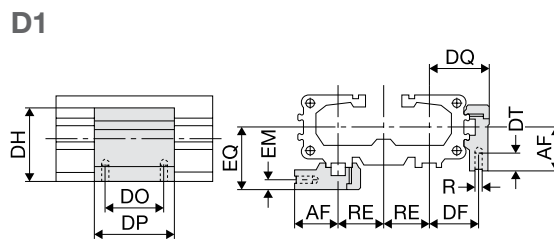

Size	Dimensions mm																			Order no.	
E1	R	U	UU	AF	DF	DH	DK	DM	DN	DO	DP	DQ	DR	DS	DT	EF	EM	EN	EQ	RE	
15	M5	5.5	10	22	27	38	26	40	47.5	36	50	34.5	8	5.7	10	41.5	28.5	49	36	26	92821A
20	M5	5.5	10	30	33	46	27	46	54.5	36	50	40.5	10	5.7	10	48.5	35.5	57	43	32	92826A
25/35	M6	7.0	-	48	40	71	34	59	67.0	45	60	52.0	10	-	11	64.0	45.0	72	57	44	92831A

Size	Dimensions mm																			Order no.	
D1	R	U	UU	AF	DF	DH	DK	DM	DN	DO	DP	DQ	DR	DS	DT	EF	EM	EN	EQ	RE	
15	M5	5.5	10	22	27	38	26	40	47.5	36	50	34.5	8	5.7	10	41.5	28.5	49	36	26	92820A
20	M5	5.5	10	30	33	46	27	46	54.5	36	50	40.5	10	5.7	10	48.5	35.5	57	43	32	92825A
25/35	M6	7.0	-	48	40	71	34	59	67.0	45	60	52.0	10	-	11	64.0	45.0	72	57	44	92830A

## Cover Fixings

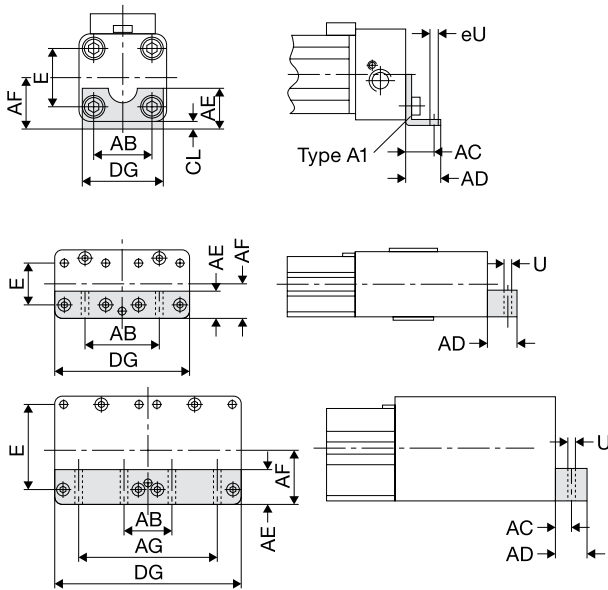

Size	Dimensions								Order no.
	mm								
A1	E	Ø U	AB	AC	AD	AE	AF	DG	
15	27	5.8	27	16	22	18	22	39	92810A
20	36	6.6	36	18	26	20	30	50	92813A

Size	Dimensions									Order no.
	mm									
C1	E	Ø U	AB	AC	AD	AE	AF	AG	DG	
15	27	6.6	52	16.0	25	25	22	-	91	92978A
20	36	9.0	64	18.0	25	25	30	-	114	92979A
25/35	70	9.0	48	12.5	30	30	48	128	174	92980A

## Intermediate Drive Shaft

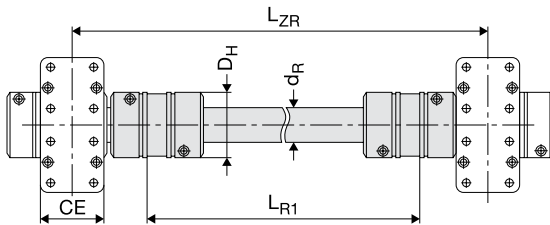

Size	Max. torque Nm	Dimensions						Order no.
		DH	Kb <sub>max</sub>	LD	mm		d <sub>R</sub>	
15	60	55	16 <sub>h7</sub>	5	<3000	L <sub>R1</sub> +112	30x4.0	92997A
20	60	55	22 <sub>h7</sub>	5	<3000	L <sub>R1</sub> +126	30x4.0	92998A
35	160	65	32 <sub>h7</sub>	5	<3000	L <sub>R1</sub> +167	35x4.0	92999A

## End Switch

RS	RS	ES	ES
Reed closer	Reed opener	PNP closer	NPN closer
Type:	Type:	Type:	Type:
RS-K	RS-K	ES-S	ES-S
92841A	92842A	92844A	92845A
RS-S	RS-S		
92847A	92843A		
Connection cable 5 m with coupling and open end			
Signal transmitter type ES-S/RS-S			
			92846A

## Type FD – Franke Dynamic

### 1 Designs and System Description

Aluminium Roller Guides from Franke are available as double rails with cassette or as a pair of single rails with a pair of roller shoes:

#### Double rail with cassette:

The double rail with cassette design is a Linear Guide ready-aligned as standard. Cassette and rail have standard connection borings.

#### Pair of single rails with pair of roller shoes (illustration 1):

Single rails with roller shoes are part of the construction with the advantage of a variable guide width. The mating plate is specified by the customer.



Illustration 1: Pair of Single Rails with Pair of Roller Shoes

The cassette or the pair of roller shoes of standard type FDA run on 4 crosswise needle bearing rollers on rails of tough spring steel. Other types are available for individual cases with special requirements, e.g. non-corrosive rails or also customer-specific special designs.

The Aluminium Roller Guides have lifetime lubrication. Traverse speeds of 10 m/s and accelerations of 40 m/s<sup>2</sup> can be realised. The operating temperature of the guides lies between -20 °C and +100 °C. Franke is happy to advise when solutions are requested that are suitable for temperatures outside of this range.

Cassettes mounted on rails are adjusted ex works free from clearance. It is possible to adjust the Aluminium Roller Guides to the individual load situation retrospectively using an integrated adjusting screw. The adjustment setting is best determined by measuring the slide resistance in the unloaded state (see illustration 2).



Illustration 2: Measuring Slide Resistance

The screwing of the cassette plate to the adjusting side is loosened slightly to adjust. Afterwards, the headless pin integrated in the cassette long side is readjusted. Turning the headless pin moves the roller shoe and, thus, increases or reduces the preload.

The adjustment values for the individual types are shown in table 3.6 Slide Resistances. Further details on fitting and adjusting the guide are given in the instruction manual for the Aluminium Roller Guides.

### 2 Dimensioning the Guides

The following parameters are needed for correct dimensioning of the guide:

- Selection of formation
- All invasive or emerging forces / torques (dynamic / static), (see illustration 3)
- Type of load (stationary, swelling, changing)
- Environmental influences (e.g. temperature, moisture) or special operation conditions (e.g. clean room, vacuum)
- Traverse speed and acceleration
- Stroke length
- Target lifetime in km

All forces and torques must be within the permissible limits. The relevant data are on the pages for the types.

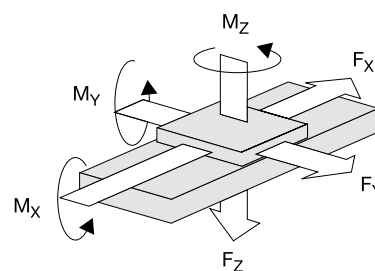

Illustration 3: Arrangement of forces and moments

Recommended safeties (for screw quality 8.8):

- Pressure load:  $s > 1.2$
- Tension load:  $s > 2.5$
- Moment load:  $s > 4.0$

### 3 Notes for Mating Structure

#### 3.1 Mating Plate for Type FD

A mating plate (bridging the roller shoes) must also be used when using single rails and roller shoes. The roller shoes and the mating plate together form the carriage.

Note on layout of the mating plate of the carriage: the roller shoes have centering grooves for better alignment during assembly. You apply a centering bar to the mating plate for this purpose (illustration 4). The dimensions for producing the centering bar are in table 1. All other dimensions, tolerances and accuracies for the guides are given on the relevant pages of the catalogue.

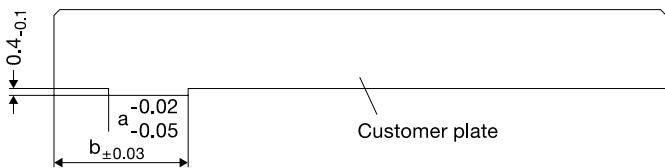

Illustration 4: Centering Shoulder

Size	a mm	b mm
12	4.5	9.6
15	5.0	12.6
20	7.5	16.1
25	10.5	17.6
35	12.5	26.1
45	15.5	31.1

Table 1: Dimensions Centering Bar

#### 3.2 Multi-Track Formations

It is recommended to define a fixed and movable bearing site on the carriage plate for multi-track formations. This is the best way to equalise tolerances between the rails.

For example, the movable bearing side can be designed with a carrier and a stroke safety. The fixed bearing side takes on the guide function, the movable bearing side equalises parallelism and height tolerances. It is recommended to locate the drive in direct proximity to the guide side, as the drive torque is taken from this.

#### 3.3 Mounting Surfaces

Contact and support surfaces essentially determine the function and precision of the guide. Inaccuracies can be added for running accuracy of the guide system. For example, double-track formations require precise parallelism and height alignment. The accuracies for the mounting and contact surfaces of the guides from table 2 must be maintained to guarantee running accuracy of the guide:

Size	12–20 mm	25–45 mm
Max. tolerance for parallelism	0.03	0.05
Max. evenness mounting surface	0.10	0.20

Table 2: Accuracies Contact and Support Surfaces

#### 3.4 Fixing the Rails

Depending on the type of load the guide rails should either:

1. be screwed
2. be screwed and dowelled
3. be laid against a contact shoulder and screwed (illustration 5).

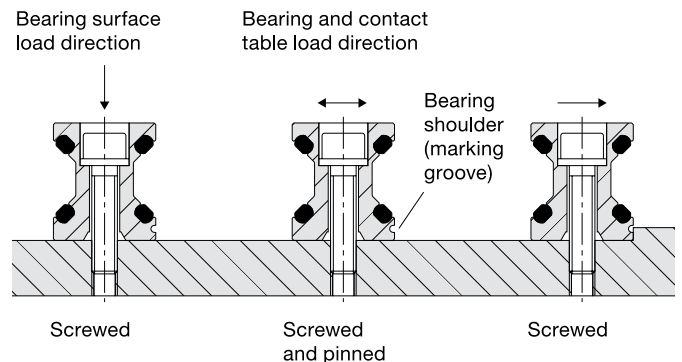

Illustration 5: Fixing Rails

The load capacity of the rails is influenced by the connections between the guide elements and the mating structure. Fixing to the mating structure is effected using screws of quality 8.8 with plain washers DIN 433.

#### 3.5 Fitting Instructions Coupled Rails

Rails over a length of 4000 mm are coupled according to Franke standards. Butt jointing according to Franke standards guarantees a universally even bore shape and optimum usage of the rail length. Divisions are also possible to customer specifications.

Coupled rails are specially aligned with one another. Therefore, the rails have sequential numbering for the right fitting (e.g. A/1-1/1-2/2-2/E).



Illustration 6: Coupled Rails / Auxiliary Cylinders

The rails are also marked with a groove on the rail underside, which must always be on the same side. The rails must be arranged free of play. The corresponding auxiliary cylinders (illustration 6) are used for this. The dimensions for the design of the auxiliary cylinders are in table 3. The cylinders are inserted at the joints of the rails in the raceway and preloaded using a device.

Size	Auxiliary Cylinder mm
12	11
15	11
20	14
25	16
35	27
45	35

Table 3: Dimensions Auxiliary Cylinder

The relevant tightening torques for the individual screws are given in table 4.

Screws	Tightening Torque
M 3	1.1
M 4	2.5
M 5	5.0
M 6	8.5
M 8	21.0
M10	41.0
M12	71.0

Table 4: Tightening Torques Screws

### 3.6 Slide Resistances

Size	Slide Resistance N							
	FDA	FDB	FDC	FDD	FDE	FDG	FDH	
12	Min.	0.2	0.2	0.5	-	0.5	0.6	-
	Max.	0.4	0.4	1.0	-	3.0	0.9	-
15	Min.	0.5	0.5	0.5	-	1.0	0.5	-
	Max.	2.0	1.0	2.0	-	3.0	1.5	-
20	Min.	1.0	0.5	1.0	-	1.0	1.0	-
	Max.	2.5	1.5	2.5	-	3.0	3.0	-
25	Min.	1.5	0.5	1.5	1.5	1.5	0.5	2.5
	Max.	3.0	2.0	3.0	3.0	3.0	2.0	5.0
35	Min.	2.0	1.0	2.0	-	2.0	1.0	4.0
	Max.	4.0	2.5	4.0	-	4.0	2.5	7.0
45	Min.	2.5	2.0	2.5	-	2.5	2.0	5.0
	Max.	5.0	4.0	5.0	-	5.0	4.0	8.0

### 3.7 Running Accuracy and Stiffness

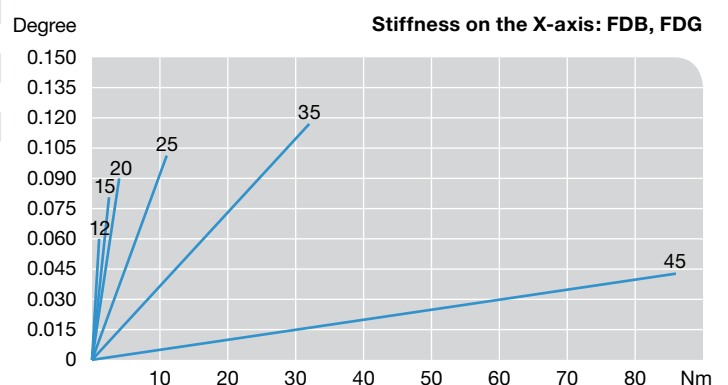
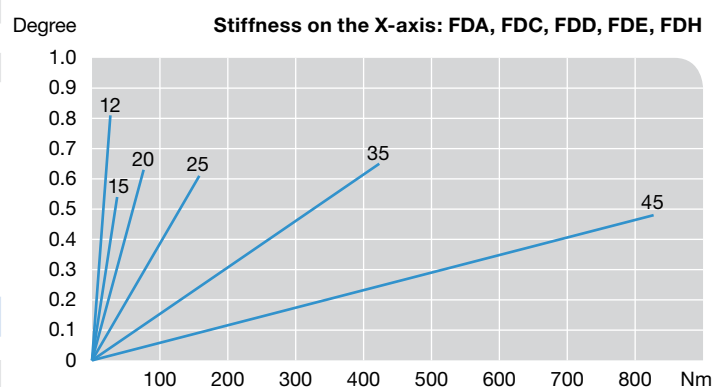
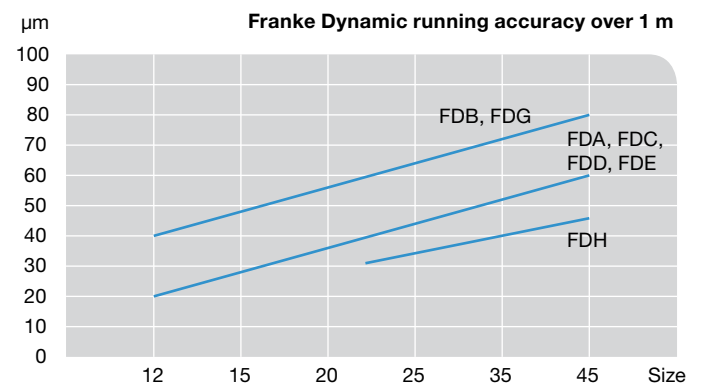



## Type FP – Franke Power

### 1 Designs and System Description

Franke Linear Guides of the type FPA comprise double rails with cassette. The cassette has integrated recirculating rollers for high load ratings and stiffness. The rails of the type FPA are interchangeable with the rails of the Franke Aluminium Roller Guide.

Franke Recirculating Roller Guides are available in one preload class. Traverse speeds of 3 m/s and accelerations of 30 m/s<sup>2</sup> are possible. The operating temperature of the guides lies between -20 °C and +80 °C.

### 2 Dimensioning the Guides

The following parameters are needed for correct dimensioning of the guide:

- Selection of formation
- All invasive or emerging forces / torques (dynamic / static), (see illustration 1)
- Type of load (stationary, swelling, changing)
- Environmental influences (e.g. temperature, moisture) or special operating conditions (e.g. clean room, vacuum)
- Traverse speed and acceleration
- Stroke length
- Target lifetime in km

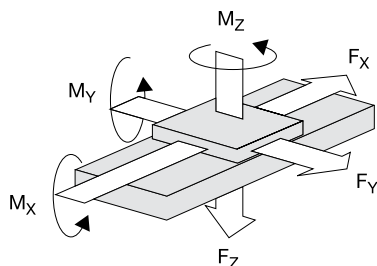

Illustration 1: Arrangement of forces and moments

All forces and torques must be within the permissible limits. The relevant data are on the pages for the individual types.

Recommended safeties (for screw quality 8.8):

- Pressure load:  $s > 1.2$
- Tension load:  $s > 2.5$
- Moment load:  $s > 4.0$

Calculations can be performed by Franke.

### 3 Notes for Mating Structure

#### 3.1 Multi-Track Formations

It is recommended to define a fixed and movable bearing site on the carriage plate for multi-track formations. This is the best way to equalise tolerances between the rails.

For example, the movable bearing side can be designed with a carrier and a stroke safety. The fixed bearing side takes on the guide function, the movable bearing side equalises parallelism and height tolerances. It is recommended to locate the drive in direct proximity to the guide side, as the drive torque is taken from this.

#### 3.2 Mounting Surfaces

Contact and support surfaces essentially determine the function and precision of the guide. Inaccuracies can be added for running accuracy of the guide system. For example, double-track formations require precise parallelism and height alignment. The accuracies for the mounting and contact surfaces of the guides from table 1 must be maintained to guarantee running accuracy of the guide:

Size	25 mm
Max. tolerance for parallelism	0.05
Max. evenness mounting surface	0.20

Table 1: Accuracies Bearing and Contact Surfaces

All other dimensions, tolerances and accuracies for the guides are given on the relevant pages of the catalogue.

#### 3.3 Fixing the Rails

Depending on the type of load the guide rails should either:

1. be screwed
2. be screwed and dowelled
3. be laid against a contact shoulder and screwed (illustration 2).

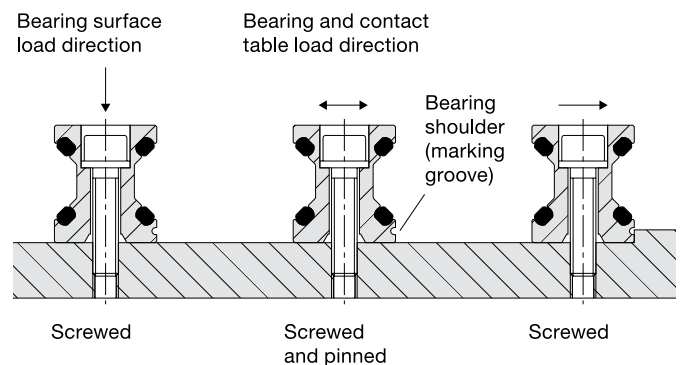

Illustration 2: Fixing Rails

The load capacity of the rails is influenced by the connections between the guide elements and the mating structure. Fixing to the mating structure is effected using screws of quality 8.8 with plain washers DIN 433.

### 3.4 Fitting Instructions Coupled Rails

Rails over a length of 4000 mm are coupled according to Franke standards. Butt jointing according to Franke standards guarantees a universally even bore shape and optimum usage of the rail length. Divisions are also possible to customer specifications.

Coupled rails are specially aligned with one another. Therefore, the rails have sequential production numbering for the right fitting (e.g. A/1-1/1-2/2-2/E).

The rails are also marked with a groove on the rail underside, which must always be on the same side. The rails must be arranged free of play. The corresponding auxiliary cylinders (illustration 3) are used for this. The dimensions for the design of the auxiliary cylinders are in table 2. The cylinders are inserted at the joints of the rails in the raceway and preloaded using a device.



Illustration 3: Coupled Rails/Auxiliary Cylinders

Size	Auxiliary Cylinder mm
25	16

Table 2: Dimensions Auxiliary Cylinder

The relevant tightening torques for the individual screws are given in table 3.

Screws	Tightening Torque
M6	8.5
M8	21.0

Table 3: Tightening Torques Screws

### 4 Lubrication

The Recirculating Roller Guides are initially lubricated ex works. After approx. 2000 km of running performance, the guides must be relubricated with 1 to 2 grams of lubricant.

### 5 Slide Resistances

Size	Slide resistance N	
		FP
25	Min.	17.5
	Max.	30.0

### 6 Running Accuracy and Stiffness

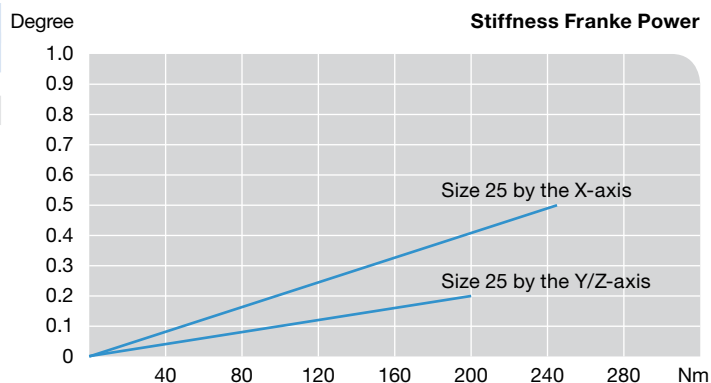
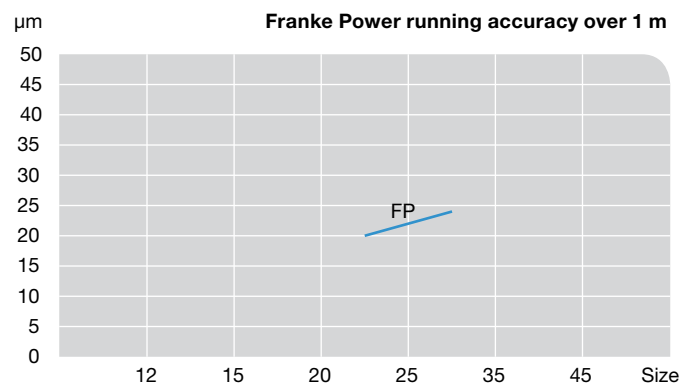

## Type FR – Franke Robust

### 1 Designs and System Description

Aluminium Recirculating Ball Guides of type FRA comprise two individual rails and recirculating elements. The recirculating elements are mounted on the mating plate and together form the carriage. The construction of the mating plate is specified by the customer.

Guides of the type FRA are particularly robust and have high load capacity. The max. traverse speed is 3 m/s, the max. acceleration is 30 m/s<sup>2</sup>. Use is possible in a temperature range of -10 °C to +80 °C.

The slide resistance can be adjusted for Linear Guides of the type FRA. The fixing screws on the slider plate on the adjustment side must be loosened. Using an optional tool the recirculating element can be moved towards the carriage plate and the adjustment is altered. The adjustment setting is best determined by measuring the slide resistance in the unloaded state.

The adjustment values are shown in table 5 Slide Resistances. Further details on fitting and adjusting the guide are given in the instruction manual for the Aluminium Recirculating Ball Guides.

### 2 Dimensioning the Guides

The following parameters are needed for correct dimensioning of the guide:

- Selection of formation
- All invasive or emerging forces / torques (dynamic / static), (see illustration 1)
- Type of load (stationary, swelling, changing)
- Environmental influences (e.g. temperature, moisture) or special operating conditions (e.g. clean room, vacuum)
- Traverse speed and acceleration
- Stroke length
- Target lifetime in km

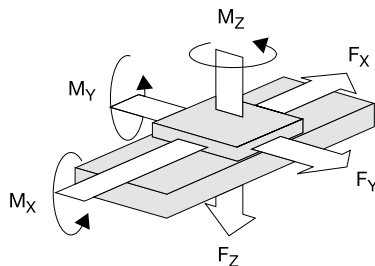

Illustration 1: Arrangement of forces and moments

All forces and torques must be within the permissible limits. The relevant data are on the pages for the individual types.

Recommended safeties (for screw quality 8.8):

- Pressure load:  $s > 1.2$
- Tension load:  $s > 2.5$
- Moment load:  $s > 4.0$

Calculations can be performed by Franke.

### 3 Notes for Mating Structure

#### 3.1 Mounting Surfaces

Contact and support surfaces essentially determine the function and precision of the guide. Inaccuracies can be added for running accuracy of the guide system. Therefore, the linearity and parallelism of the mating structure must be considered. The maximum permissible deviation across the whole stroke is 0.04 mm.

#### 3.2 Fixing the Rails

The rails are fixed against a bearing shoulder and screwed (see illustration 2). The two guide rails must be fitted parallel to one another. This is how you control the linearity and parallelism of the rails. The maximum total error must be less than 0.06 mm.

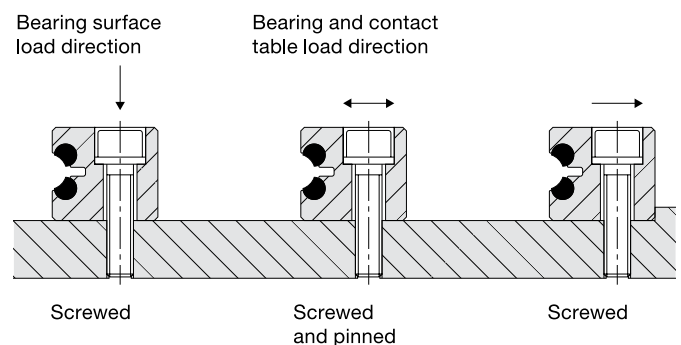

Illustration 2: Fixing Rails

The load capacity of the rails is influenced by the connections between the guide elements and the mating structure. Fixing to the mating structure is effected using screws of quality 8.8 with plain washers DIN 433.

Note: the raceways of the type FRA 08-13 can be exchanged in the event of wear. A rail's raceways must always be completely exchanged. The new raceways are ordered according to the original order or the item number of the rail.

### 3.3 Fitting Instructions Coupled Rails

Rails over a length of 4000 mm are coupled according to Franke standards. Butt jointing according to Franke standards guarantees a universally even bore shape and optimum usage of the rail length. Divisions are also possible to customer specifications.

Coupled rails are specially aligned with one another. Therefore, the rails have sequential production numbering for the right fitting (e.g. A/1-1/1-2/2-2/E). The top side of the rails is consistently marked with a bevel.

The rails must be evenly aligned during fitting. There must be a fitting gap between the rails. The rails should be fitted at a temperature of approx. 20 °C. The screw tightening torques from table 1 apply in this instance:

Screw	Tightening Torque
M 5	6.0
M 6	10.0
M 8	25.0
M 10	49.0

Table 1: Tightening Torques Screws FRA

There are more detailed instructions on fitting the rails in the instruction manual for Franke Linear Guides with Recirculating Balls.

### 4 Lubrication

The Aluminium Recirculating Ball Guides must always be coated with a film of lubricant. The system needs to be lubricated every 500 to 700 operating hours or 1 to 2 times a year.

Recirculating elements are connected to central lubrication as standard. This provides relubrication via the boring on the mounting surface.

### 5 Slide Resistances

Size	Slide Resistance per Pair of Recirculating Elements	
	N	FR
6	35–	45
8	60–	80
10	90–	120
13	150–	200

### 6 Running Accuracy

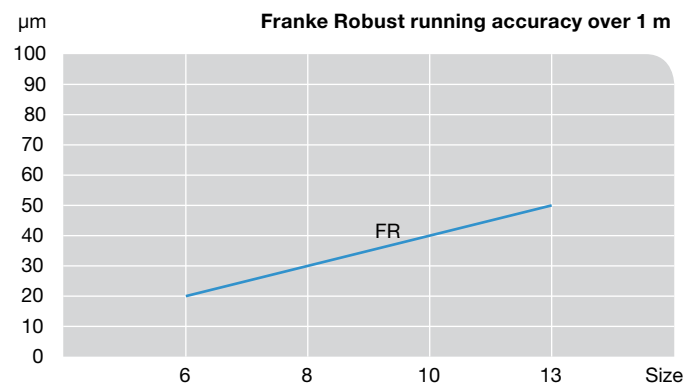

## Linear Tables/Modules

### 1 Design

Franke Linear Systems are suitable for example for automation tasks in measuring and testing processes or for rationalisation in the handling and fitting sector. The selection ranges from strokes from 100 mm to 7000 mm, drive is effected via a spindle or belt drive. The light aluminium construction combined with the integrated Franke guide system allows high load ratings and torque loads. Precise technical details are on the relevant pages in the catalogue.

### 2 Area of Use

We recommend use of Franke Linear Systems with safety  $s \geq 3$  for simple loads or acceleration and moment loads. A safety of  $s \geq 6$  should be used for dynamic torques. You can choose any installation position. We recommend a bedstop or a brake for vertical operation.

The position accuracy of the type FTB Linear Systems is  $\pm 0.025/300\text{mm}$  (IT7) in accordance with the spindle stiffness accuracy. Other accuracies are possible on request. The repeat accuracy is  $\leq 0.01\text{mm}$ . The run accuracy of the FTB Linear Tables is  $0.02/300\text{ mm}$ . Franke Linear Tables can be used in a temperature range of  $-20\text{ }^\circ\text{C}$  to  $+80\text{ }^\circ\text{C}$ . The FTD 15 – 35 Linear Systems are suitable for permanent operation at temperatures of  $-30\text{ }^\circ\text{C}$  to  $+80\text{ }^\circ\text{C}$ . Please contact us concerning use in other temperature ranges.

### 3 End Switches and Reference Switches

- Reference switches: Franke Linear Systems of type FTB have inductive proximity switches, which are set to the final stroke position. A further proximity switch can be provided as a reference switch if desired. With the type FTC and FTD Linear Modules there is the possibility of attaching a freely adjustable end switch to the outside. Franke Linear Systems are equipped with inductive end and reference switches PNP-nc 10-30VDC as standard. PNP-no, NPN-no and NPN-nc switches are available on request. The addition or integration of a length measuring system with sinus or square wave signal is possible on request. Shaft encoders can be mounted on the motor.
- Multi axis units: Franke Linear Systems can be combined to form multi-axle units. The necessary angles and adaptor plates are selected according to your needs. We supply completely fitted units, ready cabled and aligned, with other accessories on request.
- Motorisation: An array of step or servo motors can be connected to the Linear Systems. Connection flanges and couplings are modified accordingly. The customer's own motors can also be considered.

- Motor Redirection, Gears: the motor is mounted in the extension of the stroke axle as standard. For special applications, e.g. in limited space, a motor redirection can be integrated on request using a toothed belt or reversing gears.

Please call us.

### 4 Maintenance and Lubrication

Franke Linear Systems are low-maintenance and have lifetime lubrication ex works. No relubrication is required up to the ball screw. In the event of grease escaping through the spindle, relubrication – depending on the individual case – is required. We recommend relubrication at intervals of approx. 700 working hours with approx. 1–2 g grease. If necessary clean the inner areas and the guide tracks and coat these with grease.

Fully synthetic lubricants are preferred for long-term lubrication. Franke uses the fully synthetic special lubricant ISOFLEX TOPAS NCA52 at the factory (manuf. Klüber). We recommend high-quality lithium-saponificate grease based on mineral oil. When mixing lubricants, the compatibility of the variants must be considered with regard to type of base oil, thickening agent, base oil viscosity and NLGI class. For extreme conditions or extraordinary operating conditions (vacuum, radiation, high temperature), you should speak to us or the lubricant manufacturer.

### 5 Definitions

- The running accuracy is the greatest possible deviation of any one place on the moved table surface from the ideal straight lines when the entire stroke track passes (subject to the unevenness of the subconstruction).
- The position accuracy is the greatest possible deviation from the achievement of a preselected point, which is passed from a predefined point of origin.
- The repeat accuracy is the greatest possible deviation from the multiple achievement of a preselected point. The measuring system used is crucial for the level of accuracy.
- The resolution is the smallest possible traverse path. It depends on the spindle pitch, the ratio, the step angle and the classification of the measuring system. Errors in the positioning or repeat can be neutralised using the resolution. Therefore, it should always be greater than the deviation from the permissible position accuracy.

**Please follow assembly and maintenance instructions. They are included with every delivery.**

## Type FTH

### 1 Design

Franke Linear Motor Modules FTH Drive are suitable for example for tasks in measuring and testing processes as well as in the handling and fitting sector. Strokes from 200 mm to 5,300 mm are available. Drive is effected via an integrated linear motor. The light aluminum construction of the integrated Franke guide system allows high load ratings and torque loads.

### 2 Area of Use

We recommend use with safety  $S \geq 3$  for simple loads or acceleration and moment loads. A safety of  $S \geq 6$  should be used for dynamic torques. You can choose any installation position. We recommend a bedstop or a brake for vertical operation.

Franke Linear Motor Modules FTH Drive can be used in a temperature range of  $-20\text{ °C}$  to  $+80\text{ °C}$ . Please speak to us about use in other temperature ranges.

### 3 Accuracy

The positioning accuracy is  $\pm 0.01\text{ mm/m}$  and depends on the measuring system used. Other accuracies and measuring systems are possible. The repeat accuracy is  $\leq 0.02\text{ mm}$ . The running accuracy is  $0.04\text{ mm/m}$ .

### 4 Dynamic

The performance given in the diagrams (page 119) can be realized with Franke Linear Motor Modules FTH Drive. These are guide values that relate to the horizontal feed motion in the trapeze and triangle positioning. We are happy to design the perfect linear motor for your application.

### 5 Motorization

The Linear Motor Modules FTH Drive are powered by linear servomotors without mechanical drive components. The linear motor consists of a slide element and guide element. The slide element houses the coils, the position acquisition and temperature monitoring. The drive magnets are located in the guide element.

The linear motors used are characterized by extremely high power density (highest dynamic with smallest size), thus, facilitating acceleration up to  $100\text{ m/s}^2$  and movement speeds up to  $9\text{ m/s}$ .

### 6 Control



Dimensions		
mm		
h (incl. ventilator)	w	d (incl. connector)
345	70	243

We recommend the S700 amplifier from Kollmorgen to power the Linear Motor Modules FTH Drive. The S700 offers many special features, e. g. the free graphic Windows® software to operate the amplifier. The Auto-Tuning function also simplifies operation. A Safe Torque Off is included as standard. The S700 can memorize many different return systems and can evaluate up to three lots of position information in parallel.

You can get more information from our service team or in the internet at [www.kollmorgen.com](http://www.kollmorgen.com).

### 7 Measuring System and End and Reference Switches

Franke Linear Motor Modules are equipped with an integrated, magnetic length measuring system as standard. The positioning accuracy is  $\pm 10\text{ }\mu\text{m}$  with a resolution of  $\pm 1\text{ }\mu\text{m}$ . Absolute measuring systems can also be fitted.

Inductive proximity switches are available to record end or reference positions, which can be freely positioned in the guide profile.

### 8 Multi-Module Units

Linear Motor Modules of type FTH Drive can be combined into multi-module units. The necessary angles and adaptor plates are selected according to your needs. We supply completely fitted units, ready cabled and aligned, with other accessories on request.

**Please follow assembly and maintenance instructions. They are included with every delivery.**

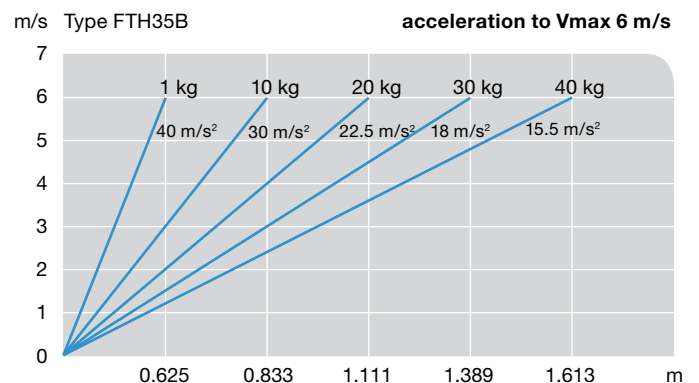
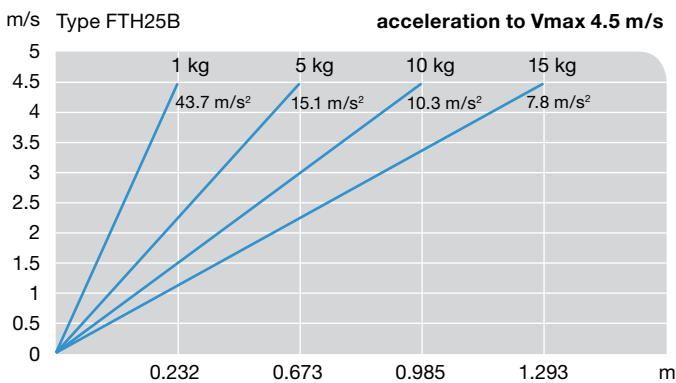
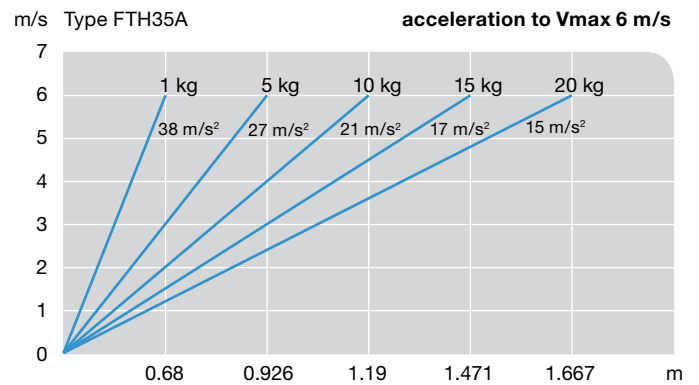
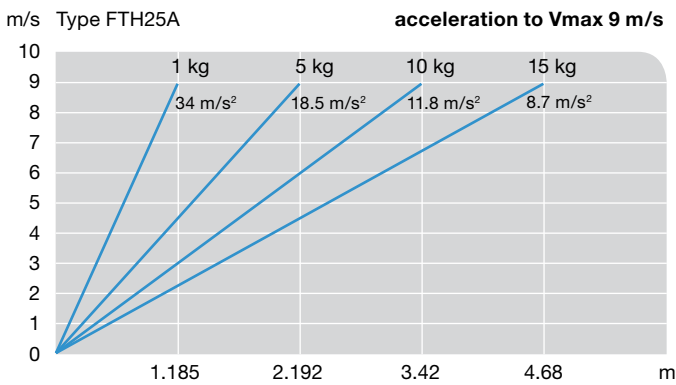
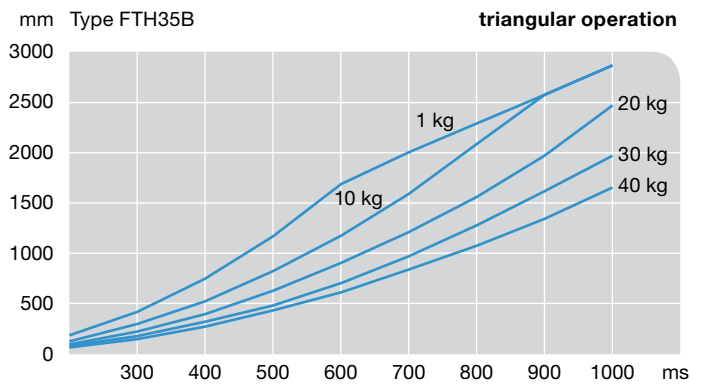
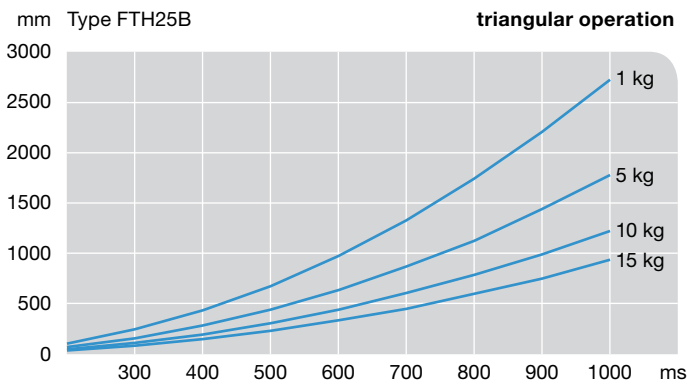
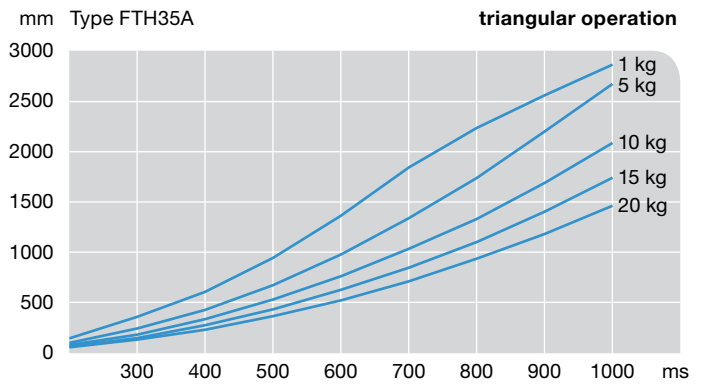
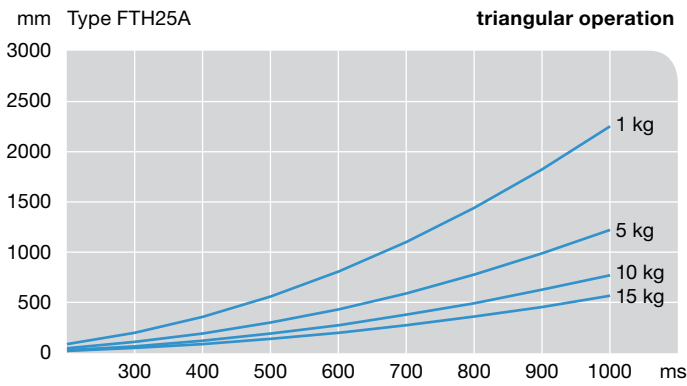

## Your Partners. Presenting the Franke Team.

Taking care of customers from A to Z competently and reliably – that is the declared Franke target. Whether further information on the products, specific offers, technical sales on site, training or support on maintenance – our staff are gladly there for you for all queries concerning Antifriction Bearings and Linear Systems.



## Management

(from the left)

<b>Daniel Groz</b>	Managing Director
<b>Sascha Eberhard</b>	Managing Director
<b>Jörg Egelhaaf</b>	Technical Manager
<b>Harald Müller</b>	Production Manager
<b>Günter Fischer</b>	Sales Manager
<b>Oliver Schröder</b>	Purchasing Manager



## Reception



**Manuela Neher**  
Tel. +49 7361 920-0  
info@franke-gmbh.de



**Brigitte Wild**  
Tel. +49 7361 920-0  
info@franke-gmbh.de

## Technical Advice



**Stephan Kuhn**  
Tel. +49 7361 920-180  
s.kuhn@franke-gmbh.de



**Thilo Deutsch**  
Tel. +49 7361 920-113  
t.deutsch@franke-gmbh.de



**Christian Burghard**  
Tel. +49 7361 920-124  
c.burghard@franke-gmbh.de



**Arne Jankowski**  
Tel. +49 7361 920-185  
a.jankowski@franke-gmbh.de

## Sales Advice



**Alexandra Stoll**  
Tel. +49 7361 920-112  
a.stoll@franke-gmbh.de



**Heike Faustmann**  
Tel. +49 7361 920-122  
h.faustmann@franke-gmbh.de



**Marlen Maier**  
Tel. +49 7361 920-123  
m.maier@franke-gmbh.de



**Petra Abele**  
Tel. +49 7361 920-121  
p.abele@franke-gmbh.de

## Germany

**Technisches Büro Tober**  
Langenberger Straße 21 H  
09337 Callenberg  
Tel. +49 3723 6686-87  
Fax +49 3723 6686-89  
Mobile +49 172 7326532  
franke@tober-gmbh.de

**Ing. Michael Topf**  
Rheinstraße 7  
15732 Eichwalde  
Tel. +49 30 67539783  
Fax +49 30 67539784  
Mobile +49 172 3064469  
michael.topf@t-online.de

**an-tec**  
**Mechanische Antriebstechnik**  
**Kristian Pölk**  
Willi-Eichler-Straße 11  
37079 Göttingen  
Tel. +49 551 48967-35  
Fax +49 551 48967-34  
Mobile +49 163 7976355  
k.poelk@an-tec.de

**Andreas Böttcher**  
Unterer Eickeshagen 52  
42555 Velbert  
Tel. +49 2052 925730  
Fax +49 2052 925731  
a.boettcher@franke-gmbh.de

**Ingenieurbüro Lothar Meyer**  
Pfalzstraße 5  
65329 Hohenstein  
Tel. +49 6128 450080  
Fax +49 6128 450079  
Mobile +49 172 8284128  
lotharmeyer@web.de

**Janotec Handelsvertretung**  
**Joachim Janot**  
Gutenbergstraße 13  
73430 Aalen  
Tel. +49 7361 680660  
Fax +49 7361 680662  
Mobile +49 172 7396071  
janot@janotec.de



**Christian Burghard**  
Obere Bahnstraße 64  
73431 Aalen  
Tel. +49 7361 920-124  
Fax +49 7361 920-120  
Mobile +49 173 3234833  
c.burghard@franke-gmbh.de

**Volker Schmerreim GmbH**  
Dorfweg 12  
83093 Bad Endorf  
Tel. +49 8053 9058  
Fax +49 8053 3593  
Mobile +49 170 8317522  
info@schmerreim.de

## Europe

**Austria**  
**Bell Maschinenelemente**  
(ZIP 3, 4, 5)  
Billrothstraße 32  
4050 Traun  
Tel. +43 6644 227912  
Fax +43 7229 75546  
office@bell.co.at

**Czech Republic**  
**Betz S.R.O.**  
Třída Vítězství 68/4  
35301 Mariánské Lázně  
Tel. +420 354 620095  
Fax +420 354 627307  
betz@betz.cz

**France**  
**Agora Technique**  
8 Bis Rue Volta, Parc Volta  
94140 Alfortville  
Tel. +33 1 45184370  
Fax +33 1 45184371  
benitah.agora@wanadoo.fr

**Great Britain**  
Antifriction Bearings  
**Franke Bearings Ltd.**  
Unit 5/90, Berry Lane  
Longridge, PR3 3WH  
Tel. +44 1772 780200  
Fax +44 1772 780909  
sales@linearmotionssystem.co.uk

Linear Systems  
**LMS Linear Motion Systems Ltd.**  
Unit 5/90, Berry Lane  
Longridge, PR3 3WH  
Tel. +44 1772 780200  
Fax +44 1772 780909  
sales@linearmotionssystem.co.uk

**Hungary**  
**Franke Csapágy Hungary Kft.**  
Bécsi út 117.  
2510 Dorog  
Tel. +36 70 7732 464  
Fax +36 33 4439 43  
info@franke-csapagy.hu

## Italy

### HTC Srl

Via XXIV Maggio 40  
10082 Cuornè TO  
Tel. +39 0124 651916  
Fax +39 0124 690205  
info@htcfranke.it

## Netherlands/Belgium

### Gileon Technical Components

Eindsestraat 129A  
5105 NA Dongen (Netherlands)  
Tel. +31 85 2017 814  
Fax +31 84 8399 240  
Mobile +31 627 046413  
info@gileon.nl

## Poland

### JORDAN matcon Sp. z o.o.

Kijewo 50  
63-000 Sroda Wielkopolska  
Tel. +48 61 286 07 00  
Fax +48 61 286 07 10  
info@jordan-matcon.pl

## Portugal

### Iberacero S.L.

Rua Outeiro, Lote 45, Gemunde  
4475-150 Maia  
Tel. +351 229 479 020  
Fax +351 229 479 029  
geral@iberacero.pt

## Spain

### Vorkauf Sociedad Anonima

Avda. Comandante Franco, 3  
28016 Madrid  
Tel. +34 91 3591712  
Fax +34 91 3500431  
vorkauf@vorkauf.es

### ASP Automatic System Partners

Pol. Ind. El Nogal  
C/ El Nogal 8  
28110 Algete, Madrid  
Tel. +34 916 290 900  
Fax +34 916 282 554  
info@asp-es.com

## Sweden/Denmark

### Bengtssons Maskin AB

Företagsvägen 14  
23237 Arlöv (Sweden)  
Tel. +46 40 6807300  
Fax +46 40 430271  
info@bengtssons-maskin.se

## Switzerland

### Emil Vögelin AG

Rindustrasse 476  
4303 Kaiseraugst  
Tel. +41 61 8169016  
Fax +41 61 8169000  
info@voegelinag.ch

## Turkey

### HPA Teknoloji Gelistirme Ltd. Sti.

1201 / 1 sokak no: 4/A  
Temsil Plaza P:21, Yenişehir  
35110 Izmir  
Tel. +90 232 469 7961  
Fax +90 232 433 9625  
info@hpa.com.tr

## North America

### Canada

#### Franke North American Head Quarters

Toronto Airport Business Center  
2425 Matheson Blvd. E, 8th Floor  
Toronto, ON, L4W 5K4  
Tel. +1 905 361 2855  
Fax +1 866 748 4067  
info@frankebearings.com

### USA

Antifriction Bearings

#### Rotek Inc.

1400 South Chillicothe Rd.  
P.O. Box 312  
Aurora, Ohio 44202  
Tel. +1 330 562 4000  
Fax +1 330 562 7394  
sales@rotek-inc.com

Linear Systems

#### Parker Hannifin Pneumatic Division

8676 East M89  
Richland MI 49083  
Tel. +1 330 335 2153  
Fax +1 330 335 0924  
dbugajski@parker.com

## Middle East

### Israel

#### American Aviation Ltd.

17 Hatidhar st.  
Ind. Zone Raanana 43000  
Tel. +972 9 7487826  
Fax +972 9 7487830  
yoav@amav.co.il

## Asia

### China

#### Sinotech Asia Ltd.

Unit 1503, Tower 5,  
China Hong Kong City,  
33 Canton Road, Kowloon  
Hong Kong  
Tel. +852 2199 4600  
Fax +852 2369 0796  
manfred.baerle@  
groz-beckert.com

### India

#### Neel Kamal

55, 1st Floor S.V. Complex,  
K.R. Road, Basavanagudi  
560 004 Bangalore  
Tel. +91 80 26624006  
Fax +91 80 26620400  
info@megagroup.co.in

### South Korea

#### NUMACS Co., Ltd.

101 dong 807 ho,  
Bucheon Technopark 1 Danji,  
#364 Samjung-Dong, Ojung-Gu,  
421-740 Bucheon-City,  
Gyeonggi-Do, S. Korea  
Tel. +82 324618110  
Fax +82 324618112  
info@numacs.co.kr

### Taiwan

#### Groz-Beckert (Taiwan) Ltd.

5F No. 202, Sec.2 Yanping N.Rd.  
Datong District, Taipei City 103  
Tel. +886 2 25531608  
Fax +886 2 25531628  
contact\_gbt@groz-beckert.com

You will find more information on our products and service, training and the latest company developments on our website.

[www.franke-gmbh.com](http://www.franke-gmbh.com)



Franke GmbH  
Obere Bahnstraße 64  
73431 Aalen, Germany  
Tel. +49 7361 920-0  
Fax +49 7361 920-120  
info@franke-gmbh.de  
www.franke-gmbh.com

┌

┐

└

┘

**Certified in accordance with**  
**ISO 9001**  
**ISO 14001**