

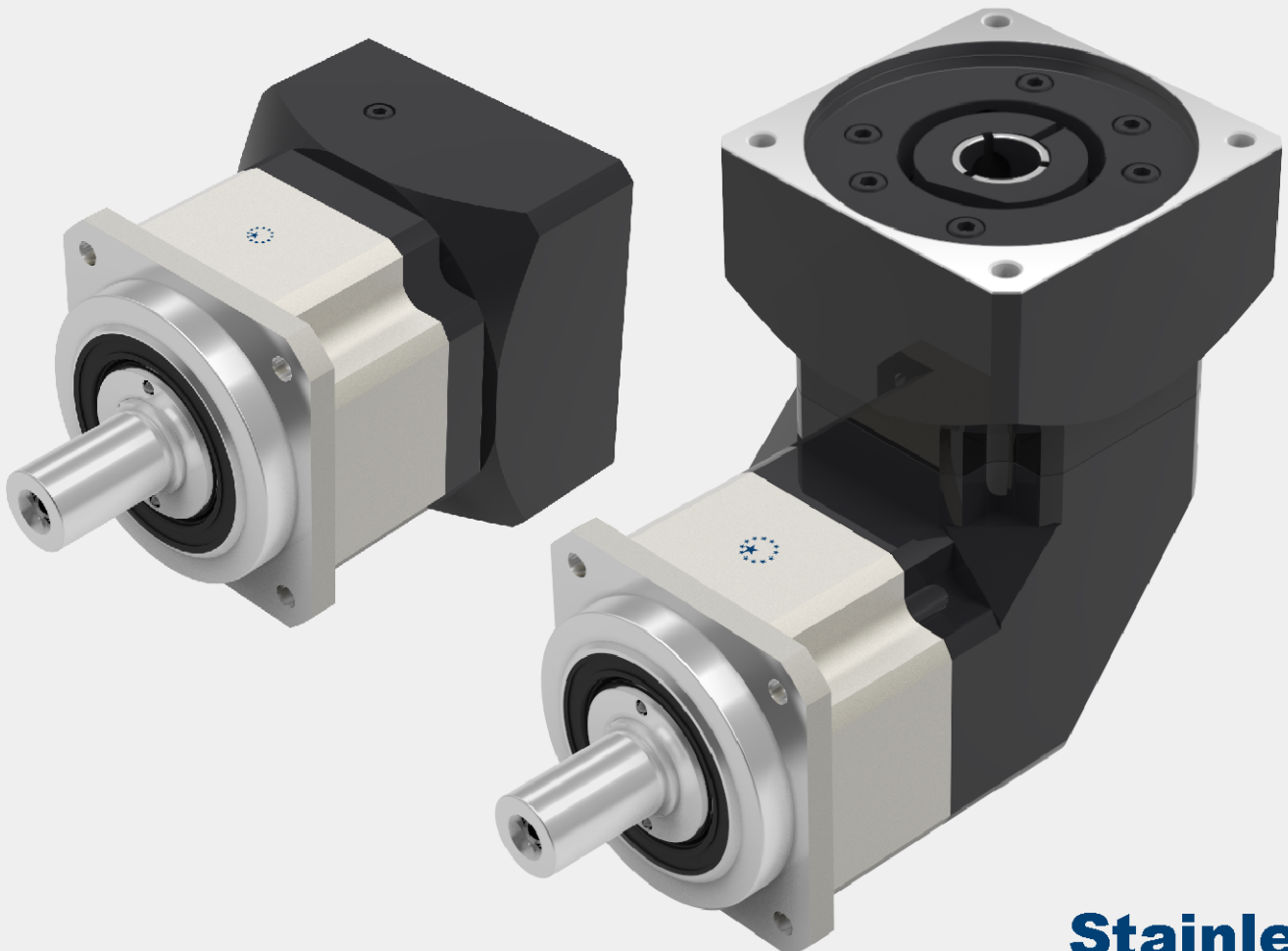

**APEX DYNAMICS, INC.**

**HIGH PRECISION  
PLANETARY GEARBOX**

**AB / ABR Series**



**Stainless**



**Apex Dynamics, Inc.** is the world's most productive manufacturer of servomotor drive planetary gearboxes for precision automation machinery. From our 800,000+ square foot ISO 9001:2008 manufacturing facility, based in Taichung, Taiwan, we manufacture to stock using the newest precision machine tools and quality test and inspection equipment. Complete focus on quality and precision allows us to produce our high quality gearheads at precision levels down to less than 1 arc minute (1/60 th of a degree), with consistency and high reliability.

Based on more than twenty years of accumulated manufacturing and marketing experience, plus the highest level of technical production capabilities, Apex Dynamics, Inc. designs and builds technically advanced, high speed, low backlash servo application planetary gearboxes. Our Break through patented technology (over 6 patents), provides the customer with the optimum high precision helical reducer at a reasonable price. We are continuously improving processes, finding proper and effective methods to provide customers new solutions for difficult applications, and developing new products.

The primary focus in daily operation is quality. We pride ourselves on our dedication to quality; our duty - is customer satisfaction.

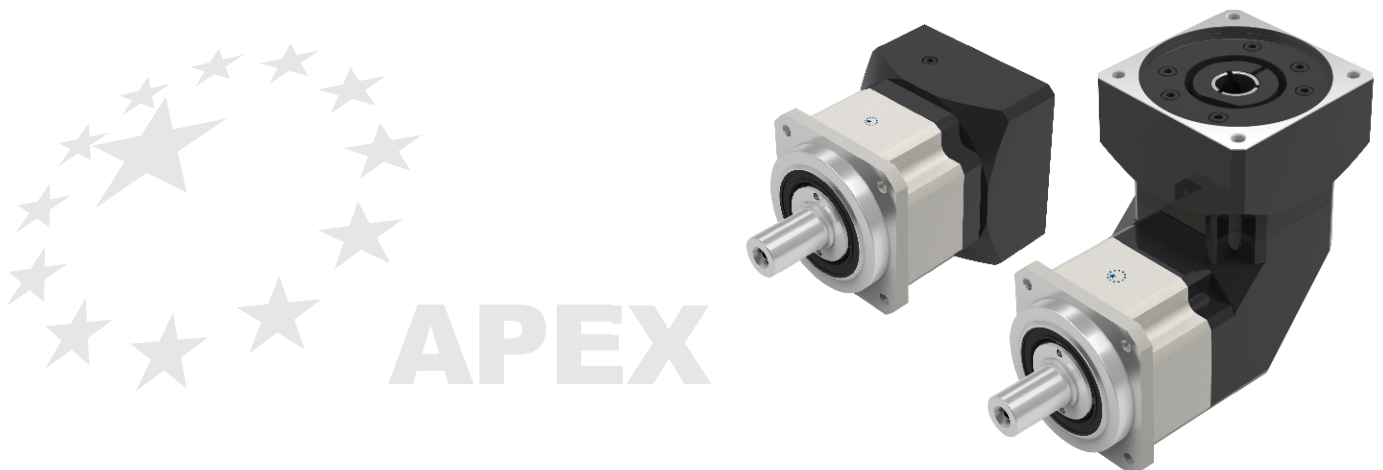

# AB Series

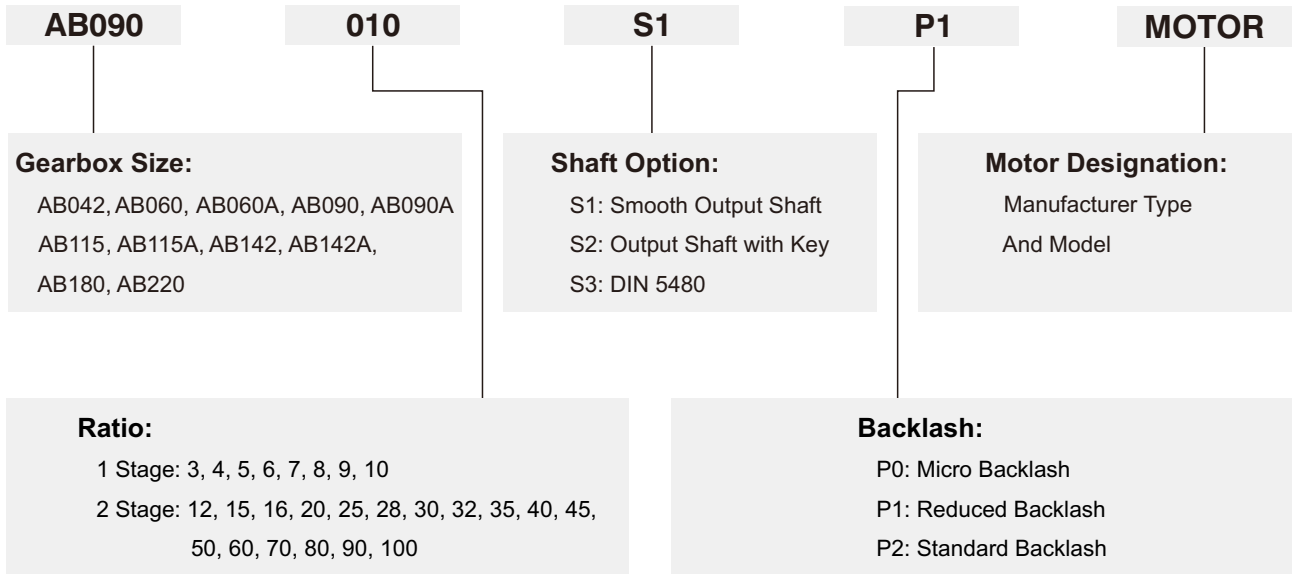

**Ordering Example: AB090-010-S1-P1 / SIEMENS 1FT6 041-4AF71**

# ABR Series

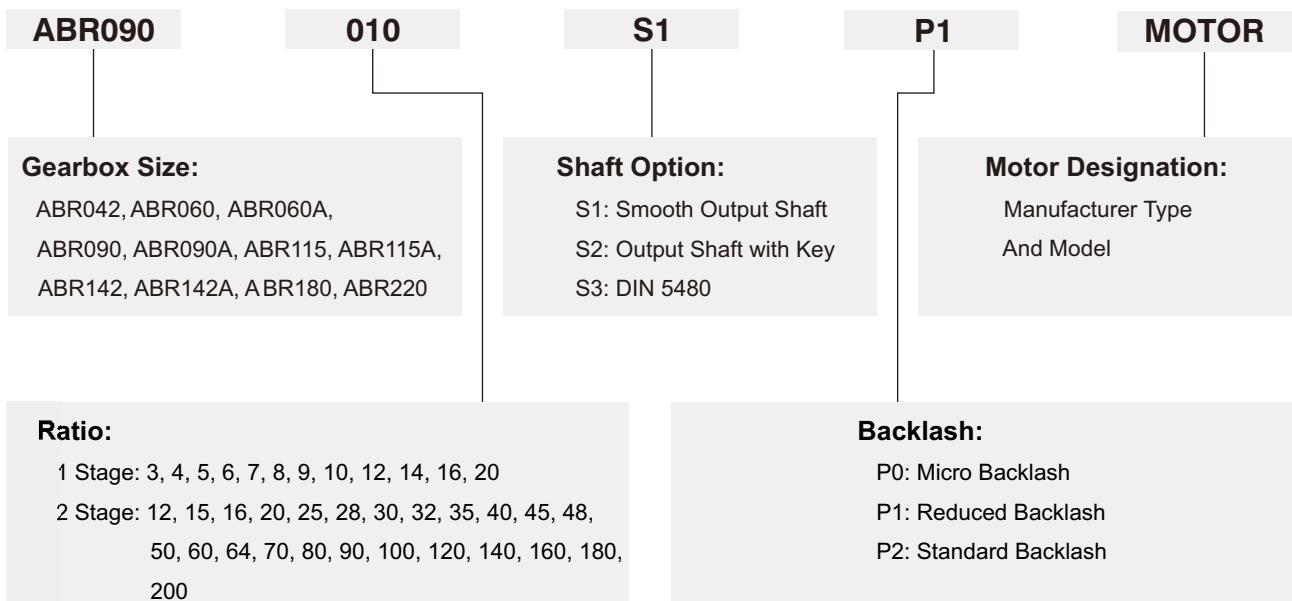

**Ordering Example: ABR090-010-S1-P1 / SIEMENS 1FT6 041-4AF71**

# Specifications / AB Series

## Gearbox Performance

Model No.	Stage	Ratio <sup>A</sup>	AB042	AB060	AB060A	AB090	AB090A	AB115	AB115A	AB142	AB142A	AB180	AB220	
Nominal Output Torque $T_{2N}$	1	3	20	55	-	130	-	208	-	342	-	588	1,140	
		4	19	50	-	140	-	290	-	542	-	1,050	1,700	
		5	22	60	-	160	-	330	-	650	-	1,200	2,000	
		6	20	55	-	150	-	310	-	600	-	1,100	1,900	
		7	19	50	-	140	-	300	-	550	-	1,100	1,800	
		8	17	45	-	120	-	260	-	500	-	1,000	1,600	
		9	14	40	-	100	-	230	-	450	-	900	1,500	
		10	14	40	-	100	-	230	-	450	-	900	1,500	
		2	12	19	50	50	140	140	290	290	542	542	1,050	1,700
			15	20	55	55	130	130	208	208	342	342	588	1,140
	16		19	50	50	140	140	290	290	542	542	1,050	1,700	
	20		19	50	50	140	140	290	290	542	542	1,050	1,700	
	25		22	60	60	160	160	330	330	650	650	1,200	2,000	
	28		19	50	50	140	140	300	300	550	550	1,100	1,800	
	30		20	55	55	150	150	310	310	600	600	1,100	1,900	
	32		17	45	45	120	120	260	260	500	500	1,000	1,600	
	35		19	50	50	140	140	300	300	550	550	1,100	1,800	
	40		17	45	45	120	120	260	260	500	500	1,000	1,600	
	45	14	40	40	100	100	230	230	450	450	900	1,500		
	50	22	60	60	160	160	330	330	650	650	1,200	2,000		
60	20	55	55	150	150	310	310	600	600	1,100	1,900			
70	19	50	50	140	140	300	300	550	550	1,100	1,800			
80	17	45	45	120	120	260	260	500	500	1,000	1,600			
90	14	40	40	100	100	230	230	450	450	900	1,500			
100	14	40	40	100	100	230	230	450	450	900	1,500			
Emergency Stop Torque $T_{2NOT}$ <sup>B</sup>	Nm	1,2	3~100	3 times of Nominal Output Torque										
Nominal Input Speed $n_{1N}$	rpm	1,2	3~100	5,000	5,000	5,000	4,000	4,000	4,000	4,000	3,000	3,000	3,000	2,000
Max. Input Speed $n_{1B}$	rpm	1,2	3~100	10,000	10,000	10,000	8,000	8,000	8,000	8,000	6,000	6,000	6,000	4,000
Micro Backlash P0	arcmin	1	3~10	-	-	-	≤1	-	≤1	-	≤1	-	≤1	≤1
		2	12~100	-	-	-	-	-	≤3	≤3	≤3	≤3	≤3	≤3
Reduced Backlash P1	arcmin	1	3~10	≤3	≤3	-	≤3	-	≤3	-	≤3	-	≤3	≤3
		2	12~100	≤5	≤5	≤5	≤5	≤5	≤5	≤5	≤5	≤5	≤5	≤5
Standard Backlash P2	arcmin	1	3~10	≤5	≤5	-	≤5	-	≤5	-	≤5	-	≤5	≤5
		2	12~100	≤7	≤7	≤7	≤7	≤7	≤7	≤7	≤7	≤7	≤7	≤7
Torsional Rigidity	Nm/arcmin	1,2	3~100	3	7	7	14	14	25	25	50	50	145	225
Max. Radial Load $F_{2B}^C$	N	1,2	3~100	780	1,530	1,530	3,250	3,250	6,700	6,700	9,400	9,400	14,500	50,000
Max. Axial Load $F_{2aB}^C$	N	1,2	3~100	390	765	765	1,625	1,625	3,350	3,350	4,700	4,700	7,250	25,000
Service Life <sup>D</sup>	hr	1,2	3~100	20,000										
Efficiency $\eta$	%	1	3~10	≥97%										
		2	12~100	≥94%										
Weight	kg	1	3~10	0.6	1.3	-	3.7	-	7.8	-	14.5	-	29	48
		2	12~100	0.8	1.5	1.9	4.1	5.3	9	11.4	17.5	20.7	33	60
Operating Temp	°C	1,2	3~100	-10°C~90°C										
Lubrication		1,2	3~100	Synthetic lubrication oils										
Degree of Gearbox Protection		1,2	3~100	IP65										
Mounting Position		1,2	3~100	all directions										
Noise ( $n_1=3000$ rpm, $i=10$ , No load) <sup>E</sup>	dB(A)	1,2	3~100	≤56	≤58	≤60	≤60	≤63	≤63	≤65	≤65	≤67	≤67	≤70

A. Ratio ( $i=N_{in}/N_{out}$ )B. Max. acceleration torque  $T_{2B}$  = 60% of  $T_{2NOT}$ 

C. Applied to the output shaft center at 100 rpm

D. For continuous operation, the service life time is less than 10,000 hrs

E. These values are measured by gearbox with ratio = 10 (1-stage) or ratio = 100 (2-stage) at 3,000 rpm no loading.

By lower ratio and/or higher RPM, the noise level could be 3 to 5 dB higher

# Ordering Code

## Gearbox Inertia

Model No.	Stage	Ratio	AB042	AB060	AB060A	AB090	AB090A	AB115	AB115A	AB142	AB142A	AB180	AB220	
Mass Moments of Inertia $J_1$	1	3	0.03	0.16	-	0.61	-	3.25	-	9.21	-	28.98	69.61	
		4	0.03	0.14	-	0.48	-	2.74	-	7.54	-	23.67	54.37	
		5	0.03	0.13	-	0.47	-	2.71	-	7.42	-	23.29	53.27	
		6	0.03	0.13	-	0.45	-	2.65	-	7.25	-	22.75	51.72	
		7	0.03	0.13	-	0.45	-	2.62	-	7.14	-	22.48	50.97	
		8	0.03	0.13	-	0.44	-	2.58	-	7.07	-	22.59	50.84	
		9	0.03	0.13	-	0.44	-	2.57	-	7.04	-	22.53	50.63	
		10	0.03	0.13	-	0.44	-	2.57	-	7.03	-	22.51	50.56	
		12	0.03	0.03	0.16	0.16	0.61	0.61	3.25	3.25	9.21	9.21	28.98	69.61
		15	0.03	0.03	0.13	0.13	0.47	0.47	2.71	2.71	7.42	7.42	23.29	53.27
	16	0.03	0.03	0.14	0.14	0.48	0.48	2.74	2.74	7.54	7.54	23.67	54.37	
	20	0.03	0.03	0.13	0.13	0.47	0.47	2.71	2.71	7.42	7.42	23.29	53.27	
	25	0.03	0.03	0.13	0.13	0.47	0.47	2.71	2.71	7.42	7.42	23.29	53.27	
	28	0.03	0.03	0.14	0.14	0.48	0.48	2.74	2.74	7.54	7.54	23.67	54.37	
	30	0.03	0.03	0.13	0.13	0.47	0.47	2.71	2.71	7.42	7.42	23.29	53.27	
	32	0.03	0.03	0.14	0.14	0.48	0.48	2.74	2.74	7.54	7.54	23.67	54.37	
	35	0.03	0.03	0.13	0.13	0.47	0.47	2.71	2.71	7.42	7.42	23.29	53.27	
	40	0.03	0.03	0.13	0.13	0.47	0.47	2.71	2.71	7.42	7.42	23.29	53.27	
	45	0.03	0.03	0.13	0.13	0.47	0.47	2.71	2.71	7.42	7.42	23.29	53.27	
	50	0.03	0.03	0.13	0.13	0.44	0.44	2.57	2.57	7.03	7.03	22.51	50.56	
60	0.03	0.03	0.13	0.13	0.44	0.44	2.57	2.57	7.03	7.03	22.51	50.56		
70	0.03	0.03	0.13	0.13	0.44	0.44	2.57	2.57	7.03	7.03	22.51	50.56		
80	0.03	0.03	0.13	0.13	0.44	0.44	2.57	2.57	7.03	7.03	22.51	50.56		
90	0.03	0.03	0.13	0.13	0.44	0.44	2.57	2.57	7.03	7.03	22.51	50.56		
100	0.03	0.03	0.13	0.13	0.44	0.44	2.57	2.57	7.03	7.03	22.51	50.56		

# Dimensions (1-stage, Ratio $i=3\sim 10$ ) / AB Series

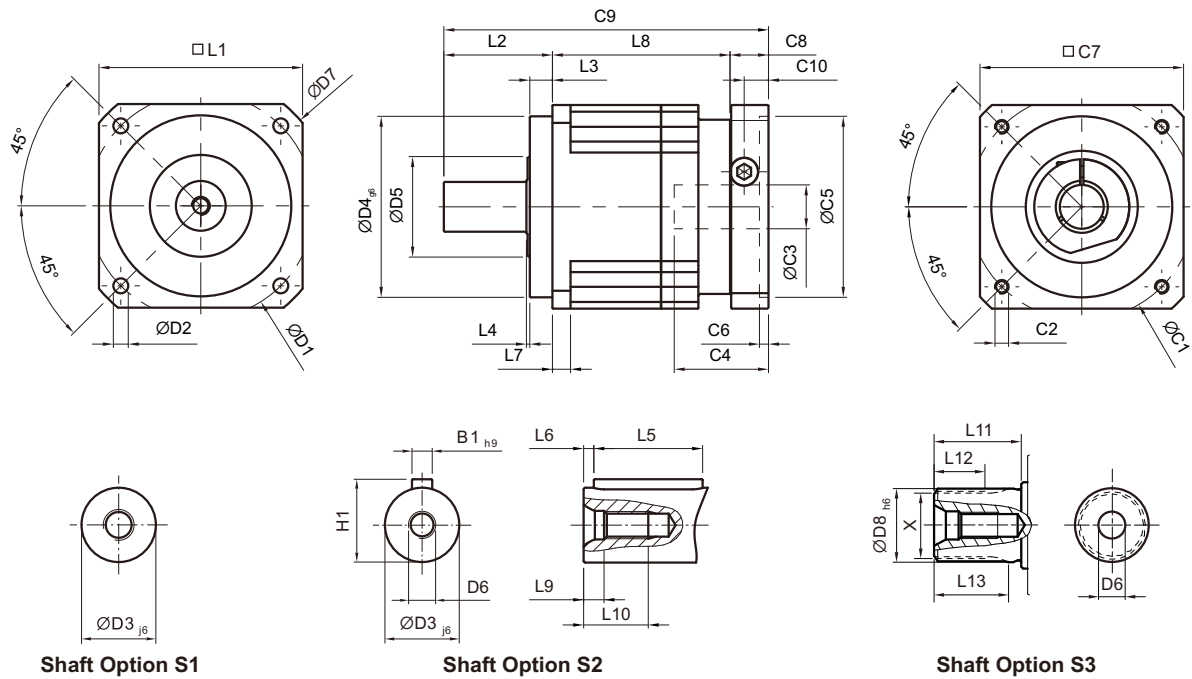

[unit: mm]

Dimension	AB042	AB060	AB090	AB115	AB142	AB180	AB220
D1	50	70	100	130	165	215	250
D2	3.4	5.5	6.6	9	11	13	17
D3 <sub>j6</sub>	13	16	22	32	40	55	75
D4 <sub>g6</sub>	35	50	80	110	130	160	180
D5	22	45	65	95	75	95	115
D6	M4 x 0.7P	M5 x 0.8P	M8 x 1.25P	M12 x 1.75P	M16 x 2P	M20 x 2.5P	M20 x 2.5P
D7	56	80	116	152	185	240	292
D8 <sub>h6</sub>	-	16	22	32	40	55	75
L1	42	60	90	115	142	180	220
L2	26	37	48	65	97	105	138
L3	5.5	7	10	12	15	20	30
L4	1	1.5	1.5	2	3	3	3
L5	16	25	32	40	63	70	90
L6	2	2	3	5	5	6	7
L7	4	6	8	10	12	15	20
L8	31	61	78.5	102	119.5	154	163.5
L9	4.5	4.8	7.2	10	12	15	15
L10	10	12.5	19	28	36	42	42
L11	-	26	26	26	40	41.5	52
L12	-	15	15	15	20	21.5	28
L13	-	21	22.5	23	33.5	33.5	45
C1 <sup>1</sup>	46	70	100	130	165	215	235
C2 <sup>1</sup>	M4 x 0.7P	M5 x 0.8P	M6 x 1P	M8 x 1.25P	M10 x 1.5P	M12 x 1.75P	M12 x 1.75P
C3 <sup>1</sup>	≤11 / ≤12 <sup>2</sup>	≤14 / ≤16 <sup>2</sup>	≤19 / ≤24	≤32	≤38	≤48	≤55
C4 <sup>1</sup>	25	34	40	50	60	85	116
C5 <sup>1</sup>	30	50	80	110	130	180	200
C6 <sup>1</sup>	3.5	8	4	5	6	6	6
C7 <sup>1</sup>	42	60	90	115	142	190	220
C8 <sup>1</sup>	29.5	19	17	19.5	22.5	29	63
C9 <sup>1</sup>	86.5	117	143.5	186.5	239	288	364.5
C10 <sup>1</sup>	8.75	13.5	10.75	13	15	20.75	53
B1 <sub>h9</sub>	5	5	6	10	12	16	20
H1	15	18	24.5	35	43	59	79.5
X DIN5480	-	W16x0.8x 30x18x6m	W22x1.25x 30x16x6m	W32x1.25x 30x24x6m	W40x2x 30x18x6m	W55x2x 30x26x6m	W70x2x 30x34x6m

1. C1-C10 are motor specific dimensions (metric std shown). Refer to [www.apexdyna.com](http://www.apexdyna.com) and Design Tool to view your specific motor mounting system.  
 2. AB042 ratio 5, 10 offers C3 ≤ 12 option; AB060 ratio 5, 10 offers C3 ≤ 16 option.

# Dimensions (2-stage, Ratio $i=12\sim 100$ ) / AB Series

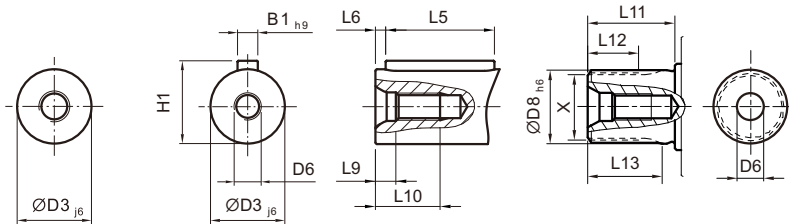
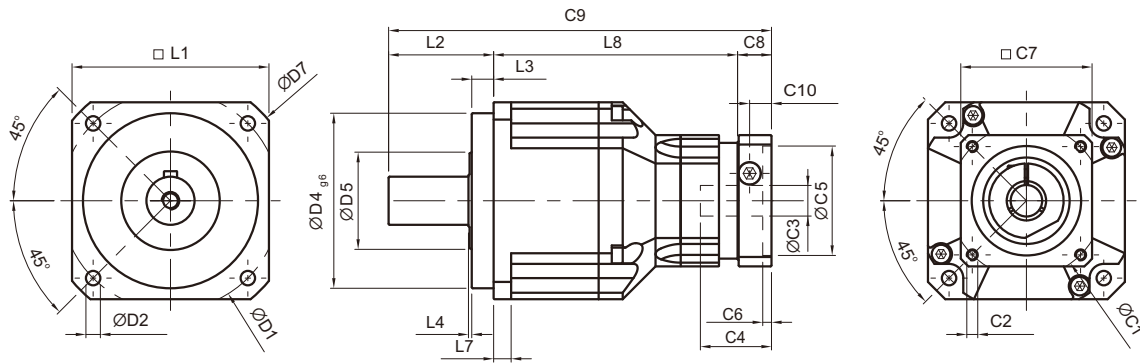

Shaft Option S1

Shaft Option S2

Shaft Option S3

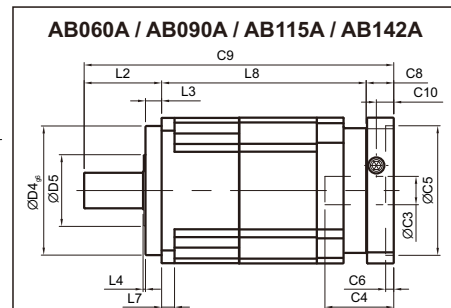

[unit: mm]

Dimension	AB042	AB060	AB060A	AB090	AB090A	AB115	AB115A	AB142	AB142A	AB180	AB220
D1	50	70		100		130		165	215	250	
D2	3.4	5.5		6.6		9		11	13	17	
D3 <sub>j6</sub>	13	16		22		32		40	55	75	
D4 <sub>g6</sub>	35	50		80		110		130	160	180	
D5	22	45		65		95		75	95	115	
D6	M4x0.7P	M5 x 0.8P		M8 x 1.25P		M12x1.75P		M16 x 2P	M20x2.5P	M20x2.5P	
D7	56	80		116		152		185	240	292	
D8 <sub>h6</sub>	-	16		22		32		40	55	75	
L1	42	60		90		115		142	180	220	
L2	26	37		48		65		97	105	138	
L3	5.5	7		10		12		15	20	30	
L4	1	1.5		1.5		2		3	3	3	
L5	16	25		32		40		63	70	90	
L6	2	2		3		5		5	6	7	
L7	4	6		8		10		12	15	20	
L8	58.5	72	98	111.5	126.5	143.5	163	176	191	209.5	248
L9	4.5	4.8		7.2		10		12	15	15	
L10	10	12.5		19		28		36	42	42	
L11	-	26		26		26		40	41.5	52	
L12	-	15		15		15		20	21.5	28	
L13	-	21		22.5		23		33.5	33.5	45	
C1 <sup>3</sup>	46	46	70	70	100	100	130	130	165	165	215
C2 <sup>3</sup>	M4x0.7P	M4x0.7P	M5 x 0.8P	M5 x 0.8P	M6 x 1P	M6 x 1P	M8x1.25P	M8x1.25P	M10x1.5P	M10x1.5P	M12x1.75P
C3 <sup>3</sup>	≤11 / ≤12	≤11 / ≤12	≤14 / ≤16	≤14 / ≤15.875 / ≤16	≤19 / ≤24	≤19 / ≤24	≤32	≤32	≤38	≤38	≤48
C4 <sup>3</sup>	25	25	34	34	40	40	50	50	60	60	85
C5 <sup>3</sup>	30	30	50	50	80	80	110	110	130	130	180
C6 <sup>3</sup>	3.5	3.5	8	8	4	4	5	5	6	6	6
C7 <sup>3</sup>	42	42	60	60	90	90	115	115	142	142	190
C8 <sup>3</sup>	29.5	29.5	19	19	17	17	19.5	19.5	22.5	22.5	29
C9 <sup>3</sup>	114	138.5	154	178.5	191.5	225.5	247.5	292.5	310.5	337	415
C10 <sup>3</sup>	8.75	8.75	13.5	13.5	10.75	10.75	13	13	15	15	20.75
B1 <sub>h9</sub>	5	5		6		10		12	16	20	
H1	15	18		24.5		35		43	59	79.5	
X DIN5480	-	W16x0.8x 30x18x6m		W22x1.25x 30x16x6m		W32x1.25x 30x24x6m		W40x2x 30x18x6m	W55x2x 30x26x6m	W70x2x 30x34x6m	

3. C1~C10 are motor specific dimensions (metric std shown). Refer to [www.apexdyna.com](http://www.apexdyna.com) and Design Tool to view your specific motor mounting system.

# Specifications / ABR Series

## Gearbox Performance

Model No.		Stage	Ratio <sup>A</sup>	ABR042	ABR060	ABR060A	ABR090	ABR090A	ABR115	ABR115A	ABR142	ABR142A	ABR180	ABR220	
Nominal Output Torque T <sub>2N</sub>	Nm	1	3	9	36	-	90	-	195	-	342	-	588	1,140	
			4	12	48	-	120	-	260	-	520	-	1,040	1,680	
			5	15	60	-	150	-	325	-	650	-	1,200	2,000	
			6	18	55	-	150	-	310	-	600	-	1,100	1,900	
			7	19	50	-	140	-	300	-	550	-	1,100	1,800	
			8	17	45	-	120	-	260	-	500	-	1,000	1,600	
			9	14	40	-	100	-	230	-	450	-	900	1,500	
			10	14	60	-	150	-	325	-	650	-	1,200	2,000	
			12	-	55	-	150	-	310	-	600	-	1,100	1,900	
			14	-	42	-	140	-	300	-	550	-	1,100	1,800	
		16	-	45	-	120	-	260	-	500	-	1,000	1,600		
		20	-	40	-	100	-	230	-	450	-	900	1,500		
		2	12	12	-	-	-	-	-	-	-	-	-	-	-
			15	14	-	-	-	-	-	-	-	-	-	-	-
			16	15	-	-	-	-	-	-	-	-	-	-	-
			20	14	-	-	-	-	-	-	-	-	-	-	-
			25	15	60	60	150	150	325	325	650	650	1,200	2,000	
			28	19	50	50	140	140	300	300	550	550	1,100	1,800	
			30	20	55	55	150	150	310	310	600	600	1,100	1,900	
			32	17	45	45	120	120	260	260	500	500	1,000	1,600	
			35	19	50	50	140	140	300	300	550	550	1,100	1,800	
			40	17	45	45	120	120	260	260	500	500	1,000	1,600	
			45	14	40	40	100	100	230	230	450	450	900	1,500	
			48	-	-	55	150	150	310	310	600	600	1,100	1,900	
			50	14	60	60	100	100	230	230	650	650	1,200	2,000	
			60	20	55	55	150	150	310	310	600	600	1,100	1,900	
			64	-	-	45	120	120	260	260	500	500	1,000	1,600	
			70	19	50	50	140	140	300	300	550	550	1,100	1,800	
			80	17	45	45	120	120	260	260	500	500	1,000	1,600	
			90	14	40	40	100	100	230	230	450	450	900	1,500	
100	14		40	60	150	150	325	325	650	650	1,200	2,000			
120	-		-	55	150	150	310	310	600	600	1,100	1,900			
140	-	-	50	140	140	300	300	550	550	1,100	1,800				
160	-	-	45	120	120	260	260	500	500	1,000	1,600				
180	-	-	40	100	100	230	230	450	450	900	1,500				
200	-	-	40	100	100	230	230	450	450	900	1,500				
Emergency Stop Torque T <sub>2NOT</sub> <sup>B</sup>	Nm	1,2	3~200	3 times of Nominal Output Torque											
Nominal Input Speed n <sub>1N</sub>	rpm	1,2	3~200	5,000	5,000	5,000	4,000	4,000	4,000	4,000	3,000	3,000	3,000	2,000	
Max. Input Speed n <sub>1B</sub>	rpm	1,2	3~200	10,000	10,000	10,000	8,000	8,000	8,000	8,000	6,000	6,000	6,000	4,000	
Micro Backlash P0	arcmin	1	3~20	-	-	-	≤2	-	≤2	-	≤2	-	≤2	≤2	
		2	12~200	-	-	-	≤4	≤4	≤4	≤4	≤4	≤4	≤4	≤4	
Reduced Backlash P1	arcmin	1	3~20	≤4	≤4	-	≤4	-	≤4	-	≤4	-	≤4	≤4	
		2	12~200	≤7	≤7	≤7	≤7	≤7	≤7	≤7	≤7	≤7	≤7	≤7	
Standard Backlash P2	arcmin	1	3~20	≤6	≤6	-	≤6	-	≤6	-	≤6	-	≤6	≤6	
		2	12~200	≤9	≤9	≤9	≤9	≤9	≤9	≤9	≤9	≤9	≤9	≤9	
Torsional Rigidity	Nm/arcmin	1,2	3~200	3	7	7	14	14	25	25	50	50	145	225	
Max. Radial Load F <sub>2rB</sub> <sup>C</sup>	N	1,2	3~200	780	1,530	1,530	3,250	3,250	6,700	6,700	9,400	9,400	14,500	50,000	
Max. Axial Load F <sub>2aB</sub> <sup>C</sup>	N	1,2	3~200	390	765	765	1,625	1,625	3,350	3,350	4,700	4,700	7,250	25,000	
Service Life <sup>D</sup>	hr	1,2	3~200	20,000											
Efficiency η	%	1	3~20	≥95%											
		2	12~200	≥92%											
Weight	kg	1	3~20	0.9	2.1	-	6.4	-	13	-	24.5	-	51	83	
		2	12~200	1.2	1.5	2.7	7.8	7.9	14.2	15.9	27.5	29.6	54	95	
Operating Temp	°C	1,2	3~200	-10°C~+90°C											
Lubrication		1,2	3~200	Synthetic lubrication oils											
Degree of Gearbox Protection		1,2	3~200	IP65											
Mounting Position		1,2	3~200	all directions											
Noise (n <sub>1</sub> =3000rpm, i=10, No load) <sup>E</sup>	dB(A)	1,2	3~200	≤61	≤63	≤65	≤65	≤68	≤68	≤70	≤70	≤72	≤72	≤74	

A. Ratio (i=N<sub>in</sub>/N<sub>out</sub>)

B. Max. acceleration torque T<sub>2B</sub> = 60% of T<sub>2NOT</sub>

C. Applied to the output shaft center at 100 rpm

D. For continuous operation, the service life time is less than 10,000 hrs

E. These values are measured by gearbox with ratio = 10 (1-stage) or ratio = 100 (2-stage) at 3,000 rpm no loading.

By lower ratio and/or higher RPM, the noise level could be 3 to 5 dB higher



## Gearbox Inertia

Model No.		Stage	Ratio	ABR042	ABR060	ABR060A	ABR090	ABR090A	ABR115	ABR115A	ABR142	ABR142A	ABR180	ABR220	
Mass Moments of Inertia $J_i$	kg · cm <sup>2</sup>	1	3~10	0.09	0.35	–	2.25	–	6.84	–	23.4	–	68.9	135.4	
			12~20	–	0.07	–	1.87	–	6.25	–	21.8	–	65.6	119.8	
		2	12~20	0.09	–	–	–	–	–	–	–	–	–	–	–
			25~90	0.09	0.09	0.35	0.35	2.25	2.25	6.84	6.84	23.4	23.4	68.9	68.9
			48, 64	–	–	0.07	0.31	1.87	1.87	6.25	6.25	21.8	21.8	65.6	65.6
			100~200	–	–	0.07	0.31	1.87	1.87	6.25	6.25	21.8	21.8	65.6	65.6

# Dimensions (1-stage, Ratio $i=3\sim 20$ ) / ABR Series

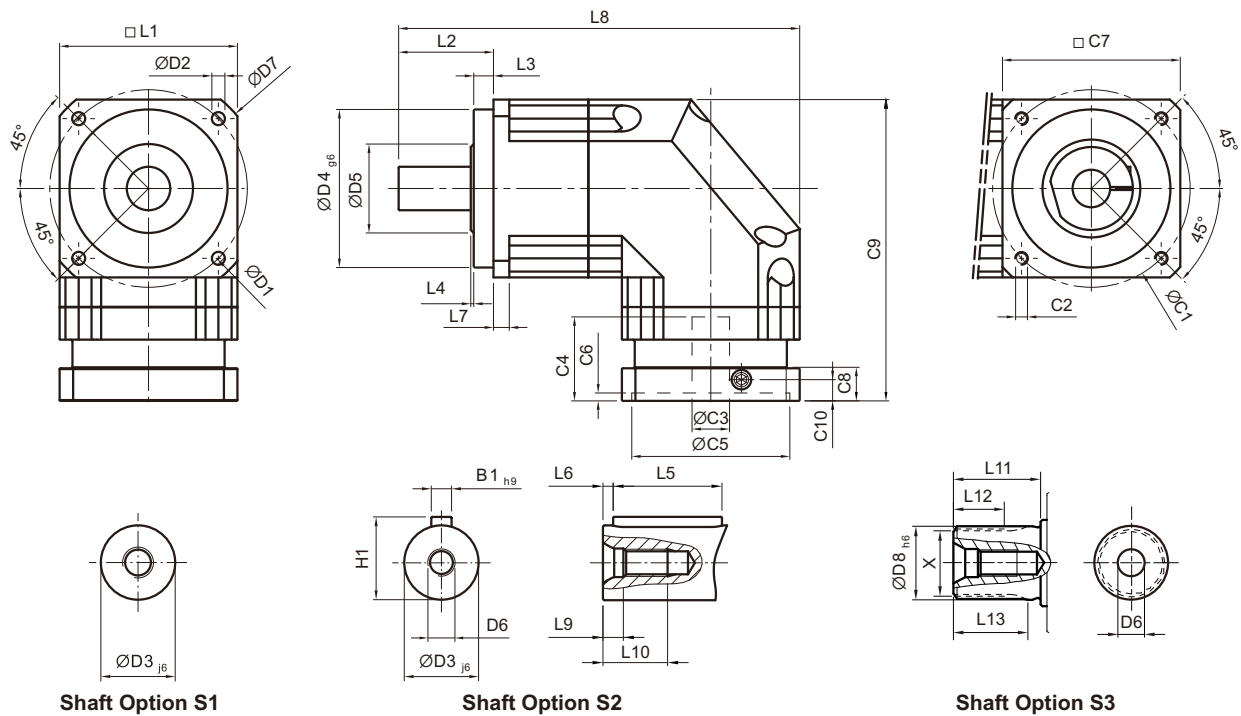

[unit: mm]

Dimension	ABR042	ABR060	ABR090	ABR115	ABR142	ABR180	ABR220
D1	50	70	100	130	165	215	250
D2	3.4	5.5	6.6	9	11	13	17
D3 j6	13	16	22	32	40	55	75
D4 g6	35	50	80	110	130	160	180
D5	22	45	65	95	75	95	115
D6	M4 x 0.7P	M5 x 0.8P	M8 x 1.25P	M12 x 1.75P	M16 x 2P	M20 x 2.5P	M20 x 2.5P
D7	56	80	116	152	185	240	292
D8 h6	-	16	22	32	40	55	75
L1	42	60	90	115	142	180	220
L2	26	37	48	65	97	105	138
L3	5.5	7	10	12	15	20	30
L4	1	1.5	1.5	2	3	3	3
L5	16	25	32	40	63	70	90
L6	2	2	3	5	5	6	7
L7	4	6	8	10	12	15	20
L8	111.5	145	203	259	333	394	484
L9	4.5	4.8	7.2	10	12	15	15
L10	10	12.5	19	28	36	42	42
L11	-	26	26	26	40	41.5	52
L12	-	15	15	15	20	21.5	28
L13	-	21	22.5	23	33.5	33.5	45
C1 <sup>1</sup>	46	70	100	130	165	215	235
C2 <sup>1</sup>	M4 x 0.7P	M5 x 0.8P	M6 x 1P	M8 x 1.25P	M10 x 1.5P	M12 x 1.75P	M12 x 1.75P
C3 <sup>1</sup>	≤11 / ≤12	≤14 / ≤16	≤19 / ≤24	≤32	≤38	≤48	≤55
C4 <sup>1</sup>	25	34	40	50	60	85	116
C5 <sup>1</sup>	30	50	80	110	130	180	200
C6 <sup>1</sup>	3.5	8	4	5	6	6	6
C7 <sup>1</sup>	42	60	90	115	142	190	220
C8 <sup>1</sup>	29.5	19	17	19.5	22.5	29	63
C9 <sup>1</sup>	90.5	111.5	152.5	191.5	235.5	303.5	378.5
C10 <sup>1</sup>	8.75	13.5	10.75	13	15	20.75	53
B1 h9	5	5	6	10	12	16	20
H1	15	18	24.5	35	43	59	79.5
X DIN5480	-	W16x0.8x 30x18x6m	W22x1.25x 30x16x6m	W32x1.25x 30x24x6m	W40x2x 30x18x6m	W55x2x 30x26x6m	W70x2x 30x34x6m

1. C1~C10 are motor specific dimensions (metric std shown). Refer to [www.apexdyna.com](http://www.apexdyna.com) and Design Tool to view your specific motor mounting system.

# Dimensions (2-stage, Ratio $i=12\sim 200$ ) / ABR Series

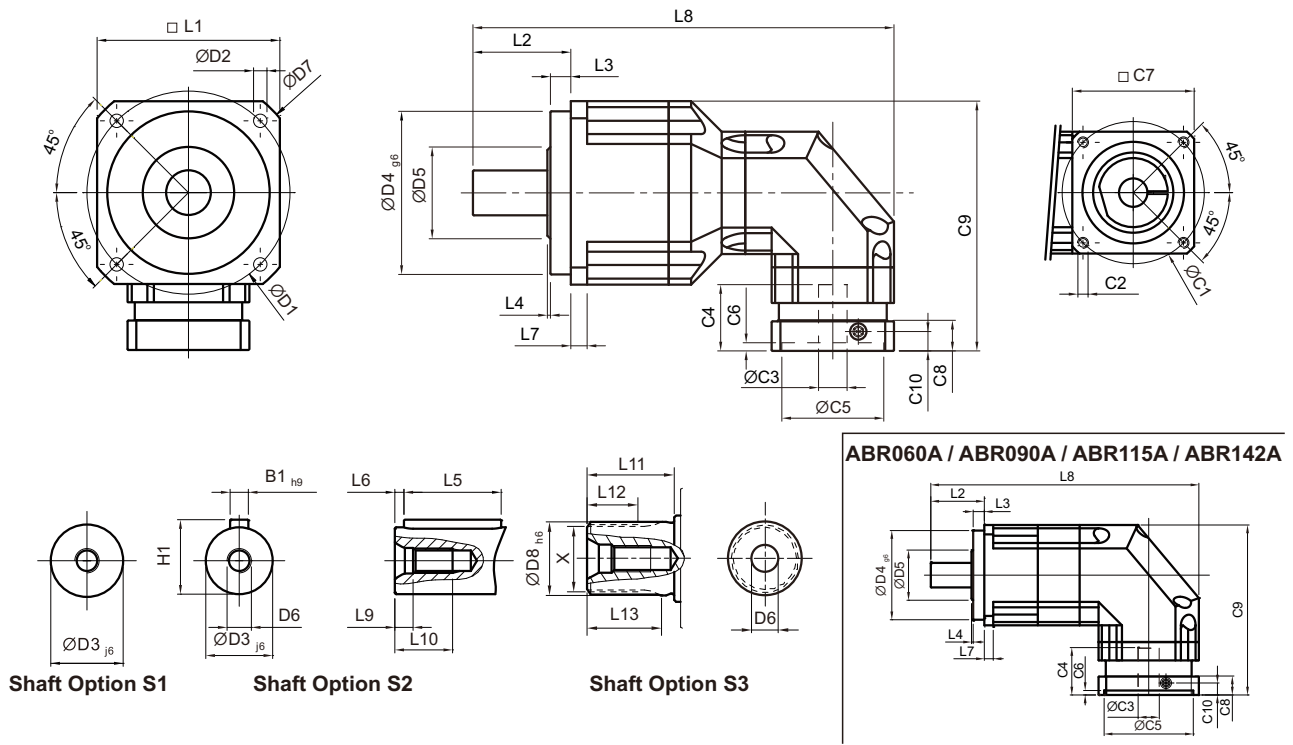

[unit: mm]

Dimension	ABR042	ABR060	ABR060A	ABR090	ABR090A	ABR115	ABR115A	ABR142	ABR142A	ABR180	ABR220
D1	50	70		100		130		165		215	250
D2	3.4	5.5		6.6		9		11		13	17
D3 <sub>j6</sub>	13	16		22		32		40		55	75
D4 <sub>g6</sub>	35	50		80		110		130		160	180
D5	22	45		65		95		75		95	115
D6	M4 x 0.7P	M5 x 0.8P		M8 x 1.25P		M12x1.75P		M16x2P		M20x2.5P	M20x2.5P
D7	56	80		116		152		185		240	292
D8 <sub>h6</sub>	-	16		22		32		40		55	75
L1	42	60		90		115		142		180	220
L2	26	37		48		65		97		105	138
L3	5.5	7		10		12		15		20	30
L4	1	1.5		1.5		2		3		3	3
L5	16	25		32		40		63		70	90
L6	2	2		3		5		5		6	7
L7	4	6		8		10		12		15	20
L8	139	163.5	182	206.5	251	285	320	365	404.5	431	521
L9	4.5	4.8		7.2		10		12		15	15
L10	10	12.5		19		28		36		42	42
L11	-	26		26		26		40		41.5	52
L12	-	15		15		15		20		21.5	28
L13	-	21		22.5		23		33.5		33.5	45
C1 <sup>2</sup>	46	46	70	70	100	100	130	130	165	165	215
C2 <sup>2</sup>	M4 x 0.7P	M4 x 0.7P	M5 x 0.8P	M5x0.8P	M6x1P	M6x1P	M8x1.25P	M8x1.25P	M10x1.5P	M10x1.5P	M12x1.75P
C3 <sup>2</sup>	≤11 / ≤12	≤11 / ≤12	≤14 / ≤16	≤14 / ≤15.875 / ≤16	≤19 / ≤24	≤19 / ≤24	≤32	≤32	≤38	≤38	≤48
C4 <sup>2</sup>	25	25	34	34	40	40	50	50	60	60	85
C5 <sup>2</sup>	30	30	50	50	80	80	110	110	130	130	180
C6 <sup>2</sup>	3.5	3.5	8	8	4	4	5	5	6	6	6
C7 <sup>2</sup>	42	42	60	60	90	90	115	115	142	142	190
C8 <sup>2</sup>	29.5	29.5	19	19	17	17	19.5	19.5	22.5	22.5	29
C9 <sup>2</sup>	90.5	99.5	111.5	126.5	152.5	165	191.5	205	235.5	254.5	323.5
C10 <sup>2</sup>	8.75	8.75	13.5	13.5	10.75	10.75	13	13	15	15	20.75
B1 <sub>h9</sub>	5	5		6		10		12		16	20
H1	15	18		24.5		35		43		59	79.5
X DIN5480	-	W16x0.8x 30x18x6m		W22x1.25x 30x16x6m		W32x1.25x 30x24x6m		W40x2x 30x18x6m		W55x2x 30x26x6m	W70x2x 30x34x6m

2. C1~C10 are motor specific dimensions (metric std shown). Refer to [www.apexdyna.com](http://www.apexdyna.com) and Design Tool to view your specific motor mounting system.

# Selection of the Optimum Gearbox

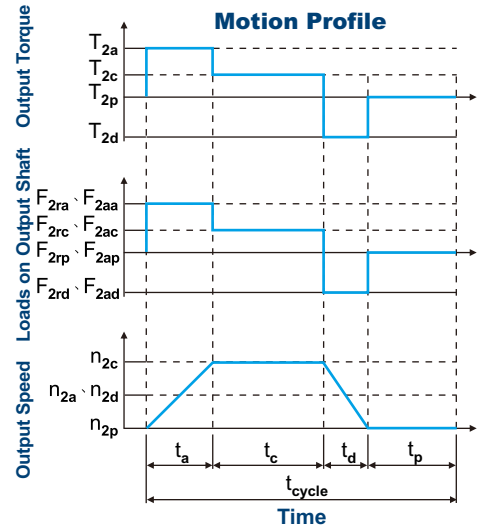
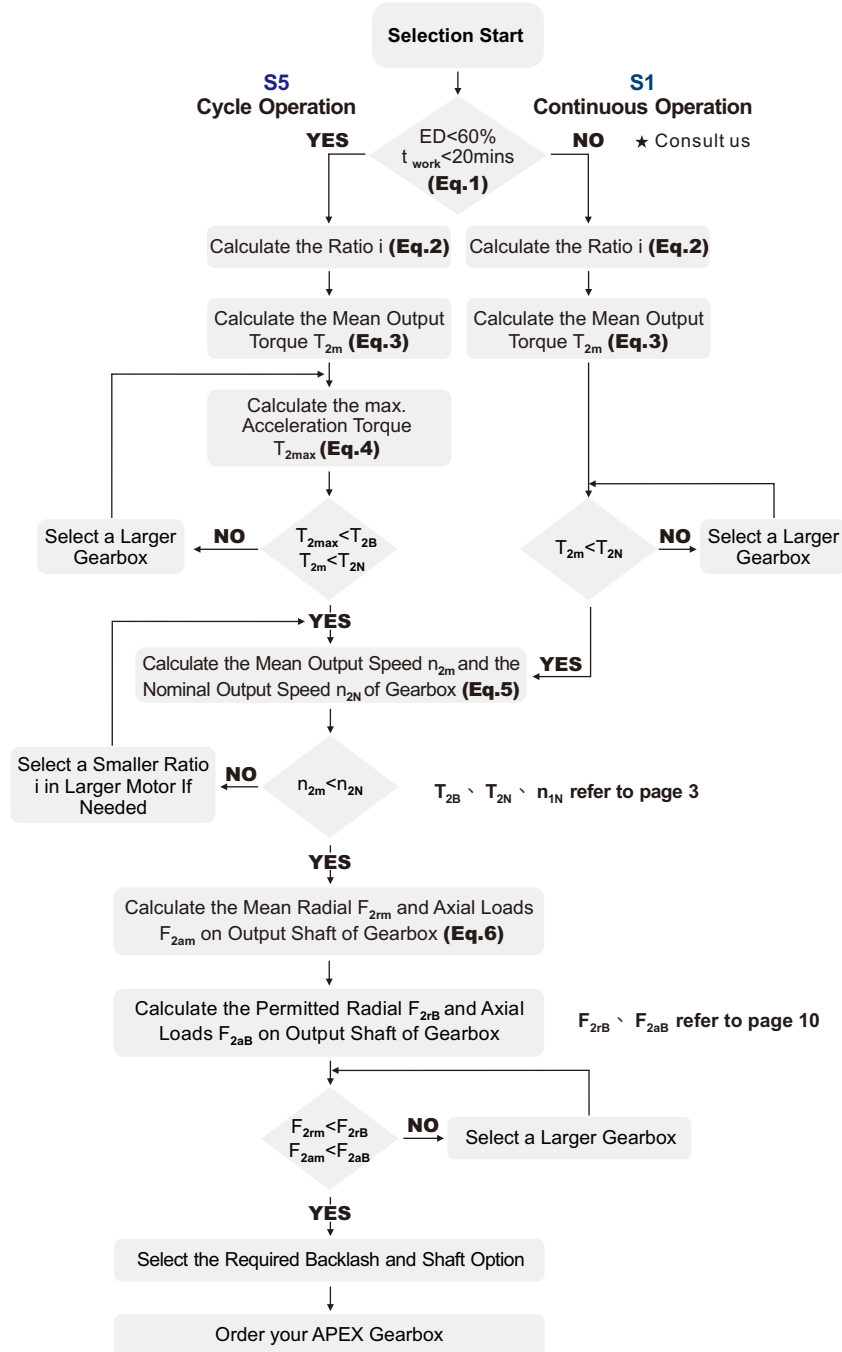

$$1. ED = \frac{t_a + t_c + t_d}{t_{cycle}} \times 100\%, t_{work} = t_a + t_c + t_d$$

Index : a. Acceleration, c. Constant, d. Deceleration, p. Pause (Eq.1)

$$2. i \cong \frac{n_m}{n_{work}}$$

$n_m$  Output Speed of the Motor  
 $n_{work}$  Working Speed (Eq.2)

$$3. T_{2m} = \sqrt[3]{\frac{n_{2a} \times t_a \times T_{2a}^3 + n_{2c} \times t_c \times T_{2c}^3 + n_{2d} \times t_d \times T_{2d}^3}{n_{2a} \times t_a + n_{2c} \times t_c + n_{2d} \times t_d}}$$

(Eq.3)

$$4. T_{2max} = T_{mB} \times i \times k_s \times \eta$$

where  $K_s$  is

$K_s$	No. of Cycles / hr
1.0	0 ~ 1,000
1.1	1,000 ~ 1,500
1.3	1,500 ~ 2,000
1.6	2,000 ~ 3,000
1.8	3,000 ~ 5,000

$T_{mB}$  Max. Output Torque of the Motor

$\eta$  Efficiency of the Gearbox (Eq.4)

$$5. n_{2a} = n_{2d} = \frac{1}{2} \times n_{2c}$$

$$n_{2m} = \frac{n_{2a} \times t_a + n_{2c} \times t_c + n_{2d} \times t_d}{t_a + t_c + t_d}$$

$$n_{2N} = \frac{n_{1N}}{i} \quad (Eq.5)$$

$$6. F_{2rm} = \sqrt[3]{\frac{n_{2a} \times t_a \times F_{2ra}^3 + n_{2c} \times t_c \times F_{2rc}^3 + n_{2d} \times t_d \times F_{2rd}^3}{n_{2a} \times t_a + n_{2c} \times t_c + n_{2d} \times t_d}}$$

$$F_{2am} = \sqrt[3]{\frac{n_{2a} \times t_a \times F_{2aa}^3 + n_{2c} \times t_c \times F_{2ac}^3 + n_{2d} \times t_d \times F_{2ad}^3}{n_{2a} \times t_a + n_{2c} \times t_c + n_{2d} \times t_d}} \quad (Eq.6)$$

## Recommended (for S5 Cycle Operation)

The general design is given for

$$\frac{J_L}{i^2} \leq 4 \times J_m$$

The optimal design is given for

$$\frac{J_L}{i^2} \cong J_m$$

$J_L$  Load Inertia

$J_m$  Motor Inertia

# Permitted Radial and Axial Loads

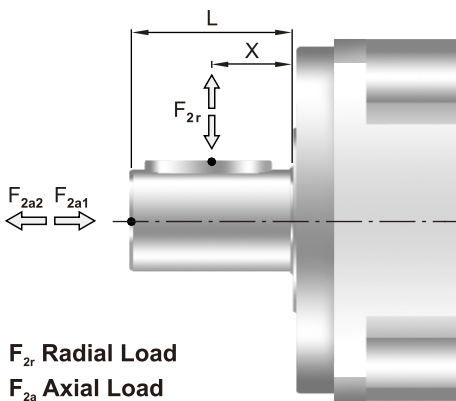

The permitted radial and axial loads on output shaft of the gearbox depend on the design of the gearbox supporting bearings. APEX use the extension straddle oversized ball bearing design. It can take heavy load from both axes.

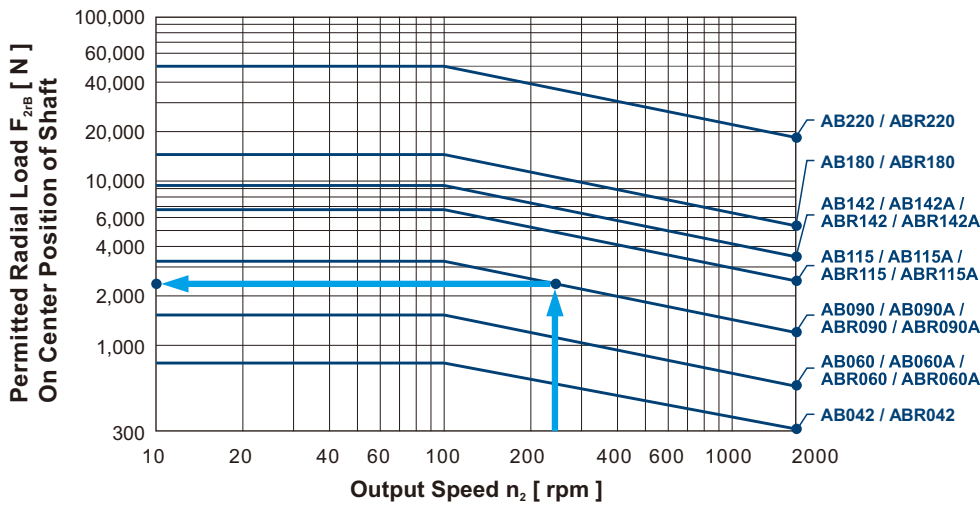

If radial force  $F_{2r}$  exert on the center of the output shaft  $X=1/2 \times L$ . Under various operating condition the lifetime is over 20,000\* hours. The permitted radial load is given on left diagram.

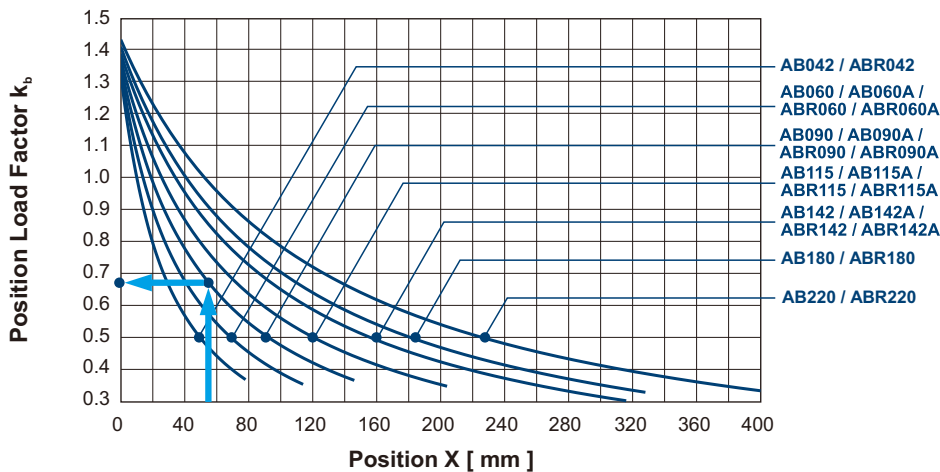

If radial force  $F_{2r}$  not exert on the center of the output shaft  $X < 1/2 \times L$  or  $X > 1/2 \times L$ . The permitted radial and axial load can be calculated by the position load factor  $K_b$  on the left diagram.

\* S1 service life 10,000 hrs



**APEX TAIWAN NORTH  
ANDTEK AUTOMATION CO.,LTD**  
TEL +886-02-82262655  
13F-5, No.2, Jian 8th Rd., Jhonghe Dist., New  
Taipei City 235, TAIWAN  
sales@andtek.com.tw  
www.apexdyna.com



**APEX TAIWAN CENTRAL  
ANDTEK AUTOMATION CO.,LTD**  
TEL +886-04-23594286  
9F-6, No.925, Sec.4, Taiwan Blvd., Xitun Dist.  
Taichung City 407 TAIWAN  
sales@andtek.com.tw  
www.apexdyna.com



**APEX TAIWAN SOUTH  
MEN JENN ELECTRIC CO., LTD.**  
TEL +886-06-2337332 ~ 6  
No.774, Zhonghua Rd., Yongkang Dist., Tainan  
City 710, TAIWAN  
menjenn@ms24.hinet.net  
www.apexdyna.com



**APEX DYNAMICS INC. SHANGHAI**  
TEL +86-21-69220577  
No.128 ZHUYING Road QINGPU Industry Area,  
Shanghai, CHINA  
sales@apexdyna.cn  
www.apexdyna.com



**APEX DYNAMICS SHENZHEN, LTD.**  
TEL +86-755-84516325  
No. 1102A of D area , CFG mansion ,Bao Yuan  
Road , Bao' an District , Shenzhen ,CHINA.  
sales@szapexdyna.com  
www.szapexdyna.com



**APEX DYNAMICS BEIJING, LTD.**  
TEL +86-10-69570691  
NO.1,YaoPingRoad,SongZhuang Town, Tongzhou  
istrict, Beijing, CHINA.  
bjapexdyna@163.com  
www.bjapex.cn



**CHONGQING APEX DYNAMICS CO., LTD.**  
TEL +86-23-67686860  
406, Building 5, No.68, Jinyu Avenue, Beibu New  
Area, Chongqing, CHINA  
sales@cqapexdyna.com  
www.apexdyna.com



**APEX (XIAMEN) DYNAMICS TECHNOLOGY CO., LTD.**  
TEL +86-0592-720-5279  
Unit B-3,1F.,No.129,Jingquan Road, Jimei District,  
Xiamen, Fujian, CHINA  
sales@xmapexdyna.com  
www.xmapexdyna.com



**APEX DYNAMICS USA, INC.**  
TEL +1-631-2449040  
885 Marconi Avenue Ronkonkoma, NY 11779  
U.S.A.  
sales@apexdynamicsusa.com  
www.apexdynamicsusa.com



**APEX DYNAMICS KOREA**  
TEL +82-31-8179992  
1246-32, Seongsuk-dong, Ilsandong-gu, Goyang-city,  
Gyeonggi-Do, KOREA (R.O.K) 410-570  
sales@apexdynakorea.co.kr  
www.apexdynakorea.co.kr



**APEX DYNAMICS JAPAN**  
TEL +81-092-4511202  
1-13-3, Sannou, Hakata-ku, Fukuoka-shi 812-0015,  
JAPAN  
sales@apexdyna.jp  
www.apexdyna.jp



**APEX DYNAMICS SINGAPORE PTE LTD**  
TEL +65-62-626228  
3 South Buona Vista Road, #05-15 & #06-15.  
SINGAPORE 118136  
sales@apexdyna.com.sg  
www.apexdyna.com.sg



**APEX DYNAMICS (THAILAND) CO., LTD.**  
TEL +66-2-3266233  
73 Soi Ladkrabang 30, Kadkrabang Rd.,Bangkok  
10520, THAILAND  
sales@apexdyna.co.th  
www.apexdyna.co.th



**APEX DYNAMICS BV**  
TEL +31-492-509995  
Churchillaan 101 5705 BK Helmond, NETHERLANDS  
sales@apexdyna.nl  
www.apexdyna.nl  
www.apexdyna.be



**APEX DYNAMICS  
POLSKA SP. Z O.O.**  
TEL +48-12-6304728  
Krakowska 50, 32-083 Balice, POLAND  
sales@apexdyna.pl  
www.apexdyna.pl



**APEX DYNAMICS SPAIN, S.L.**  
TEL +34-93-6562990  
Poligono Industrial Molí dels Frares, Calle C nº  
12,08620 - Sant Vicenç dels Horts, Barcelona, SPAIN  
apexdyna@apexdyna.es  
www.apexdyna.es



**APEX DYNAMICS IRAN.**  
TEL +98-21-66593517  
APT#6, 3rd Flr, No.5, 3rd Kowsar St., Sattarkhan  
Ave., Tehran, IRAN  
alahyari@farasysco.com  
www.apexdyna.ir



**APEKS REDUKTOR VE DISLI SAN. TIC. LTD. STI.**  
TEL +90-232-4589960  
10042 Sok.No:10 AOSB Çiğli-İzmir, TURKEY  
sales@apexdyna.com.tr  
www.apexdyna.com.tr



**APEX DYNAMICS AUSTRALIA PTY LTD.**  
TEL +613-95-852739  
36 Taunton Drive, Cheltenham, Victoria 3192  
AUSTRALIA.  
sales@apexdyna.com.au  
www.apexdyna.com.au



**APEX DYNAMICS (I) JV**  
TEL +91-80-55345541  
GAT No. 279, KHED SHIVAPUR BAUG, TALUKA  
HAVELI PUNE- 412205 INDIA.  
sales@apexdyna.co.in  
www.apexdyna.co.in



**APEX DYNAMICS FRANCE SAS**  
TEL +33-160-135097  
11 - Burospace F - 91570 -  
Bièvres, FRANCE  
info@apexdyna.fr  
www.apexdyna.fr



**APEX DYNAMICS SWEDEN AB**  
TEL +46-75-242444  
Fredrikbergsgatan 2 SE-573 92 Tranås, SWEDEN  
sales@apexdyna.se  
www.apexdyna.se



**PT.APEX DYNAMICS INDONESIA**  
TEL +62 21 2928 3681  
Rukan Aralia Blok HY43 no.11, Harapan Indah II,  
Bekasi - Jawa Barat, INDONESIA 17214  
sales@apexdyna.co.id  
www.apexdyna.co.id



**APEX DYNAMICS GERMANY GMBH**  
TEL +49-7181-932955  
Spanninger Str. 9, 73650 Winterbach, GERMANY  
Langer@apexdynamics.de  
www.apexdynamics.de



**APEX DYNAMICS CZECH S.R.O.**  
TEL +420-577-663877  
tř. Tomáše Bati 1851 765 02 Otrokovice ČESKÁ  
REPUBLIKA  
info@apexdynaczech.cz  
www.apexdynaczech.cz



**APEX DYNAMICS РОССИЯ**  
TEL +7-495-2255452  
+7-495-6462422  
г. Москва, ул. Южнопортовая, дом 7, строение  
"С", 3-й этаж  
info@apexdynarussia.ru  
www.apexdynarussia.ru



**APEX DYNAMICS UK LIMITED**  
TEL +44-1827-253340  
2 Centurion Way, Centurion Park, Tamworth  
Staffs, B77 5PN, UK  
sales@apexdynamicsuk.com  
www.apexdynamicsuk.com



**APEX DYNAMICS SWITZERLAND AG**  
TEL +41-55-4517020 Talstrasse 24, CH-8852  
Altendorf, SWITZERLAND  
info@apexdyna.ch  
www.apexdyna.ch



**APEX DYNAMICS MOTION SDN BHD**  
TEL +60 7237 1055  
No. 1, Jalan Perniagaan Setia 3, Taman  
Perniagaan Setia, 81100 Johor Bahru, Johor,  
MALAYSIA (Setia Business Park 2 @ Iskandar  
Malaysia)  
sales@apexdyna.com.sg  
www.apexdyna.com.sg



**APEX DYNAMICS BRAZIL**  
TEL +55-47-30298700  
Rua Senador Petrônio Portela, 47 - Bloco 5, Zona  
Industrial Norte - CEP 89218-575 - Joinville (SC)  
lucan@neoyama.com.br  
adriano.duarte@neoyama.com.br  
www.neoyama.com.br



**APEX DYNAMICS ITALY**  
TEL +39 02.36634521  
VIA E. DE AMICIS, 2 – 20091 BRESSO (MI)  
info@apexdynamics.it  
www.apexdynamics.it



## APEX DYNAMICS, INC.

No. 10, Keyuan 3<sup>rd</sup> Rd., Situn District, Taichung City 40763, Taiwan (R.O.C.)  
Tel:886-4-24650219 | Fax:886-4-24650118  
sales@apexdyna.com | http://www.apexdyna.com

APEX-2018-07-AB/ABR Series - 1.0V

Printed in Taiwan

