

alpha Premium Line Product catalog

Unique
Individual
Highly efficient





alpha

alpha Premium Line Product catalog

Unique
Individual
Highly efficient

© 2020 by WITTENSTEIN alpha GmbH

All technical specifications were correct at the time of going to print. We are continually developing our products and therefore reserve the right to make modifications. This documentation is subject to occasional errors. Please appreciate that legal claims cannot be asserted as a result of incorrect specifications, illustrations or descriptions. The text, photos, technical drawings and any other illustrations printed in this publication are protected property of WITTENSTEIN alpha GmbH.

Further use of this material in printed or electronic format requires express approval from WITTENSTEIN alpha GmbH.

Any form of duplication, translation, editing, transfer to microfilm or storage on electronic systems is not permitted without express permission from WITTENSTEIN alpha GmbH.

Contents

Foreword by company management 06

WITTENSTEIN alpha 08

More than 35 years of innovation

Engineering tools 12

alpha Premium Line 16

Product range and applications

Planetary gearboxes 22

XP⁺ 24

RP⁺ 36

Hypoid gearboxes 52

XPK⁺/RPK⁺ 54

Bevel gearboxes 64

XPC⁺/RPC⁺ 66

Product portfolio & company 76

Gearbox overview	76	Accessories	90
alpha Linear Systems	84	Services	92
premo [®] servo actuators	86	WITTENSTEIN Group	98
Galaxie [®] drive systems	88		

Information 100

Design strategy	100
Glossary	102
Order codes	108



Dear Business Associates,

Even though we are extremely passionate about technology and innovation, the success of our customers is our top priority. We have designed our products and services to help you achieve a competitive advantage – through consistently high quality, permanent availability and the best service worldwide.

The product portfolio is divided into four product segments, which have already been successfully established on the market. The alpha Premium Line offers unique, individual solutions. Our alpha Advanced Line provides maximum power density, compact precision and outstanding positioning accuracy. Gearboxes of the alpha Basic and alpha Value Line are especially suitable for applications requiring cost-oriented, particularly flexible yet efficient solutions.

You are sure to find the right solution quickly and easily from our product range. We offer holistic mechanical and mechatronic drive solutions for all types of axis. We also provide complete solutions from a single source on request. Our range of products and solutions will continue to grow in the future because we never stop developing new ideas to make your work easier.

Take our word for it!

Thomas Patzak and Norbert Pastoors
Managing Directors WITTENSTEIN alpha GmbH



YOUR WORLD IS OUR DRIVE.

FOR MORE THAN 35 YEARS.



SP



LP



Linear systems



TPM+

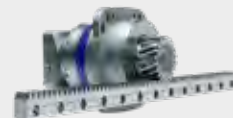

High Performance Linear System



alpha Value Line

1983

1994

1996

1999

2002

2004

2006

2007

2011

2013

2015

TP



cymex®
sizing software



XP+ / TP+ / SP+ / LP+



TPK+ / SPK+ /
HG+ / SK+ / TK+



HDV
Hygienic Design



PERFORMANCE

Performance where it counts:
High torque, outstanding precision and high power density – essential for our products and systems.

FUTURE PROOF

We live processes:
Only those who know the exact details of customer processes and requirements are in a position to develop solutions that offer added value in the short and long term.

SCALABILITY

You never make compromises:
Whatever the performance area – we offer solutions that grow with your requirements.



WITTENSTEIN

alpha

It is good to know today what will be needed tomorrow. Applying it in practice is even better. We develop technology that shapes the future – ENGINEERING FUTURE SOLUTIONS.

EFFICIENCY

We like it „lean“:
We offer products and systems that are energy-efficient and require minimal installation space in machines.

AVAILABILITY

You need reliability:
We have the widest range of products on the market and can implement your application „just in time“.

CONNECTIVITY

We think in terms of interfaces:
All of our systems can be integrated in a wide range of peripherals.



DP+ for Delta robots



INIRA®



alpha Linear Systems



alpha Basic Line



cynapse

2016

cymex® 5



2017

SIZING ASSISTANT



V-Drive Family



2018

premo®



2019

CAD POINT



WITTENSTEIN Service Portal



WITTENSTEIN alpha on all axes

Complete drive solutions under one roof

We offer the best solutions for almost every application. In addition to gearboxes, our product portfolio includes a wide range of drive solutions with linear systems and servo actuators. Adapted accessories such as couplings and shrink disks round off the product portfolio.

The diagrams below provide a quick overview of our product portfolio for a wide variety of requirements and applications:

Planetary gearboxes

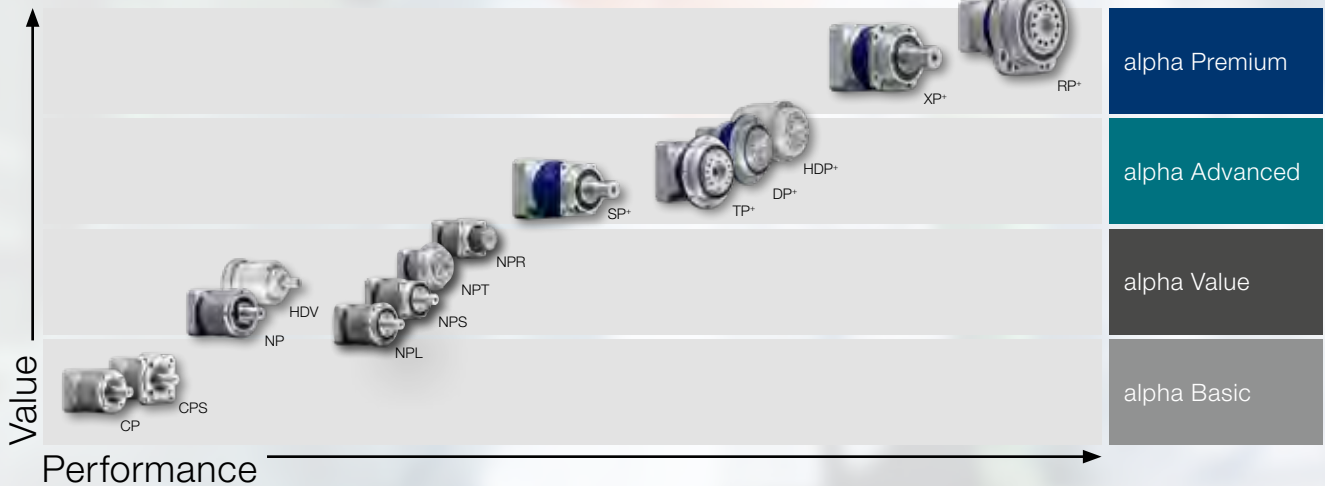

Hypoid, bevel and worm gearboxes

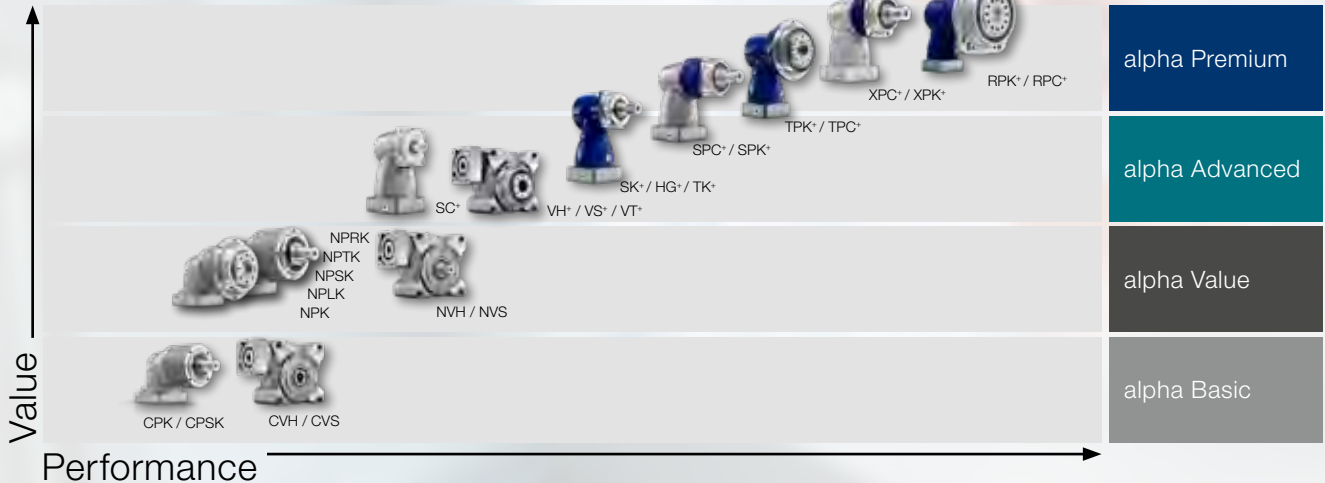

Know-how in every sector

Our solutions range from high-precision axes in manufacturing systems to packaging machines that must operate with maximum productivity in the smallest installation space. Overview:

- Machine tools and production technology
- Food and packaging machines
- Wood working machinery
- Printing and paper machines
- Robotics and automation

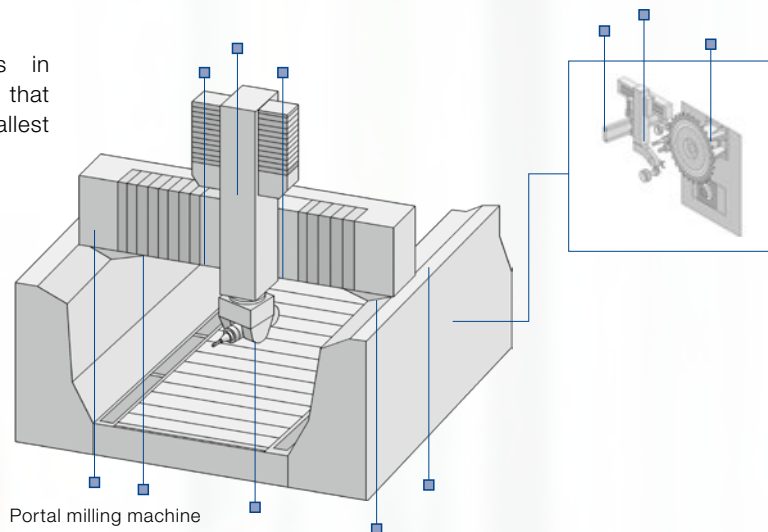

Linear systems

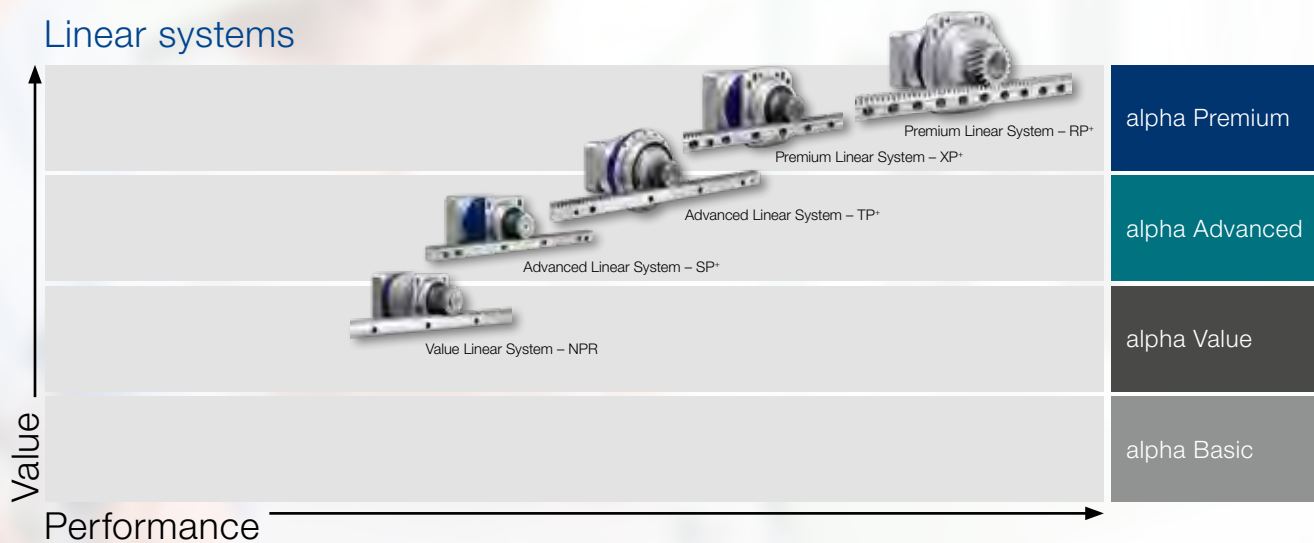

Servo actuators

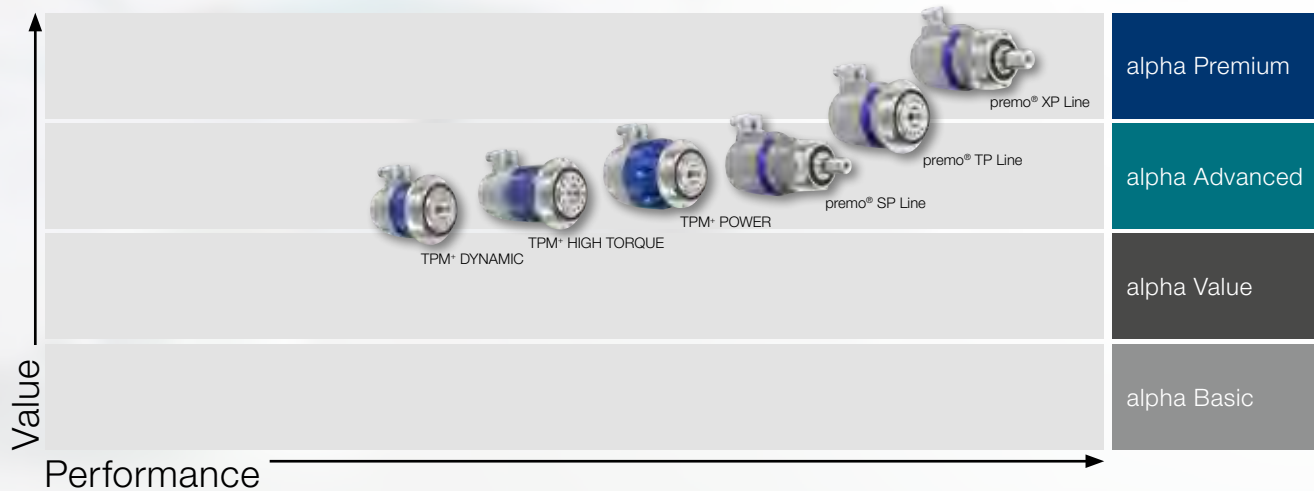

WITTENSTEIN alpha Tools – several ways to reach your objectives

Our software portfolio helps you choose the right drive

You can conveniently download dimension sheets and CAD data, select the best gearbox quickly and easily design complex kinematic sequences in detail – our software solutions offer various methods of selecting the best, most reliable drive on all axes.



CAD POINT – Your Smart Catalog

- Performance data, dimension sheets and CAD data for all types of gearbox
- Comprehensive documentation of the selection
- Available online without logging in

www.wittenstein-cad-point.com

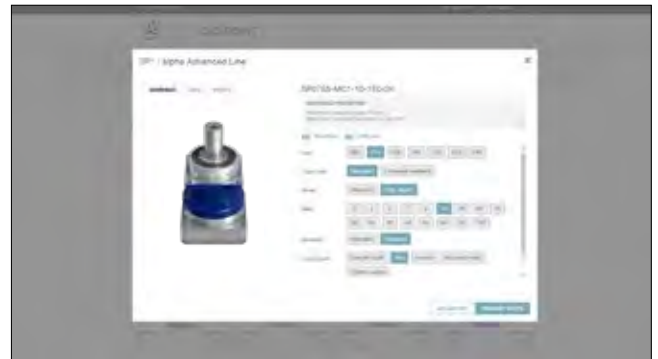

SIZING ASSISTANT – Your Gearbox within Seconds

- Efficient gearbox selection in seconds
- Access by specifying application or motor
- Information about price and delivery time
- Possibility of requesting quotation directly
- Available online without logging in

www.sizing-assistant.com

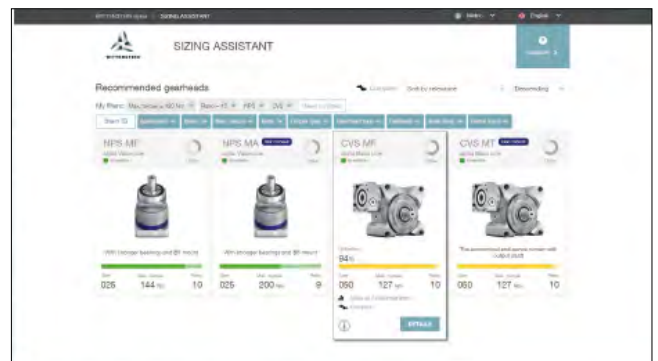

cymex®5 – Calculate on the Best

- Detailed calculation of complete drive trains
- Precise simulation of motion and load variables
- Downloadable software for complex designs

www.wittenstein-cymex.com





cymex[®]5 is the current standard

With cymex[®] 5, the dimensioning and design of complete drive trains (application + transformation + gearbox + motor) is now fast, simple and reliable. Calculation is made much easier through predefined standard applications. Consideration for all major influencing factors guarantees an optimal design and increases the efficiency of your machine.

cymex[®] 5 can define any number of axes simultaneously

In contrast to other design tools, cymex[®]5 can define any number of axes at the same time. The version calculation is up to 60% quicker as a result.



cymex[®] 5 has an extremely extensive database

More than 14,000 motors from the 50 most prominent motor manufacturers are stored in the design tool. Continuously updated, always state-of-the-art. Moreover, more than 8,000 gearbox versions from WITTENSTEIN alpha and over 200 combinations of linear systems with all relevant technical specifications can be found here.

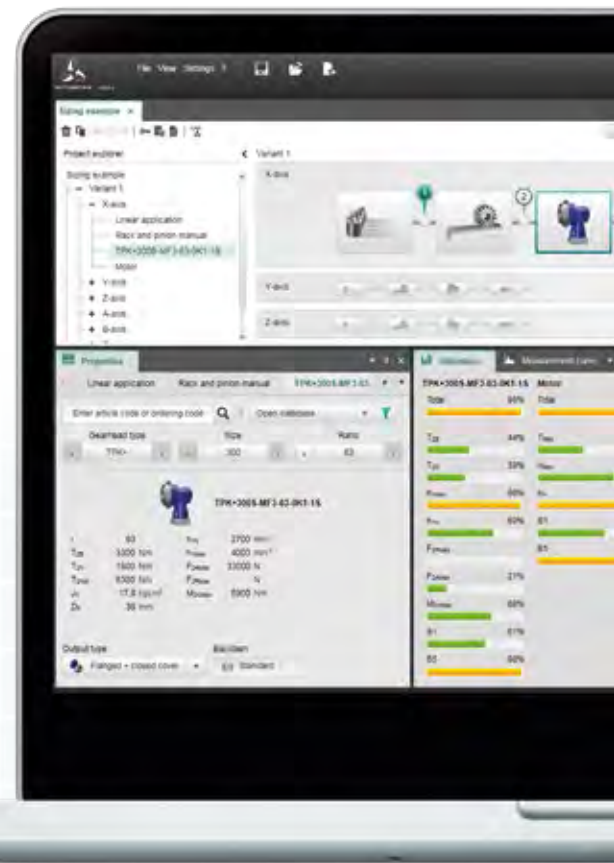

Free download

The basic version of cymex[®]5 design software is available as a free download.



www.wittenstein-cymex.com

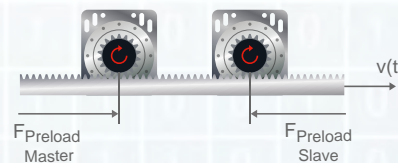

cymex[®] 5 incorporates the completely new Master / Slave function*

The Master / Slave function enables the electrically clamped configuration of two drives. The mutual tensioning of master and slave eliminates the backlash in the drive train and provides for a high degree of rigidity in the machine.

*Premium function, on request.

cymex®5



👍 cymex® 5 has a unique optimization calculator*

During the design process, cymex® 5 provides optimization suggestions for the selected gearbox, which increase reliability and efficiency while ensuring your gearbox has the perfect dimensions e.g. through downsizing. This saves on costs and reduces the installation space in the machine.



👍 cymex® 5 offers comprehensive documentation

Following the geometry comparison, cymex®5 creates calculation documentation and generates data sheets for gearbox and motor on request. Furthermore, the 2D and 3D CAD data of selected components can be retrieved.

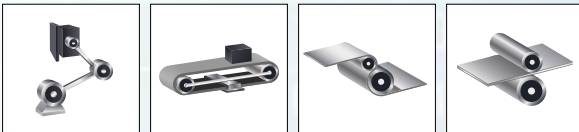

👍 cymex® 5 enables the precise simulation of motion and load variables

The optimized software offers many options for the individual design of the drive train. These have been integrated to supplement the existing applications already in cymex®3: the crank, conveyor, center winder and feed roll.



11 languages

alpha Premium Line – unique, individual solutions that offer unparalleled power density

The requirements for highly complex applications used in machine tools or laser technology, for example, are becoming increasingly demanding and standard products are often unable to meet them. The alpha Premium Line is a completely new product program developed to meet the most demanding requirements. In addition to the products, we primarily focus on offering comprehensive consultancy services to ensure that your requirements are taken into full consideration and maximum machine utilization is achieved. We aim to provide unique "Best in Class" solutions that significantly exceed current standards and help you design your plants more efficiently.

Maximum power density

We increased the performance of our gearboxes by up to 200 % compared to other commercially available standard gearboxes. Our Premium products therefore make a direct contribution to enhancing the performance of your plant.

Maximum positioning accuracy

On request, the Premium planetary gearboxes are available with torsional backlash of less than one arc minute. In combination with maximum torsional rigidity, this backlash guarantees outstanding positioning accuracy.

Easy installation

Specially designed output configurations allow for quick and easy installation.

Top engineering and expert consultation

We use our extensive engineering expertise to develop unique solutions and produce the perfect design for your drive train. Our highly qualified employees provide support and advice from the initial idea and throughout the entire life cycle of your application.

alpha Premium solutions.
Tailored precisely to meet your needs.

More performance in less space

- if you require an even more compact drive
- if you wish to enhance the performance of your machine
- if you require high-performance linear systems



A photograph of a man in a dark blue suit, light blue shirt, and blue tie, smiling warmly. He is looking towards a customer whose back is to the camera. The customer is wearing a white shirt and glasses. They are in a bright office setting with a window in the background showing greenery.

"We develop pioneering solutions for demanding applications in close dialog with our customers."

Sven Sanitz, Sales

Reaching new heights: the alpha Premium Line

Planetary gearboxes

The unique capabilities of planetary gearboxes from the alpha Premium Line are setting new standards on the market. These compact gearboxes are characterized by a power density far above the current industry standard. Your application can benefit directly from this increase in performance.



Hypoid gearboxes

Maximum power density and high modularity are just two of the special characteristics of our hypoid gearboxes. Furthermore, gearboxes from the alpha Premium Line are characterized by an extremely robust overall design that guarantees a high degree of reliability and a long service life.



Premium Line

Bevel gearboxes

The low backlash bevel drives from our alpha Premium Line offer outstanding performance at low ratios during both cyclic and continuous operation. The perfect solution for dynamic applications with demanding requirements with regard to precision, torque and output speed. Increases in the performance of your plant can easily be achieved with a 97 % degree of efficiency.





alpha Premium Line in action

RPK+ – when high performance is required in a small installation space

Whether laser cutting machines, turning and milling machines, or pipe bending machines – the use of powerful gearboxes with a high degree of positioning accuracy is essential in rack and pinion applications. The compact RPK+ combines these characteristics to achieve high feed forces and accurate positioning in the application.



Premium Line products can also be used in machines that generate rotary movements under extreme loads such as flatbed lasers or portal milling machines.

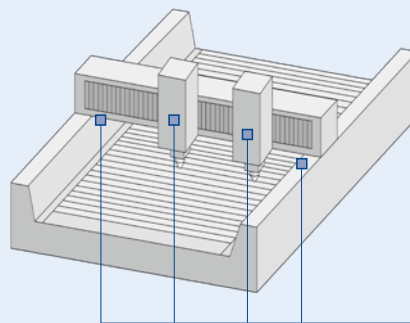

Flatbed laser

Working position

Working position

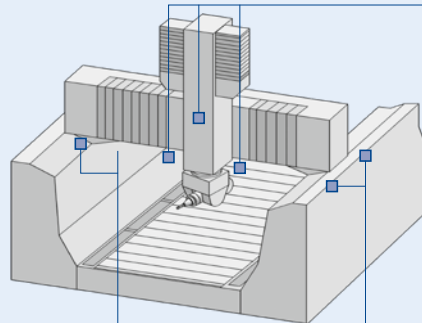

Portal milling machine

Working position



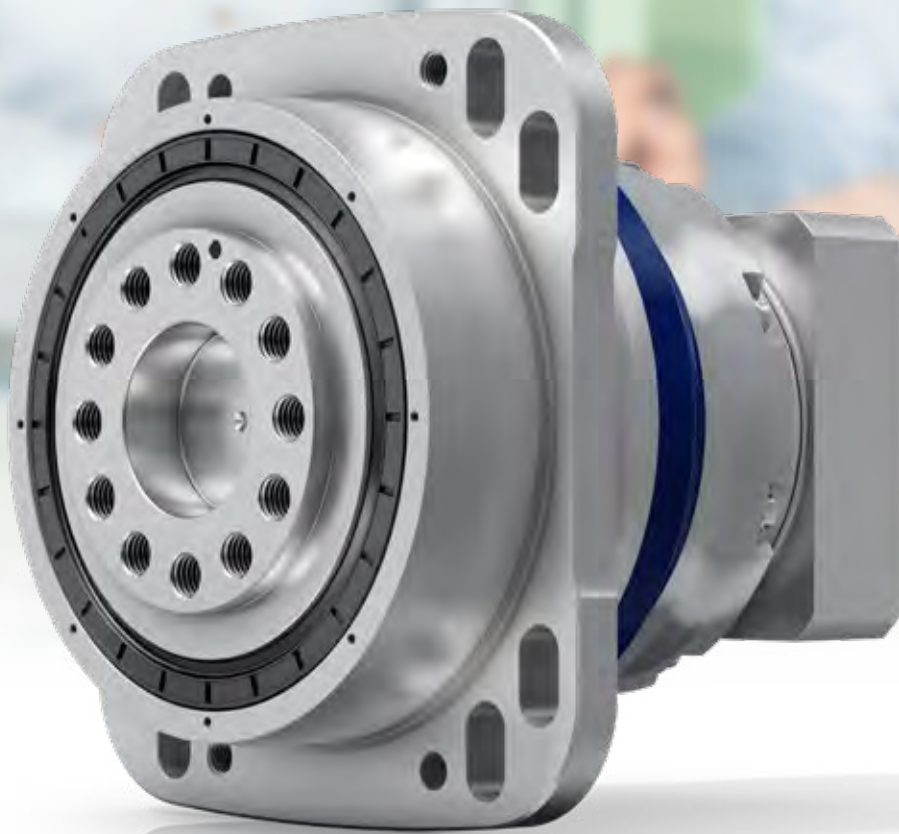

XP⁺ and RP⁺ planetary gearboxes

Unique in performance

XP+ – Perfection in a new dimension



XP+

The XP+ with specially designed output and extremely compact design offers new dimensions in power transmission that far exceed industry standards. The optimized interfaces on the output can generate much higher torques that directly benefit your application.

The XP+ impresses with maximum power density

- if you require an even more compact drive
- if you wish to enhance the performance of your machine
- if you require high-performance linear systems

The XP+ compared to the industry standard

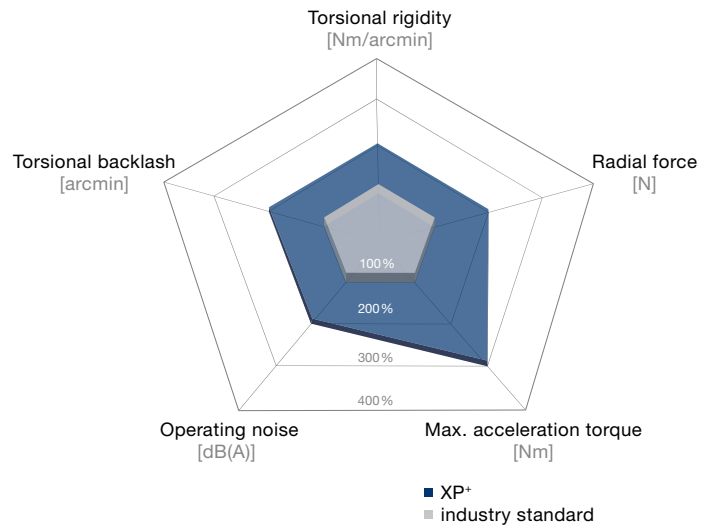

Product highlights

Max. torsional backlash [arcmin] $\leq 1 - 4$

Maximum power density

High axial and radial forces



XP+ with splined shaft



XP+ with pinion and slots

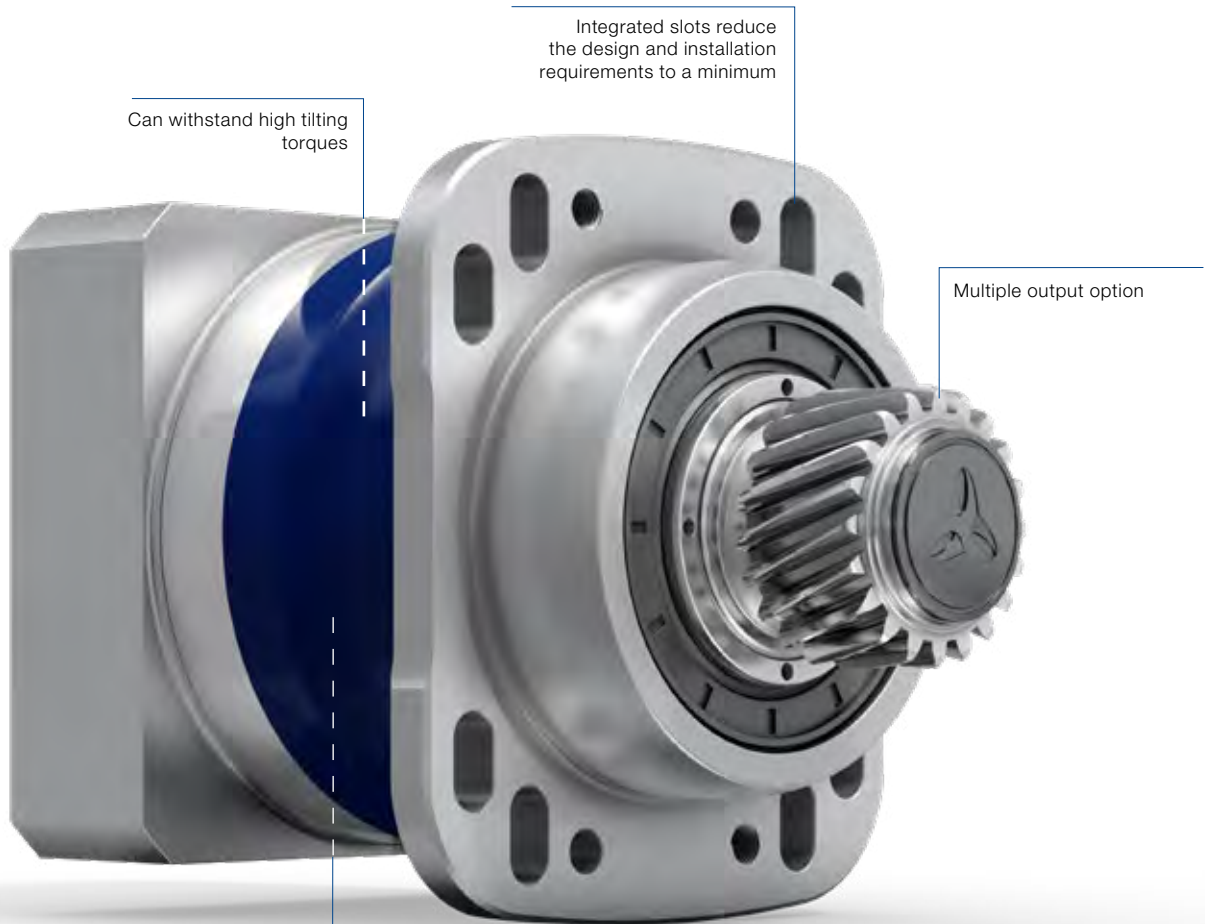

Can withstand high tilting torques

Integrated slots reduce the design and installation requirements to a minimum

Multiple output option

XP⁺ with pinion and slots

Outstanding tothing quality minimizes torsional backlash

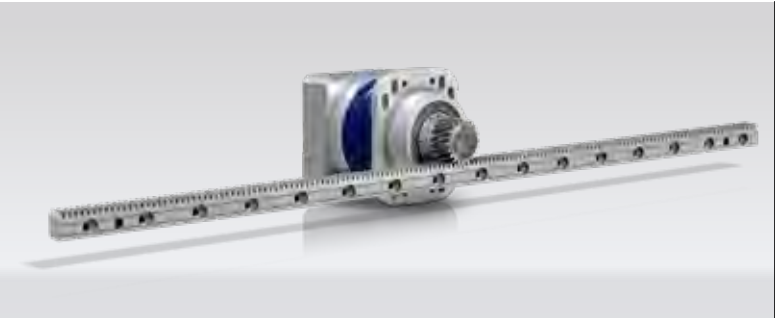

XP⁺ with pinion, slots and rack



premo[®] XP Line with pinion

XP+ 010 MF 1-/2-stage

			1-stage	2-stage
Ratio	i		3 / 4 / 5 / 7 / 8 / 10	16 / 20 / 25 / 28 / 32 / 35 / 40 / 50 / 64 / 70 / 100
Max. torque ^{a)}	T_{2a}	Nm	56 – 128	50 – 119
		$in.lb$	496 – 1133	446 – 1051
Max. acceleration torque (max. 1000 cycles per hour)	T_{2B}	Nm	42 – 108	42 – 99
		$in.lb$	372 – 956	372 – 876
Nominal torque (at n_n)	T_{2N}	Nm	21 – 27	34 – 53
		$in.lb$	190 – 239	297 – 467
Emergency stop torque (permitted 1000 times during the service life of the gearbox)	T_{2Not}	Nm	110 – 165	110 – 165
		$in.lb$	974 – 1458	974 – 1458
Thermal speed limit (with 20°C ambient temperature and 10% torque utilization) ^{b)}	n_{IT}	rpm	3300 – 4000	4400 – 5500
Max. input speed	n_{IMax}	rpm	7500	8500
Max. torsional backlash	j_t	$arcmin$	Standard ≤ 4 / Reduced ≤ 2	Standard ≤ 5 / Reduced ≤ 3
Torsional rigidity	C_{t21}	$Nm/arcmin$	5 – 6.5	5 – 6.5
		$in.lb/arcmin$	44 – 58	44 – 58
Max. tilting moment	M_{2KMax}	Nm	339	339
		$in.lb$	3000	3000
Operating noise ^{c)}	L_{PA}	$dB(A)$	≤ 55	≤ 53
Lubrication			Lubricated for life	Lubricated for life
Clamping hub diameter		mm	11 – 19	11 – 14

^{a)} Application-specific design with cymex® – www.wittenstein-cymex.com

^{b)} For higher ambient temperatures, please reduce input speed

^{c)} At reference ratio and reference speed. Ratio-specific values available in cymex®.

1-stage

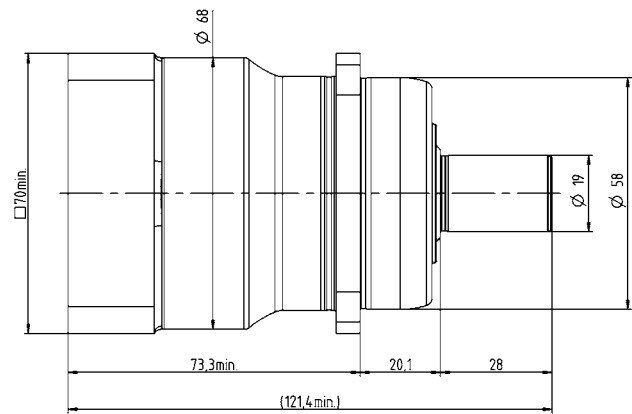
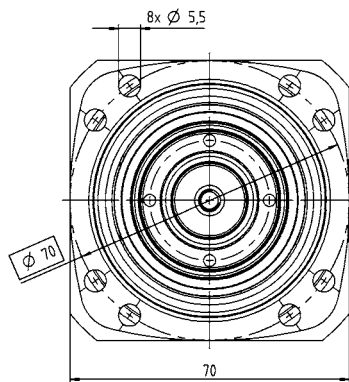

2-stage

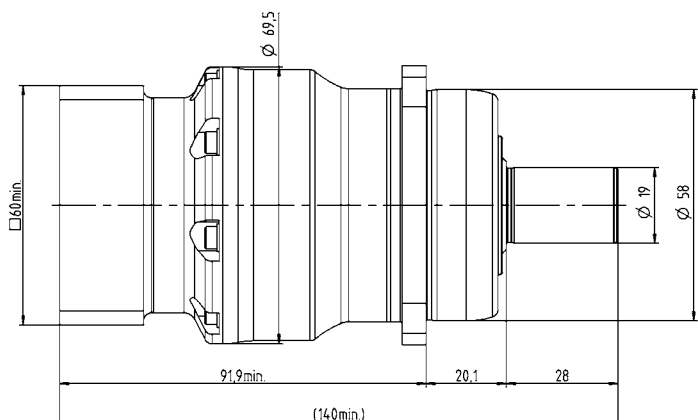
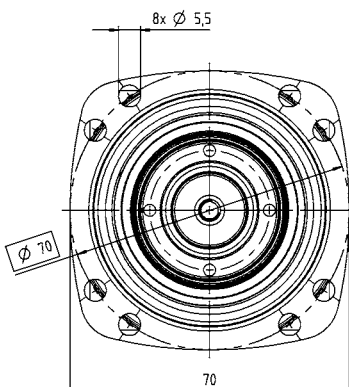

			1-stage	2-stage
Ratio	i		3 / 4 / 5 / 7 / 8 / 10	16 / 20 / 25 / 28 / 32 / 35 / 40 / 50 / 64 / 70 / 100
Max. torque ^{a)}	T_{2a}	<i>Nm</i>	168 – 330	139 – 348
		<i>in.lb</i>	1487 – 2921	1227 – 3080
Max. acceleration torque (max. 1000 cycles per hour)	T_{2B}	<i>Nm</i>	126 – 275	126 – 303
		<i>in.lb</i>	1115 – 2434	1115 – 2682
Nominal torque (at n_{2N})	T_{2N}	<i>Nm</i>	63 – 81	101 – 145
		<i>in.lb</i>	558 – 720	101 – 145
Emergency stop torque (permitted 1000 times during the service life of the gearbox)	T_{2Not}	<i>Nm</i>	325 – 390	325 – 418
		<i>in.lb</i>	2877 – 3452	2877 – 3696
Thermal speed limit (with 20°C ambient temperature and 10% torque utilization) ^{b)}	n_{1T}	<i>rpm</i>	2900 – 3100	3500 – 4500
Max. input speed	n_{1Max}	<i>rpm</i>	7500	8500
Max. torsional backlash	j_t	<i>arcmin</i>	Standard ≤ 3 / Reduced ≤ 1	Standard ≤ 4 / Reduced ≤ 2
Torsional rigidity	C_{t21}	<i>Nm/arcmin</i>	14 – 17	15 – 20
		<i>in.lb/arcmin</i>	124 – 150	133 – 173
Max. tilting moment	M_{2KMax}	<i>Nm</i>	675	675
		<i>in.lb</i>	5974	5974
Operating noise ^{c)}	L_{PA}	<i>dB(A)</i>	≤ 56	≤ 53
Lubrication			Lubricated for life	Lubricated for life
Clamping hub diameter		<i>mm</i>	14 – 24	11 – 19

^{a)} Application-specific design with cymex® – www.wittenstein-cymex.com

^{b)} For higher ambient temperatures, please reduce input speed

^{c)} At reference ratio and reference speed. Ratio-specific values available in cymex®.

1-stage

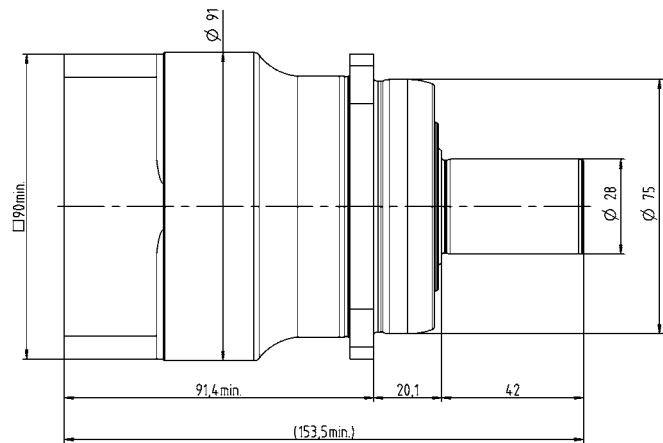
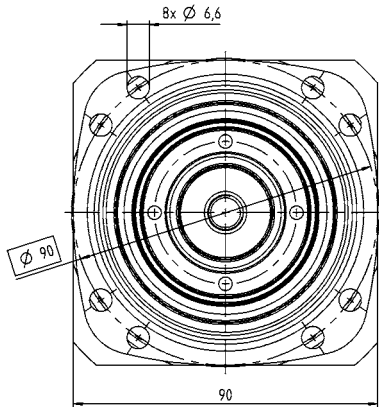

2-stage

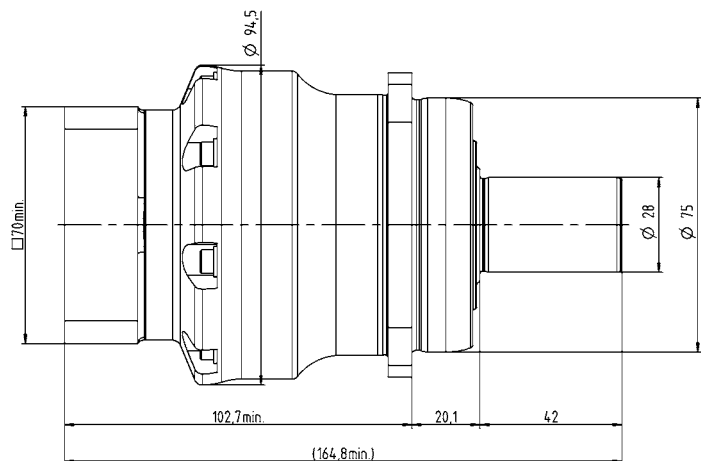
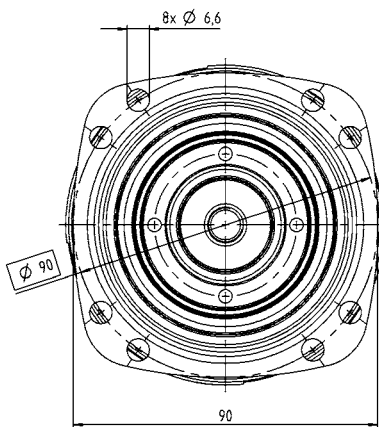

XP+ 030 MF 1-/2-stage

			1-stage	2-stage
Ratio	i		3 / 4 / 5 / 7 / 8 / 10	16 / 20 / 25 / 28 / 32 / 35 / 40 / 50 / 64 / 70 / 100
Max. torque ^{a)}	T_{2a}	Nm	388 – 600	363 – 660
		in.lb	3434 – 5310	3213 – 5842
Max. acceleration torque (max. 1000 cycles per hour)	T_{2B}	Nm	320 – 550	303 – 550
		in.lb	2832 – 4868	2682 – 4868
Nominal torque (at n_n)	T_{2N}	Nm	131 – 174	242 – 319
		in.lb	1157 – 1538	2142 – 2826
Emergency stop torque (permitted 1000 times during the service life of the gearbox)	T_{2Not}	Nm	650 – 900	750 – 1125
		in.lb	5753 – 7966	6638 – 9957
Thermal speed limit (with 20°C ambient temperature and 10% torque utilization) ^{b)}	n_{1T}	rpm	2500 – 2800	3100 – 4200
Max. input speed	n_{1Max}	rpm	5500	6500
Max. torsional backlash	j_t	arcmin	Standard ≤ 3 / Reduced ≤ 1	Standard ≤ 4 / Reduced ≤ 2
Torsional rigidity	C_{t21}	Nm/arcmin	32 – 40	35 – 45
		in.lb/arcmin	283 – 354	310 – 398
Max. tilting moment	M_{2KMax}	Nm	1296	1296
		in.lb	11471	11471
Operating noise ^{c)}	L_{PA}	dB(A)	≤ 59	≤ 56
Lubrication			Lubricated for life	Lubricated for life
Clamping hub diameter		mm	19 – 38	14 – 28

^{a)} Application-specific design with cymex® – www.wittenstein-cymex.com

^{b)} For higher ambient temperatures, please reduce input speed

^{c)} At reference ratio and reference speed. Ratio-specific values available in cymex®.

1-stage

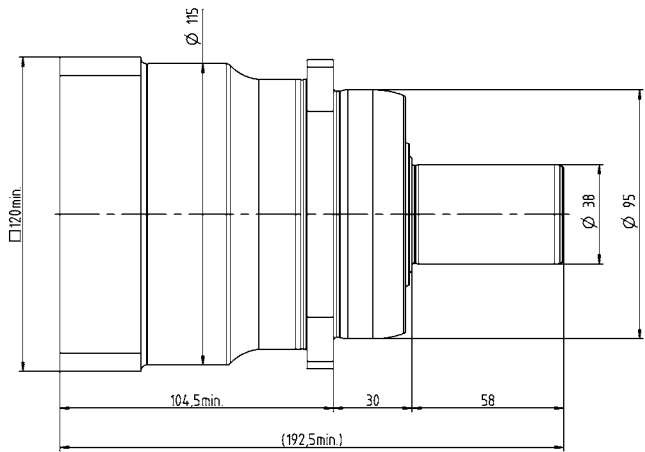
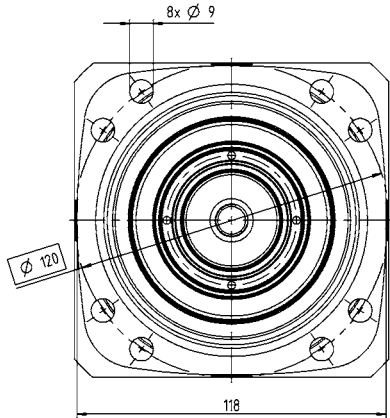

2-stage

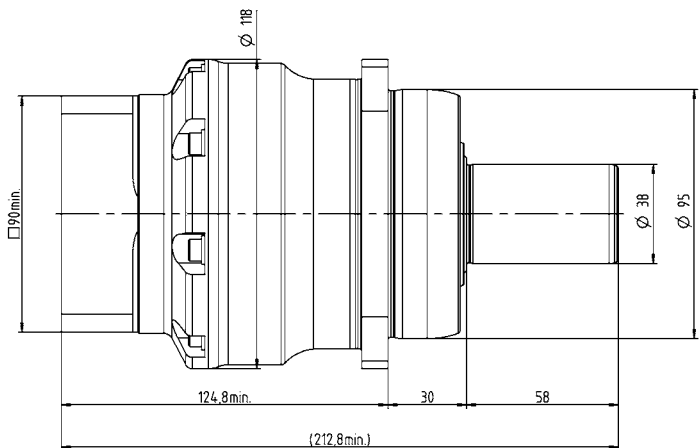
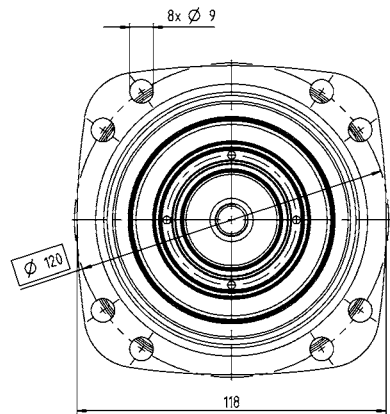

			1-stage	2-stage
Ratio	i		3 / 4 / 5 / 7 / 8 / 10	16 / 20 / 25 / 28 / 32 / 35 / 40 / 50 / 64 / 70 / 100
Max. torque ^{a)}	T_{2a}	Nm	792 – 1312	792 – 1188
		in.lb	7010 – 11612	7010 – 10515
Max. acceleration torque (max. 1000 cycles per hour)	T_{2B}	Nm	710 – 1080	660 – 990
		in.lb	6284 – 9559	5842 – 8762
Nominal torque (at n_n)	T_{2N}	Nm	202 – 335	461 – 607
		in.lb	1786 – 2962	4078 – 5370
Emergency stop torque (permitted 1000 times during the service life of the gearbox)	T_{2Not}	Nm	1375 – 2310	1375 – 2310
		in.lb	12170 – 20449	12170 – 20449
Thermal speed limit (with 20°C ambient temperature and 10% torque utilization) ^{b)}	n_{TT}	rpm	2100 – 2600	2900 – 3900
Max. input speed	n_{1Max}	rpm	5000	6000
Max. torsional backlash	j_t	arcmin	Standard ≤ 3 / Reduced ≤ 1	Standard ≤ 4 / Reduced ≤ 2
Torsional rigidity	C_{t21}	Nm/arcmin	62 – 85	75 – 95
		in.lb/arcmin	549 – 752	664 – 841
Max. tilting moment	M_{2KMax}	Nm	1635	1635
		in.lb	14471	14471
Operating noise ^{c)}	L_{PA}	dB(A)	≤ 60	≤ 57
Lubrication			Lubricated for life	Lubricated for life
Clamping hub diameter		mm	24 – 48	19 – 38

^{a)} Application-specific design with cymex® – www.wittenstein-cymex.com

^{b)} For higher ambient temperatures, please reduce input speed

^{c)} At reference ratio and reference speed. Ratio-specific values available in cymex®.

1-stage

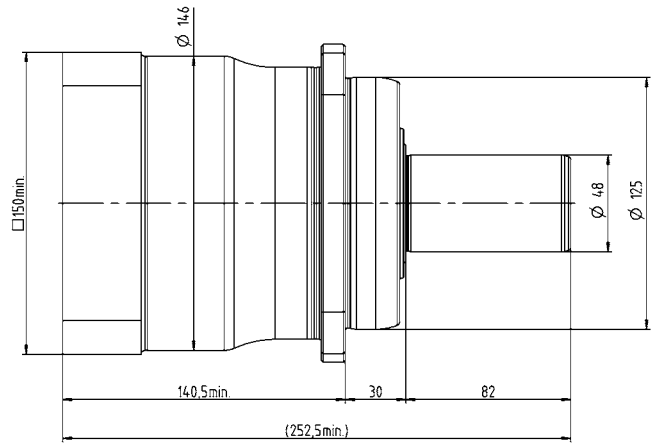
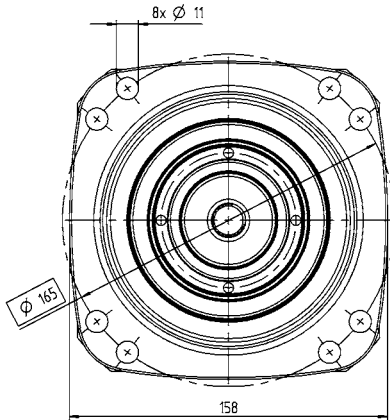

2-stage

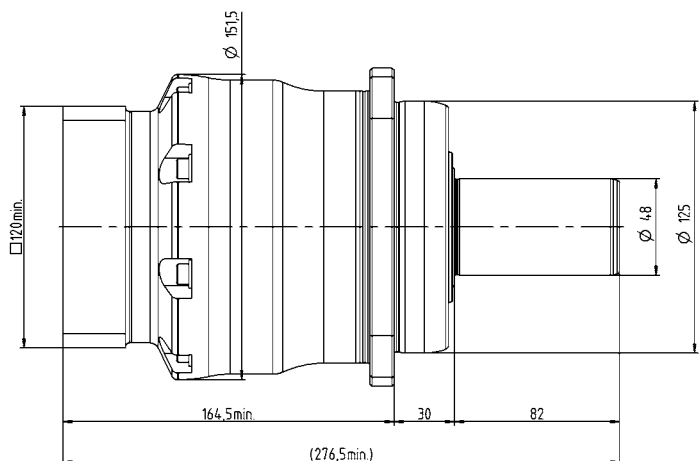
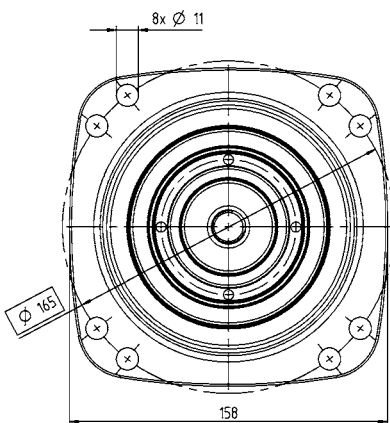

XP+ 050 MF 1-/2-stage

			1-stage	2-stage
Ratio	i		3 / 4 / 5 / 7 / 8 / 10	16 / 20 / 25 / 28 / 32 / 35 / 40 / 50 / 64 / 70 / 100
Max. torque ^{a)}	T_{2a}	<i>Nm</i>	2400 – 3840	1980 – 3696
		<i>in.lb</i>	21242 – 33987	17525 – 32713
Max. acceleration torque (max. 1000 cycles per hour)	T_{2B}	<i>Nm</i>	1800 – 3360	1650 – 3080
		<i>in.lb</i>	15931 – 29739	14604 – 27260
Nominal torque (at n_n)	T_{2N}	<i>Nm</i>	513 – 927	1179 – 1505
		<i>in.lb</i>	4544 – 8203	10426 – 13323
Emergency stop torque (permitted 1000 times during the service life of the gearbox)	T_{2Not}	<i>Nm</i>	3445 – 5000	3505 – 5000
		<i>in.lb</i>	30493 – 44254	31022 – 44254
Thermal speed limit (with 20°C ambient temperature and 10% torque utilization) ^{b)}	n_{IT}	<i>rpm</i>	1500 – 2300	2700 – 3400
Max. input speed	n_{1Max}	<i>rpm</i>	4500	5000
Max. torsional backlash	j_t	<i>arcmin</i>	Standard ≤ 3 / Reduced ≤ 1	Standard ≤ 4 / Reduced ≤ 2
Torsional rigidity	C_{t21}	<i>Nm/arcmin</i>	160 – 250	240 – 290
		<i>in.lb/arcmin</i>	1416 – 2213	2124 – 2567
Max. tilting moment	M_{2KMax}	<i>Nm</i>	3256	3256
		<i>in.lb</i>	28818	28818
Operating noise ^{c)}	L_{PA}	<i>dB(A)</i>	≤ 64	≤ 58
Lubrication			Lubricated for life	Lubricated for life
Clamping hub diameter		<i>mm</i>	38 – 55	24 – 48

^{a)} Application-specific design with cymex® – www.wittenstein-cymex.com

^{b)} For higher ambient temperatures, please reduce input speed

^{c)} At reference ratio and reference speed. Ratio-specific values available in cymex®.

1-stage

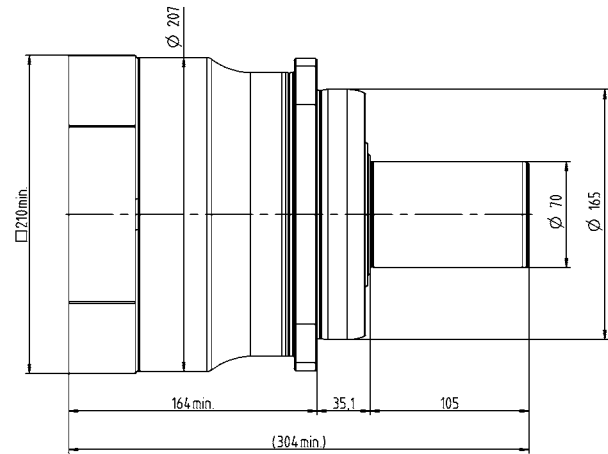
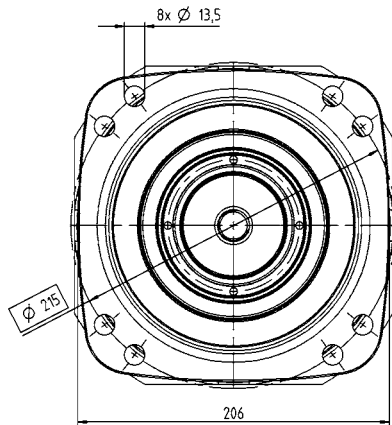

2-stage

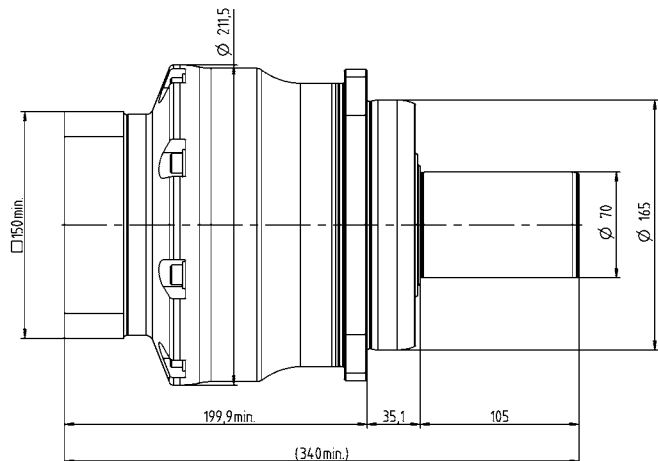
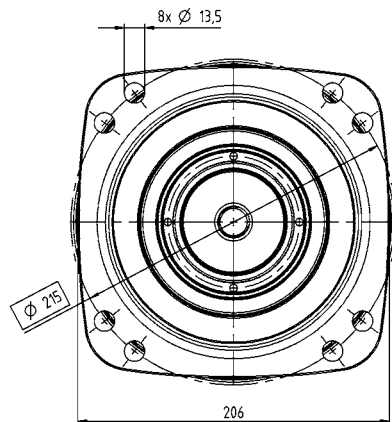

			1-stage	2-stage
Ratio	i		3 / 4 / 5 / 7 / 8 / 10	16 / 20 / 25 / 28 / 32 / 35 / 40 / 50 / 64 / 70 / 100
Max. torque ^{a)}	T_{2a}	Nm	68 – 90	70 – 90
		in.lb	602 – 797	620 – 797
Max. acceleration torque (max. 1000 cycles per hour)	T_{2B}	Nm	68 – 90	70 – 90
		in.lb	602 – 797	620 – 797
Nominal torque (at n_n)	T_{2N}	Nm	41 – 53	56 – 72
		in.lb	362 – 468	496 – 637
Emergency stop torque (permitted 1000 times during the service life of the gearbox)	T_{2Not}	Nm	325 – 390	325 – 418
		in.lb	2877 – 3452	2877 – 3696
Thermal speed limit (with 20°C ambient temperature and 10% torque utilization) ^{b)}	n_{1T}	rpm	4500	4500
Max. input speed	n_{1Max}	rpm	6000	6000
Max. torsional backlash	j_t	arcmin	Standard ≤ 6 / Reduced ≤ 4	Standard ≤ 8 / Reduced ≤ 6
Torsional rigidity	C_{t21}	Nm/arcmin	14 – 17	15 – 20
		in.lb/arcmin	124 – 150	133 – 177
Max. tilting moment	M_{2KMax}	Nm	675	675
		in.lb	5974	5974
Operating noise ^{c)}	L_{PA}	dB(A)	≤ 56	≤ 53
Lubrication			Lubricated for life	Lubricated for life
Clamping hub diameter		mm	19 – 24	14 – 19

^{a)} Application-specific design with cymex® – www.wittenstein-cymex.com
^{b)} For higher ambient temperatures, please reduce input speed
^{c)} At reference ratio and reference speed. Ratio-specific values available in cymex®.

1-stage

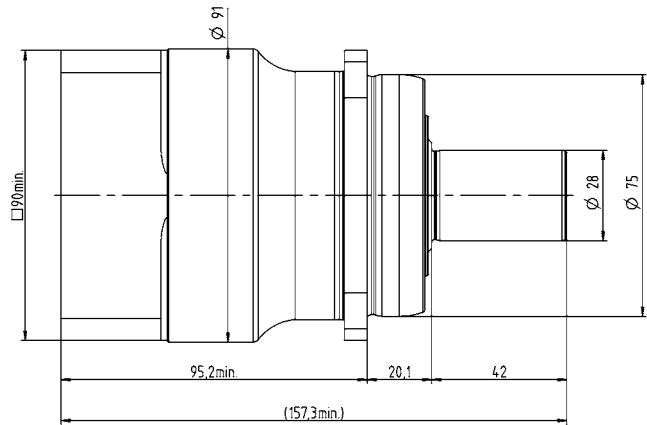
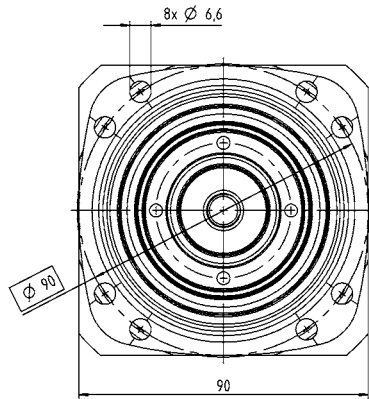

2-stage

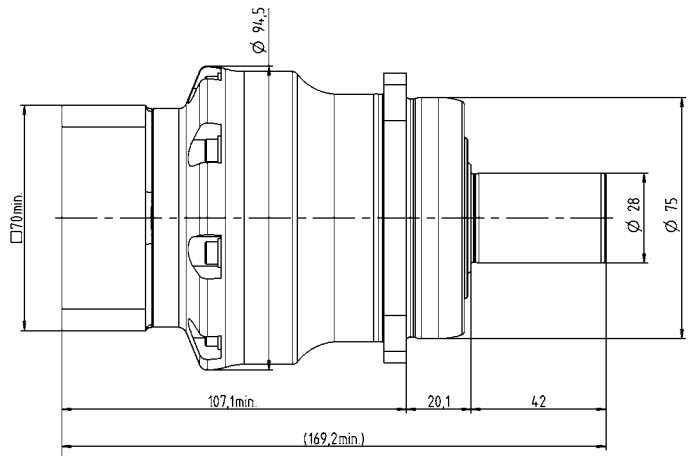
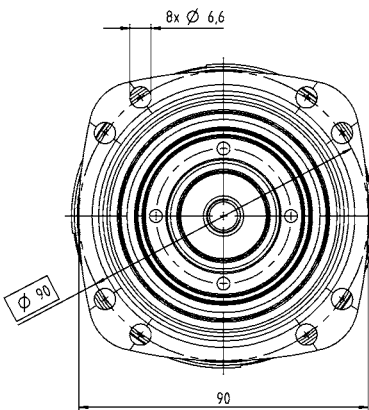

XP+ 030 MC 1-/2-stage

			1-stage	2-stage
Ratio	i		3 / 4 / 5 / 7 / 8 / 10	16 / 20 / 25 / 28 / 32 / 35 / 40 / 50 / 64 / 70 / 100
Max. torque ^{a)}	T_{2a}	<i>Nm</i>	180 – 240	180 – 240
		<i>in.lb</i>	1593 – 2124	1593 – 2124
Max. acceleration torque (max. 1000 cycles per hour)	T_{2B}	<i>Nm</i>	180 – 240	180 – 240
		<i>in.lb</i>	1593 – 2124	1593 – 2124
Nominal torque (at n_n)	T_{2N}	<i>Nm</i>	76 – 97	138 – 189
		<i>in.lb</i>	677 – 861	1221 – 1673
Emergency stop torque (permitted 1000 times during the service life of the gearbox)	T_{2Not}	<i>Nm</i>	650 – 900	750 – 1125
		<i>in.lb</i>	5753 – 7966	6638 – 9957
Thermal speed limit (with 20°C ambient temperature and 10% torque utilization) ^{b)}	n_{1T}	<i>rpm</i>	3500 – 4500	4500
Max. input speed	n_{1Max}	<i>rpm</i>	6000	6000
Max. torsional backlash	j_t	<i>arcmin</i>	Standard ≤ 4 / Reduced ≤ 2	Standard ≤ 6 / Reduced ≤ 4
Torsional rigidity	C_{t21}	<i>Nm/arcmin</i>	32 – 40	35 – 45
		<i>in.lb/arcmin</i>	283 – 354	310 – 398
Max. tilting moment	M_{2KMax}	<i>Nm</i>	1296	1296
		<i>in.lb</i>	11471	11471
Operating noise ^{c)}	L_{PA}	<i>dB(A)</i>	≤ 59	≤ 56
Lubrication			Lubricated for life	Lubricated for life
Clamping hub diameter		<i>mm</i>	24 – 38	19 – 24

^{a)} Application-specific design with cymex® – www.wittenstein-cymex.com

^{b)} For higher ambient temperatures, please reduce input speed

^{c)} At reference ratio and reference speed. Ratio-specific values available in cymex®.

1-stage

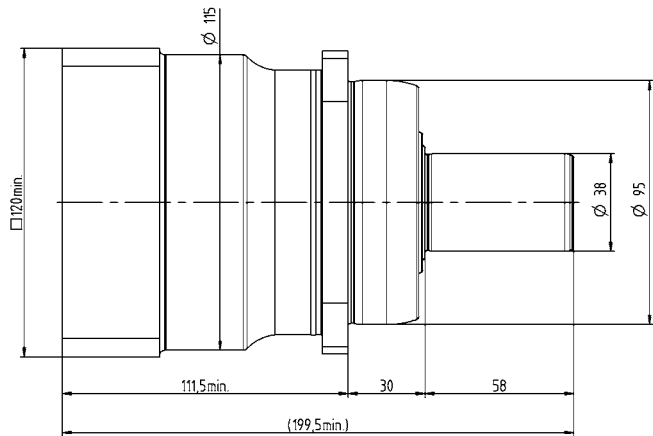
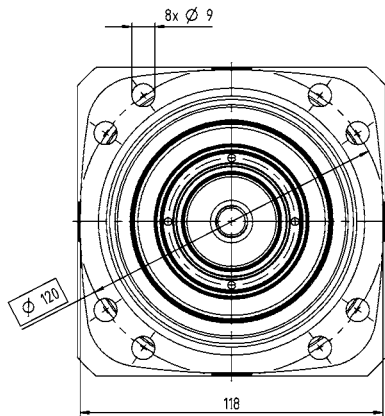

2-stage

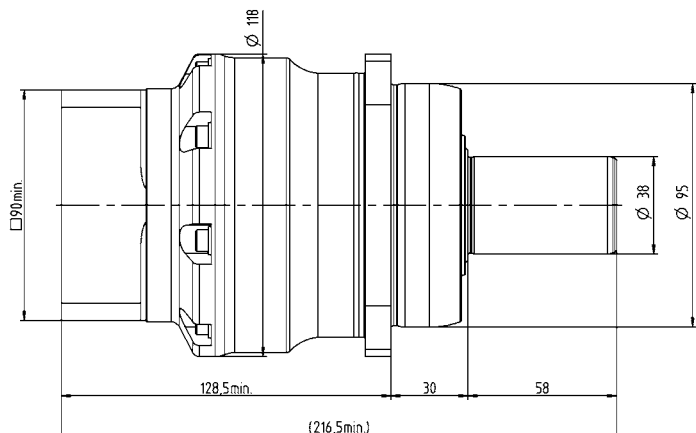
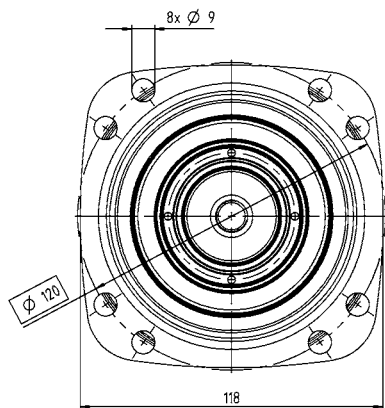

			1-stage	2-stage
Ratio	i		3 / 4 / 5 / 7 / 8 / 10	16 / 20 / 25 / 28 / 32 / 35 / 40 / 50 / 64 / 70 / 100
Max. torque ^{a)}	T_{2a}	Nm	310 – 480	380 – 480
		in.lb	2744 – 4248	3363 – 4248
Max. acceleration torque (max. 1000 cycles per hour)	T_{2B}	Nm	310 – 480	380 – 480
		in.lb	2744 – 4248	3363 – 4248
Nominal torque (at n_{2N})	T_{2N}	Nm	127 – 195	277 – 367
		in.lb	1122 – 1730	2447 – 3250
Emergency stop torque (permitted 1000 times during the service life of the gearbox)	T_{2Not}	Nm	1375 – 2310	1375 – 2310
		in.lb	12170 – 20445	12170 – 20445
Thermal speed limit (with 20°C ambient temperature and 10% torque utilization) ^{b)}	n_{1T}	rpm	3000 – 4500	4500
Max. input speed	n_{1Max}	rpm	6000	6000
Max. torsional backlash	j_t	arcmin	Standard ≤ 4 / Reduced ≤ 2	Standard ≤ 6 / Reduced ≤ 4
Torsional rigidity	C_{t21}	Nm/arcmin	62 – 85	75 – 95
		in.lb/arcmin	549 – 752	664 – 841
Max. tilting moment	M_{2KMax}	Nm	1635	1635
		in.lb	14471	14471
Operating noise ^{c)}	L_{PA}	dB(A)	≤ 60	≤ 57
Lubrication			Lubricated for life	Lubricated for life
Clamping hub diameter		mm	38 – 48	24 – 38

^{a)} Application-specific design with cymex® – www.wittenstein-cymex.com
^{b)} For higher ambient temperatures, please reduce input speed
^{c)} At reference ratio and reference speed. Ratio-specific values available in cymex®.

1-stage

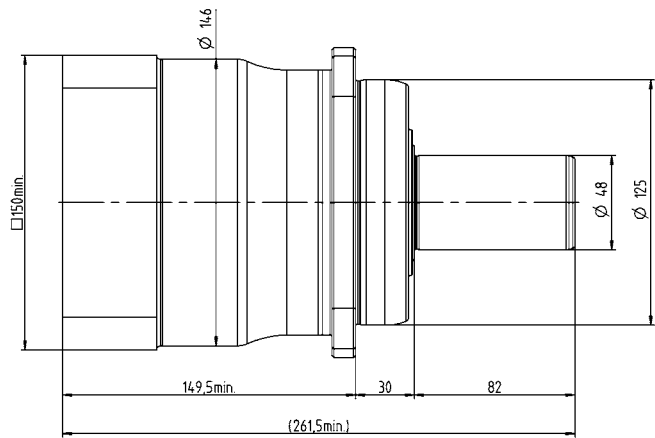
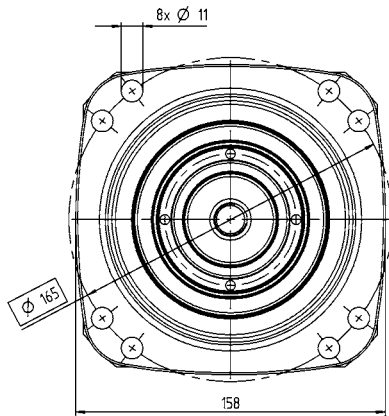

2-stage

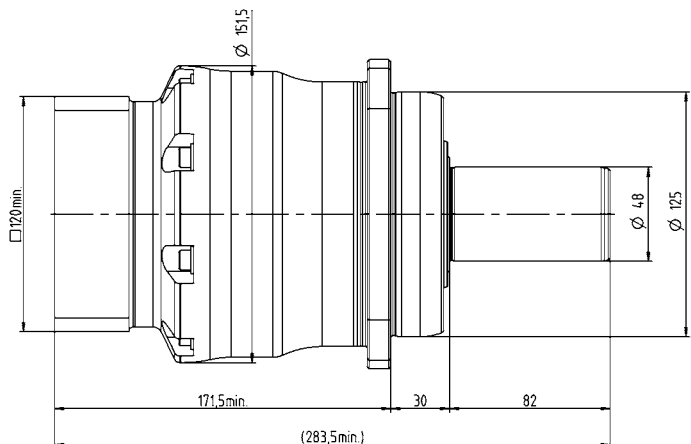
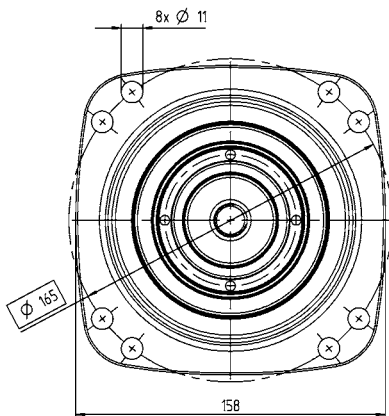

XP+ 050 MC 1-/2-stage

			1-stage	2-stage
Ratio	i		3 / 4 / 5 / 7 / 8 / 10	16 / 20 / 25 / 28 / 32 / 35 / 40 / 50 / 64 / 70 / 100
Max. torque ^{a)}	T_{2a}	Nm	700 – 880	700 – 880
		in.lb	6196 – 7789	6196 – 7789
Max. acceleration torque (max. 1000 cycles per hour)	T_{2B}	Nm	700 – 880	700 – 880
		in.lb	6196 – 7789	6196 – 7789
Nominal torque (at n_n)	T_{2N}	Nm	289 – 492	560 – 704
		in.lb	2554 – 4355	4956 – 6231
Emergency stop torque (permitted 1000 times during the service life of the gearbox)	T_{2Not}	Nm	3445 – 5000	3505 – 5000
		in.lb	30493 – 44254	31022 – 44254
Thermal speed limit (with 20°C ambient temperature and 10% torque utilization) ^{b)}	n_{IT}	rpm	3000 – 4500	4500
Max. input speed	n_{1Max}	rpm	4500 – 6000	6000
Max. torsional backlash	j_t	arcmin	Standard ≤ 4 / Reduced ≤ 2	Standard ≤ 6 / Reduced ≤ 4
Torsional rigidity	C_{t21}	Nm/arcmin	160 – 250	240 – 290
		in.lb/arcmin	1416 – 2213	2124 – 2567
Max. tilting moment	M_{2KMax}	Nm	3256	3256
		in.lb	28818	28818
Operating noise ^{c)}	L_{PA}	dB(A)	≤ 64	≤ 58
Lubrication			Lubricated for life	Lubricated for life
Clamping hub diameter		mm	48	38

^{a)} Application-specific design with cymex® – www.wittenstein-cymex.com

^{b)} For higher ambient temperatures, please reduce input speed

^{c)} At reference ratio and reference speed. Ratio-specific values available in cymex®.

1-stage

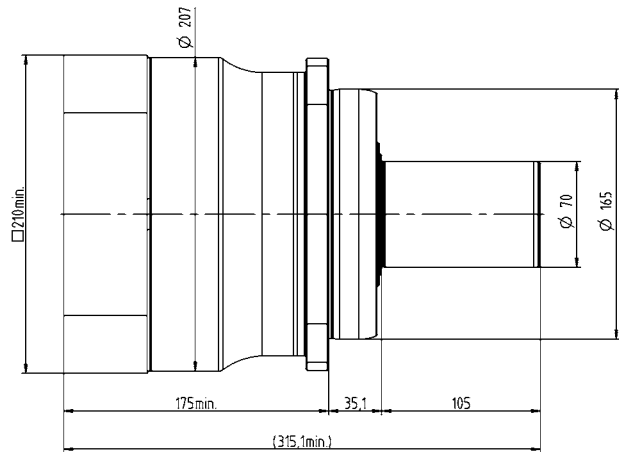
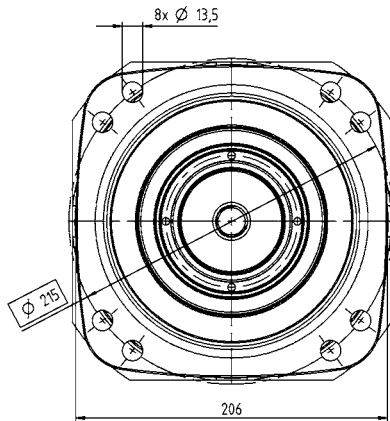

2-stage

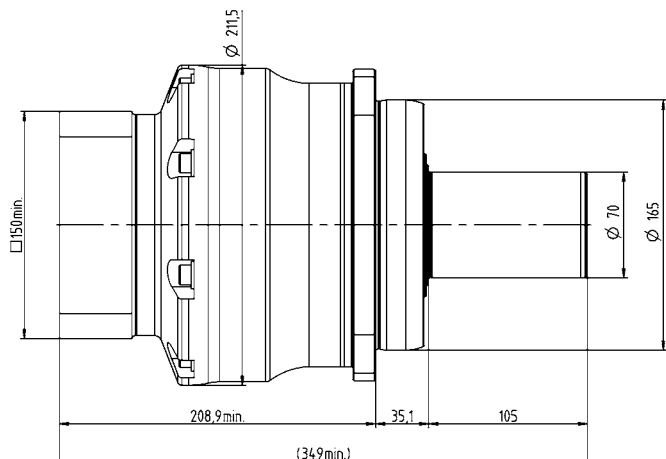
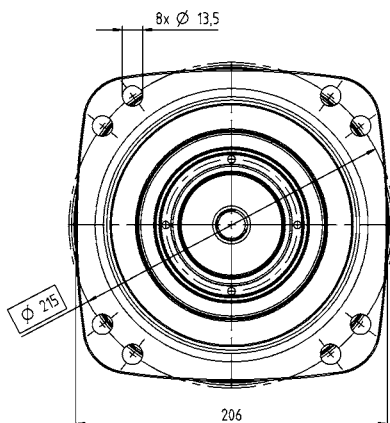



Planetary gearboxes

RP+ – The high-precision powerhouse

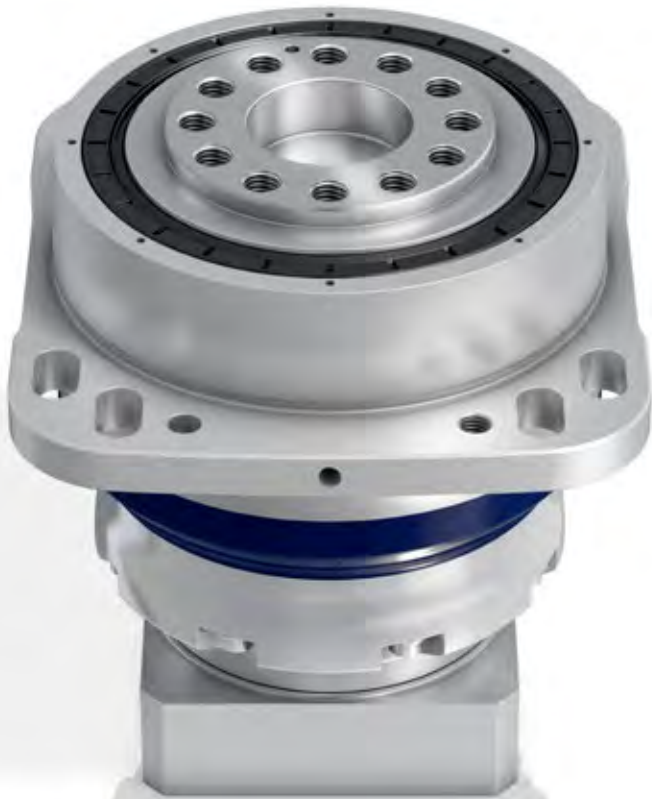

RP+

Product highlights

- Max. torsional backlash [arcmin] $\leq 1 - 3$
- High axial and radial forces
- Easy installation
- Optimized for rack and pinion applications

This gearbox series sets standards in terms of power density, modularity and easy installation. It is used in all applications where the individual requirements far exceed what has previously been possible. RP+ gearboxes combine all the advantages of the familiar gearbox series:

- Reduced backlash of ≤ 1 arcmin
- Maximum power density
- Extremely smooth-running thanks to helical toothing
- Maximum positioning accuracy and world-class lifespan

The RP+ impresses with maximum power density

- if your drive requires maximum performance
- if you value world-class engineering
- if you require an even more compact system

The RP+ compared to the industry standard

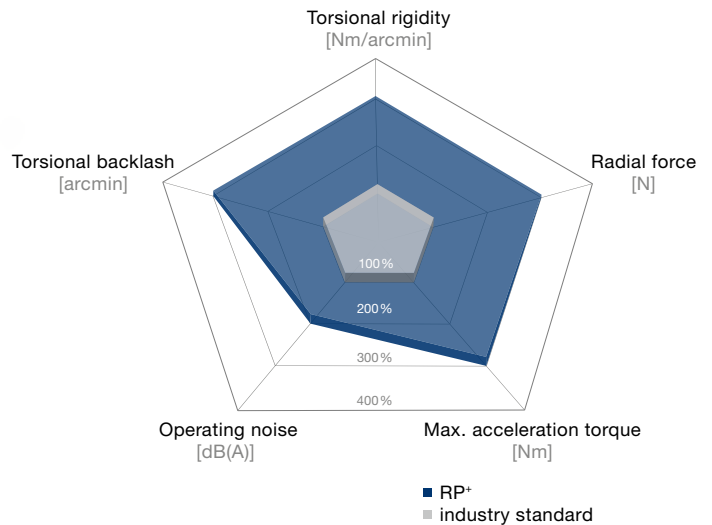

RP+ with rack and pinion



RPK+ with hypoid angle section

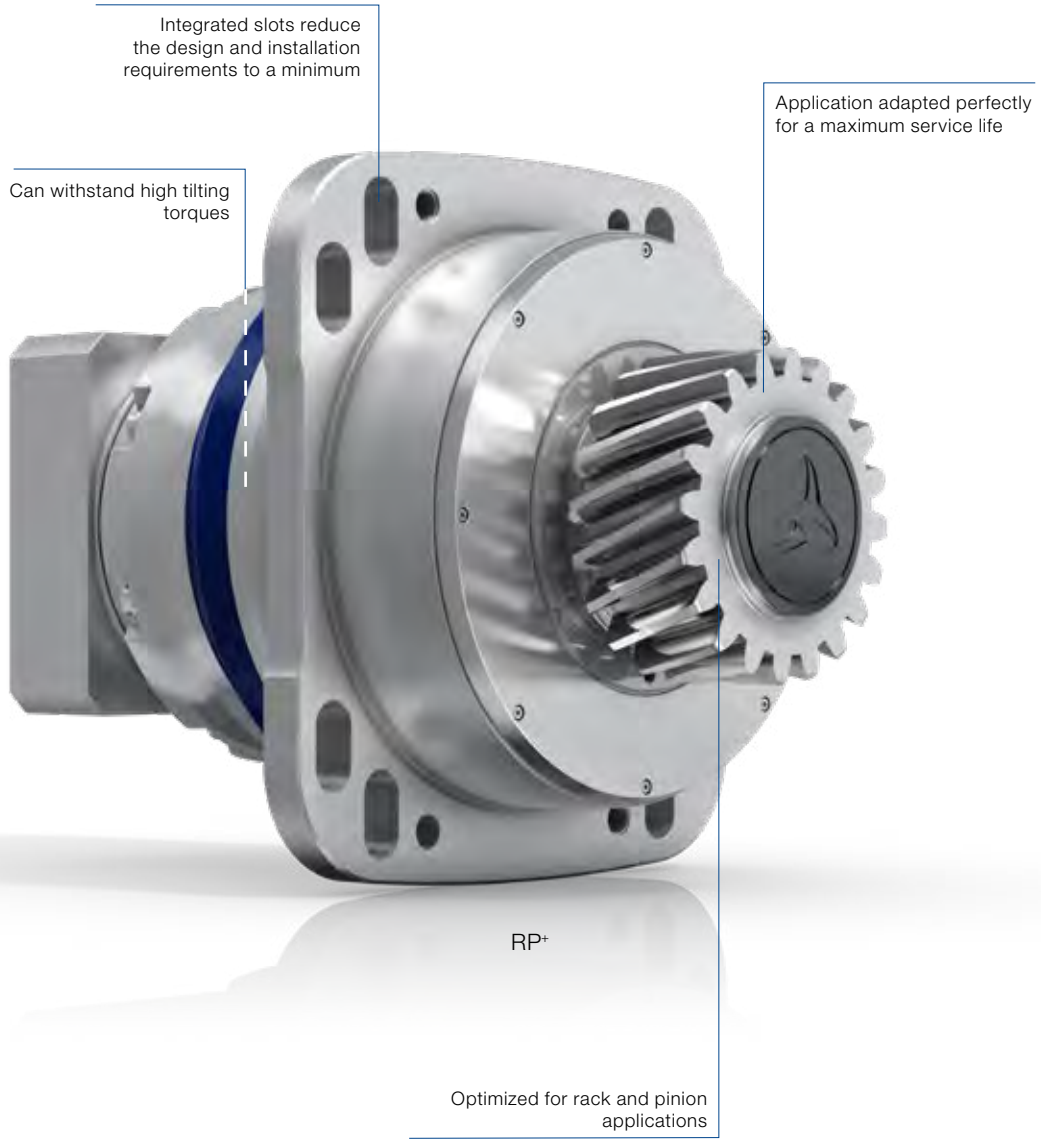

Further information is available in the „alpha Linear Systems“ catalog or online at www.wittenstein-alpha.com



RP+ available as RPM+ servo actuator version (series in an even more compact design)

RP+ 030 MF 1-stage

			1-stage
Ratio	i		4 / 5 / 7 / 10
Max. torque ^{a)}	T_{2a}	<i>Nm</i>	352 – 380
		<i>in.lb</i>	3115 – 3363
Max. acceleration torque (max. 1000 cycles per hour)	T_{2B}	<i>Nm</i>	318 – 380
		<i>in.lb</i>	2815 – 3363
Nominal torque (at n_n)	T_{2N}	<i>Nm</i>	172 – 182
		<i>in.lb</i>	1522 – 1611
Emergency stop torque (permitted 1000 times during the service life of the gearbox)	T_{2Not}	<i>Nm</i>	625
		<i>in.lb</i>	5532
Thermal speed limit (with 20°C ambient temperature and 10% torque utilization) ^{b)}	n_{1T}	<i>rpm</i>	2000 – 2800
Max. input speed	n_{1Max}	<i>rpm</i>	5500
Max. torsional backlash	j_t	<i>arcmin</i>	Standard ≤ 3 / Reduced ≤ 1
Torsional rigidity	C_{t21}	<i>Nm/arcmin</i>	62 – 86
		<i>in.lb/arcmin</i>	549 – 761
Max. tilting moment	M_{2KMax}	<i>Nm</i>	1800
		<i>in.lb</i>	15931
Operating noise ^{c)}	L_{PA}	<i>dB(A)</i>	≤ 61
Lubrication			Lubricated for life
Clamping hub diameter		<i>mm</i>	19 – 38

^{a)} Application-specific design with cymex® – www.wittenstein-cymex.com

^{b)} For higher ambient temperatures, please reduce input speed

^{c)} At reference ratio and reference speed. Ratio-specific values available in cymex®.

1-stage

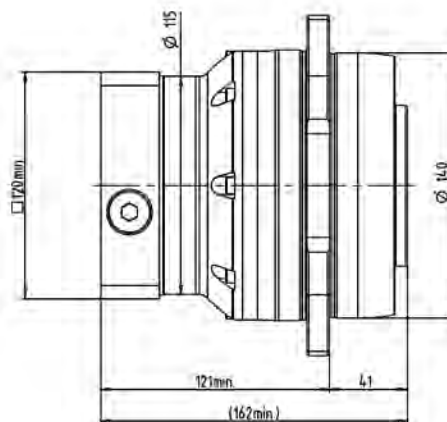
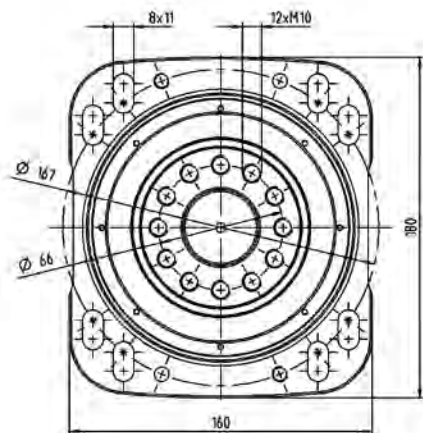

			1-stage
Ratio	i		4 / 5 / 7 / 10
Max. torque ^{a)}	T_{2a}	Nm	720 – 1120
		in.lb	6373 – 9913
Max. acceleration torque (max. 1000 cycles per hour)	T_{2B}	Nm	540 – 700
		in.lb	4779 – 6196
Nominal torque (at n_n)	T_{2N}	Nm	272 – 318
		in.lb	2408 – 2810
Emergency stop torque (permitted 1000 times during the service life of the gearbox)	T_{2Not}	Nm	1563
		in.lb	13829
Thermal speed limit (with 20°C ambient temperature and 10% torque utilization) ^{b)}	n_{TT}	rpm	2500 – 3200
Max. input speed	n_{1Max}	rpm	5000
Max. torsional backlash	j_t	arcmin	Standard ≤ 3 / Reduced ≤ 1
Torsional rigidity	C_{t21}	Nm/arcmin	123 – 190
		in.lb/arcmin	1089 – 1682
Max. tilting moment	M_{2KMax}	Nm	3600
		in.lb	31863
Operating noise ^{c)}	L_{PA}	dB(A)	≤ 61
Lubrication			Lubricated for life
Clamping hub diameter		mm	24 – 48

^{a)} Application-specific design with cymex® – www.wittenstein-cymex.com
^{b)} For higher ambient temperatures, please reduce input speed
^{c)} At reference ratio and reference speed. Ratio-specific values available in cymex®.

1-stage

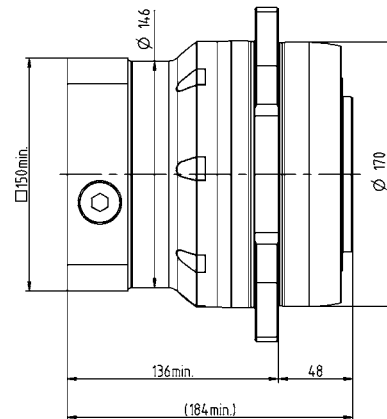
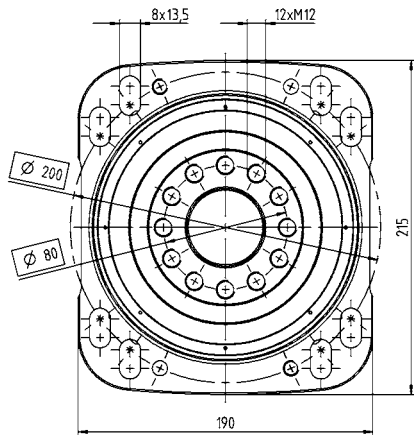

RP+ 050 MF 1-stage

			1-stage
Ratio	i		4 / 5 / 7 / 10
Max. torque ^{a)}	T_{2a}	Nm	2240 – 2560
		$in.lb$	19826 – 22658
Max. acceleration torque (max. 1000 cycles per hour)	T_{2B}	Nm	1400 – 1600
		$in.lb$	12391 – 14161
Nominal torque (at n_n)	T_{2N}	Nm	725 – 927
		$in.lb$	6419 – 8203
Emergency stop torque (permitted 1000 times during the service life of the gearbox)	T_{2Not}	Nm	3204 – 3438
		$in.lb$	28357 – 30425
Thermal speed limit (with 20°C ambient temperature and 10% torque utilization) ^{b)}	n_{1T}	rpm	1500 – 2300
Max. input speed	n_{1Max}	rpm	4500
Max. torsional backlash	j_t	$arcmin$	Standard ≤ 3 / Reduced ≤ 1
Torsional rigidity	C_{t21}	$Nm/arcmin$	445 – 610
		$in.lb/arcmin$	3939 – 5399
Max. tilting moment	M_{2KMax}	Nm	11000
		$in.lb$	97359
Operating noise ^{c)}	L_{PA}	$dB(A)$	≤ 66
Lubrication			Lubricated for life
Clamping hub diameter		mm	38 – 48

^{a)} Application-specific design with cymex® – www.wittenstein-cymex.com

^{b)} For higher ambient temperatures, please reduce input speed

^{c)} At reference ratio and reference speed. Ratio-specific values available in cymex®.

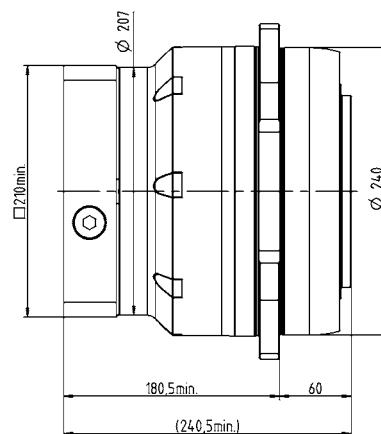
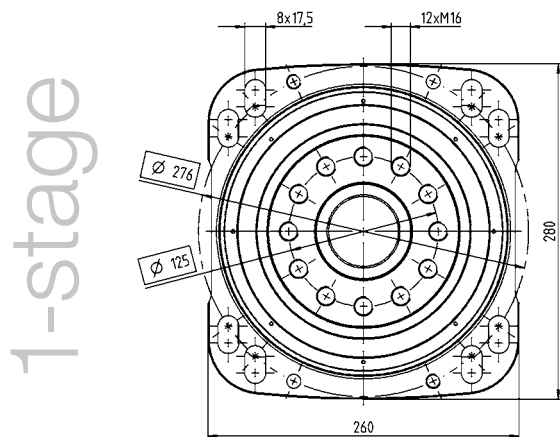



Planetary gearboxes

RP+ 030 MA 1-/2-stage

			1-stage	2-stage
Ratio	i		5.5	16 / 22 / 27.5 / 38.5 / 55
Max. torque ^{a)}	T_{2a}	<i>Nm</i>	583	583
		<i>in.lb</i>	5160	5160
Max. acceleration torque (max. 1000 cycles per hour)	T_{2B}	<i>Nm</i>	530	530
		<i>in.lb</i>	4691	4691
Nominal torque (at n_n)	T_{2N}	<i>Nm</i>	243	315 – 432
		<i>in.lb</i>	2150	2788 – 3823
Emergency stop torque (permitted 1000 times during the service life of the gearbox)	T_{2Not}	<i>Nm</i>	1200	1200
		<i>in.lb</i>	10621	10621
Thermal speed limit (with 20°C ambient temperature and 10% torque utilization) ^{b)}	n_{TT}	<i>rpm</i>	2000	3000
Max. input speed	n_{1Max}	<i>rpm</i>	5500	7500
Max. torsional backlash	j_t	<i>arcmin</i>	Standard ≤ 1	Standard ≤ 1
Torsional rigidity	C_{t21}	<i>Nm/arcmin</i>	105	100 – 105
		<i>in.lb/arcmin</i>	929	885 – 929
Max. tilting moment	M_{2KMax}	<i>Nm</i>	1800	1800
		<i>in.lb</i>	15931	15931
Operating noise ^{c)}	L_{PA}	<i>dB(A)</i>	≤ 65	≤ 58
Lubrication			Lubricated for life	Lubricated for life
Clamping hub diameter		<i>mm</i>	19 – 38	19 – 24

^{a)} Application-specific design with cymex® – www.wittenstein-cymex.com

^{b)} For higher ambient temperatures, please reduce input speed

^{c)} At reference ratio and reference speed. Ratio-specific values available in cymex®.

1-stage

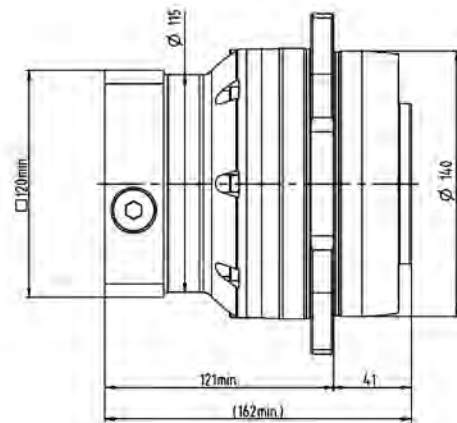
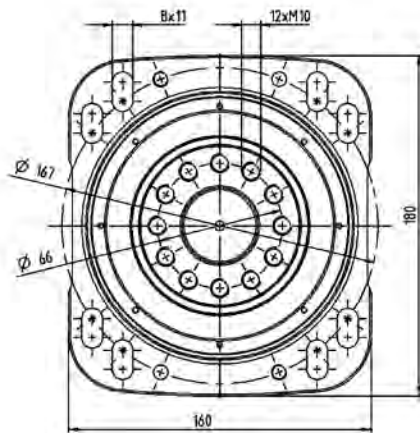

2-stage

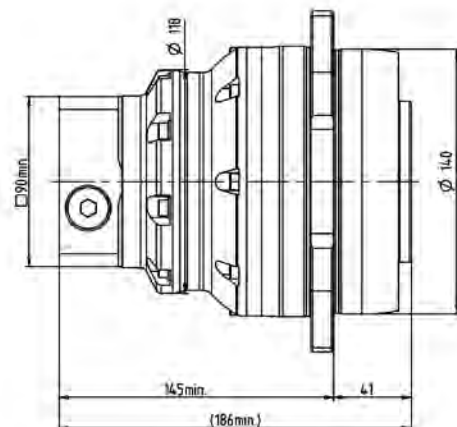
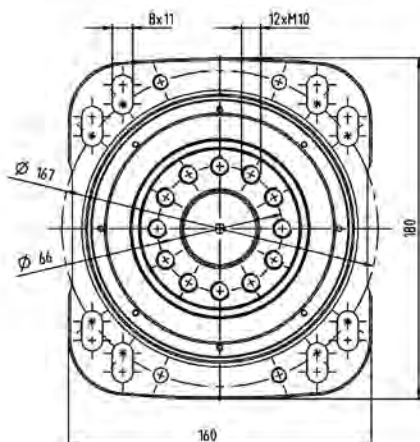

			3-stage
Ratio	i		66 / 88 / 110 / 154 / 220
Max. torque ^{a)}	T_{2a}	Nm	583
		$in.lb$	5160
Max. acceleration torque (max. 1000 cycles per hour)	T_{2B}	Nm	530
		$in.lb$	4691
Nominal torque (at n_n)	T_{2N}	Nm	284 – 397
		$in.lb$	2513 – 3513
Emergency stop torque (permitted 1000 times during the service life of the gearbox)	T_{2Not}	Nm	1200
		$in.lb$	10621
Thermal speed limit (with 20°C ambient temperature and 10% torque utilization) ^{b)}	n_{1T}	rpm	3000
Max. input speed	n_{1Max}	rpm	7500
Max. torsional backlash	j_t	$arcmin$	Standard ≤ 1
Torsional rigidity	C_{t21}	$Nm/arcmin$	95
		$in.lb/arcmin$	841
Max. tilting moment	M_{2KMax}	Nm	1800
		$in.lb$	15931
Operating noise ^{c)}	L_{PA}	$dB(A)$	≤ 56
Lubrication			Lubricated for life
Clamping hub diameter		mm	19

^{a)} Application-specific design with cymex® – www.wittenstein-cymex.com
^{b)} For higher ambient temperatures, please reduce input speed
^{c)} At reference ratio and reference speed. Ratio-specific values available in cymex®.

3-stage

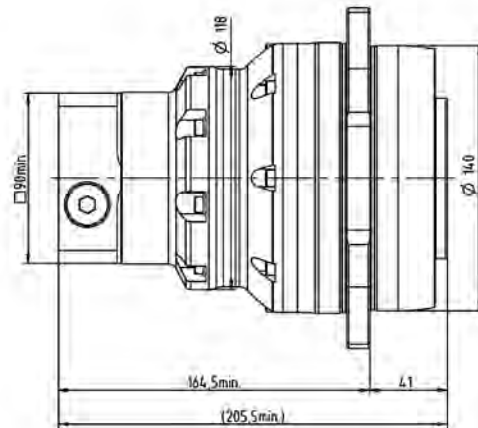
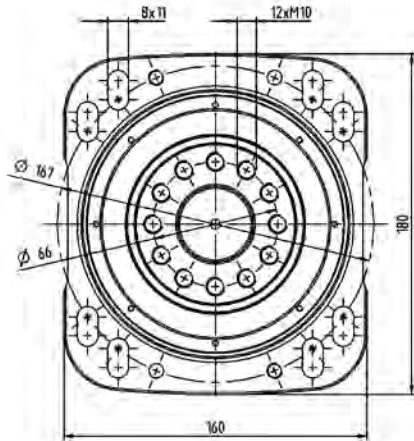

RP+ 040 MA 1-/2-stage

			1-stage	2-stage
Ratio	i		5.5	16 / 22 / 27.5 / 38.5 / 55
Max. torque ^{a)}	T_{2a}	Nm	1402	1270 – 1402
		in.lb	12406	11243 – 12406
Max. acceleration torque (max. 1000 cycles per hour)	T_{2B}	Nm	950	950
		in.lb	8408	8408
Nominal torque (at n_n)	T_{2N}	Nm	417	476 – 653
		in.lb	3695	4217 – 5779
Emergency stop torque (permitted 1000 times during the service life of the gearbox)	T_{2Not}	Nm	2865	2420 – 2613
		in.lb	25358	21416 – 25358
Thermal speed limit (with 20°C ambient temperature and 10% torque utilization) ^{b)}	n_{1T}	rpm	2500	4000 – 4100
Max. input speed	n_{1Max}	rpm	5000	6250
Max. torsional backlash	j_t	arcmin	Standard ≤ 1	Standard ≤ 1
Torsional rigidity	C_{t21}	Nm/arcmin	220	220
		in.lb/arcmin	1947	1947
Max. tilting moment	M_{2KMax}	Nm	3600	3600
		in.lb	31863	31863
Operating noise ^{c)}	L_{PA}	dB(A)	≤ 63	≤ 61
Lubrication			Lubricated for life	Lubricated for life
Clamping hub diameter		mm	38 – 48	24 – 38

^{a)} Application-specific design with cymex® – www.wittenstein-cymex.com

^{b)} For higher ambient temperatures, please reduce input speed

^{c)} At reference ratio and reference speed. Ratio-specific values available in cymex®.

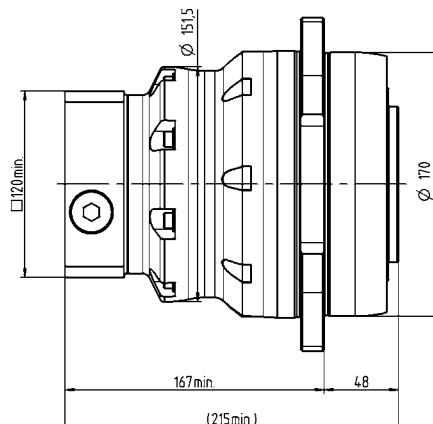
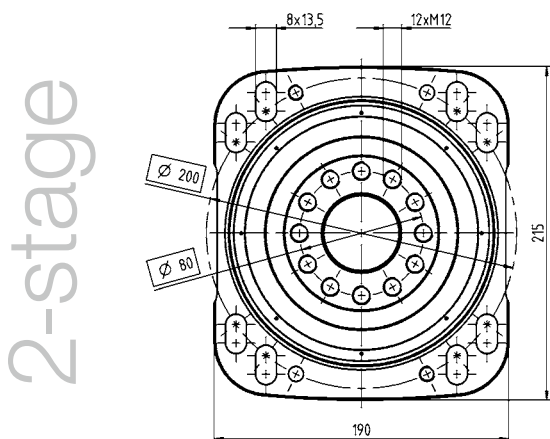
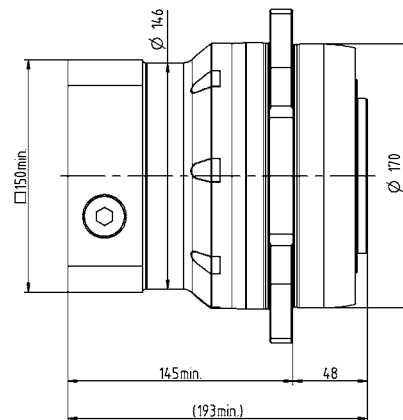
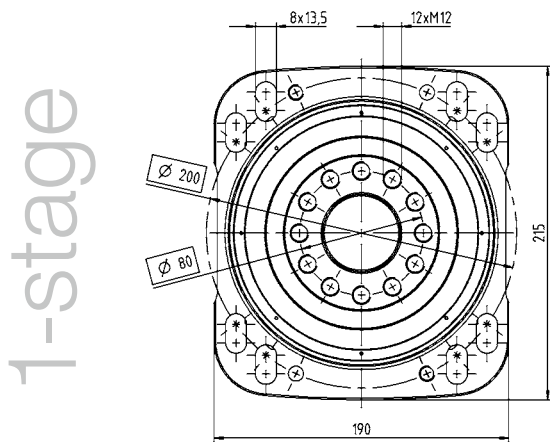

			3-stage
Ratio	i		66 / 88 / 110 / 154 / 220
Max. torque ^{a)}	T_{2a}	<i>Nm</i>	1402
		<i>in.lb</i>	12406
Max. acceleration torque (max. 1000 cycles per hour)	T_{2B}	<i>Nm</i>	950
		<i>in.lb</i>	8408
Nominal torque (at n_n)	T_{2N}	<i>Nm</i>	690 – 760
		<i>in.lb</i>	6103 – 6727
Emergency stop torque (permitted 1000 times during the service life of the gearbox)	T_{2Not}	<i>Nm</i>	2865
		<i>in.lb</i>	25358
Thermal speed limit (with 20°C ambient temperature and 10% torque utilization) ^{b)}	n_{TT}	<i>rpm</i>	4100
Max. input speed	n_{1Max}	<i>rpm</i>	6250
Max. torsional backlash	j_t	<i>arcmin</i>	Standard ≤ 1
Torsional rigidity	C_{t21}	<i>Nm/arcmin</i>	205
		<i>in.lb/arcmin</i>	1814
Max. tilting moment	M_{2KMax}	<i>Nm</i>	3600
		<i>in.lb</i>	31863
Operating noise ^{c)}	L_{PA}	<i>dB(A)</i>	≤ 58
Lubrication			Lubricated for life
Clamping hub diameter		<i>mm</i>	24

^{a)} Application-specific design with cymex® – www.wittenstein-cymex.com
^{b)} For higher ambient temperatures, please reduce input speed
^{c)} At reference ratio and reference speed. Ratio-specific values available in cymex®.

3-stage

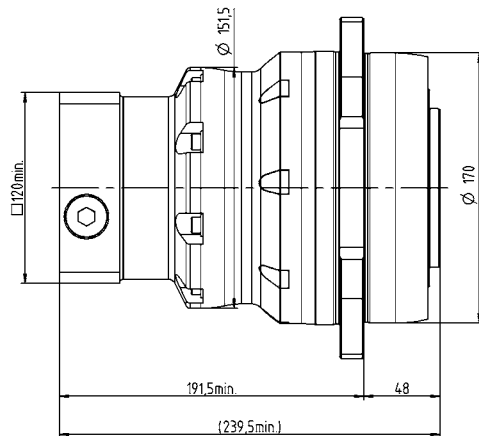
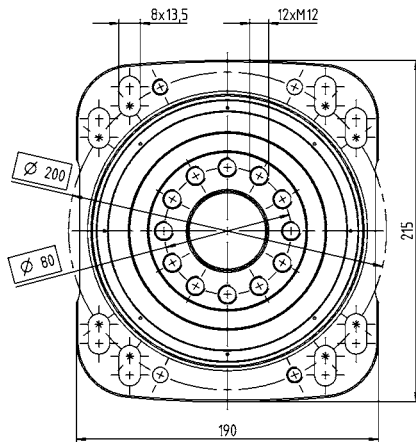

RP+ 050 MA 1-/2-stage

			1-stage	2-stage
Ratio	i		5.5	16 / 22 / 27.5 / 38.5 / 55
Max. torque ^{a)}	T_{2a}	Nm	3822	3518 – 3822
		in.lb	33826	28323 – 33826
Max. acceleration torque (max. 1000 cycles per hour)	T_{2B}	Nm	3100	2000 – 3100
		in.lb	27437	17702 – 27437
Nominal torque (at n_n)	T_{2N}	Nm	1167	1174 – 1977
		in.lb	10326	10387 – 17501
Emergency stop torque (permitted 1000 times during the service life of the gearbox)	T_{2Not}	Nm	6250	7150
		in.lb	55318	63283
Thermal speed limit (with 20°C ambient temperature and 10% torque utilization) ^{b)}	n_{1T}	rpm	1500	3100 – 3300
Max. input speed	n_{1Max}	rpm	4500	5625
Max. torsional backlash	j_t	arcmin	Standard ≤ 1	Standard ≤ 1
Torsional rigidity	C_{t21}	Nm/arcmin	730	670 – 730
		in.lb/arcmin	6461	5930 – 6461
Max. tilting moment	M_{2KMax}	Nm	11000	11000
		in.lb	97359	97359
Operating noise ^{c)}	L_{PA}	dB(A)	≤ 66	≤ 64
Lubrication			Lubricated for life	Lubricated for life
Clamping hub diameter		mm	48	38 – 48

^{a)} Application-specific design with cymex® – www.wittenstein-cymex.com

^{b)} For higher ambient temperatures, please reduce input speed

^{c)} At reference ratio and reference speed. Ratio-specific values available in cymex®.

1-stage

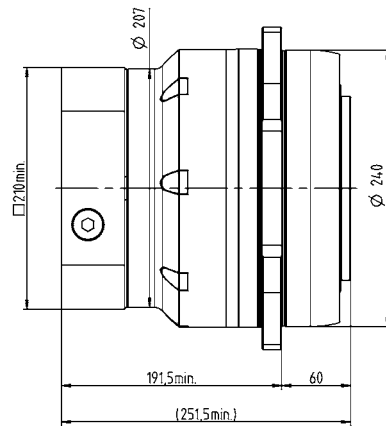
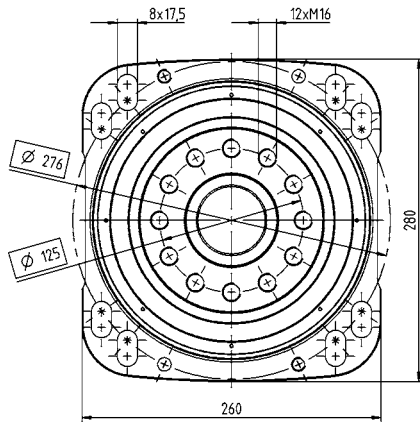

2-stage

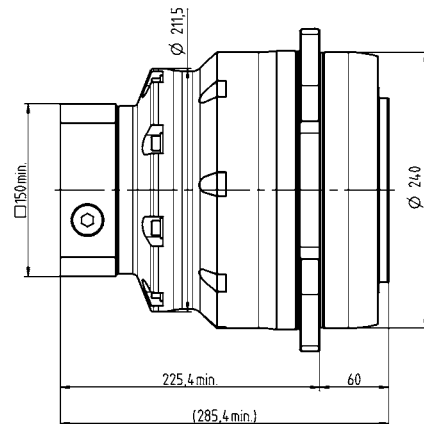
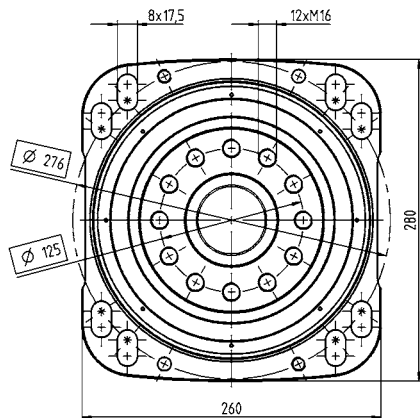

			3-stage
Ratio	i		66 / 88 / 110 / 154 / 220
Max. torque ^{a)}	T_{2a}	<i>Nm</i>	3023
		<i>in.lb</i>	26757
Max. acceleration torque (max. 1000 cycles per hour)	T_{2B}	<i>Nm</i>	2600
		<i>in.lb</i>	23012
Nominal torque (at n_n)	T_{2N}	<i>Nm</i>	1602 – 2080
		<i>in.lb</i>	14182 – 18410
Emergency stop torque (permitted 1000 times during the service life of the gearbox)	T_{2Not}	<i>Nm</i>	8125
		<i>in.lb</i>	71913
Thermal speed limit (with 20°C ambient temperature and 10% torque utilization) ^{b)}	n_{TT}	<i>rpm</i>	3300
Max. input speed	n_{1Max}	<i>rpm</i>	5625
Max. torsional backlash	j_t	<i>arcmin</i>	Standard ≤ 1
Torsional rigidity	C_{t21}	<i>Nm/arcmin</i>	650
		<i>in.lb/arcmin</i>	5753
Max. tilting moment	M_{2KMax}	<i>Nm</i>	11000
		<i>in.lb</i>	97359
Operating noise ^{c)}	L_{PA}	<i>dB(A)</i>	≤ 59
Lubrication			Lubricated for life
Clamping hub diameter		<i>mm</i>	38

^{a)} Application-specific design with cymex® – www.wittenstein-cymex.com

^{b)} For higher ambient temperatures, please reduce input speed

^{c)} At reference ratio and reference speed. Ratio-specific values available in cymex®.

3-stage

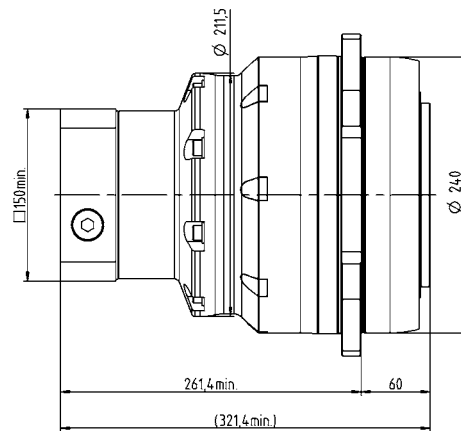
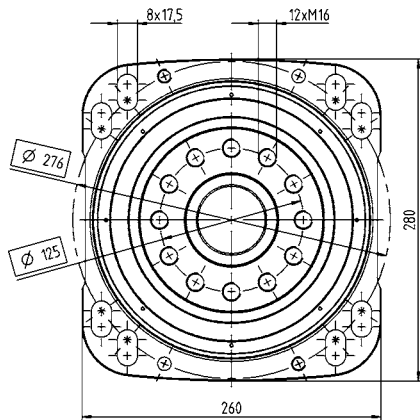

RP+ 060 MA 1-/2-stage

			1-stage	2-stage
Ratio	i		5.5	22 / 27.5 / 38.5 / 55
Max. torque ^{a)}	T_{2a}	<i>Nm</i>	7360	6240 – 7535
		<i>in.lb</i>	65142	55229 – 66691
Max. acceleration torque (max. 1000 cycles per hour)	T_{2B}	<i>Nm</i>	4600	3900 – 5500
		<i>in.lb</i>	40714	34518 – 48679
Nominal torque (at n_n)	T_{2N}	<i>Nm</i>	2829	3120 – 3530
		<i>in.lb</i>	25035	27614 – 31243
Emergency stop torque (permitted 1000 times during the service life of the gearbox)	T_{2Not}	<i>Nm</i>	10938	15296 – 15333
		<i>in.lb</i>	96806	135377 – 135709
Thermal speed limit (with 20°C ambient temperature and 10% torque utilization ^{b)})	n_{IT}	<i>rpm</i>	1000	2750
Max. input speed	n_{IMax}	<i>rpm</i>	3125	4375
Max. torsional backlash	j_t	<i>arcmin</i>	Standard ≤ 1	Standard $\leq 1,5$
Torsional rigidity	C_{t21}	<i>Nm/arcmin</i>	1200	1200
		<i>in.lb/arcmin</i>	10621	10621
Max. tilting moment	M_{2KMax}	<i>Nm</i>	21000	21000
		<i>in.lb</i>	185867	185867
Operating noise ^{c)}	L_{PA}	<i>dB(A)</i>	≤ 68	≤ 64
Lubrication			Lubricated for life	Lubricated for life
Clamping hub diameter		<i>mm</i>	55	48

^{a)} Application-specific design with cymex® – www.wittenstein-cymex.com

^{b)} For higher ambient temperatures, please reduce input speed

^{c)} At reference ratio and reference speed. Ratio-specific values available in cymex®.

1-stage

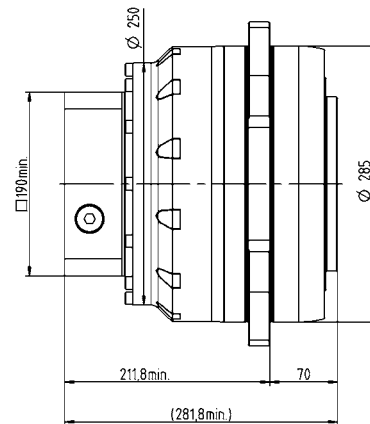
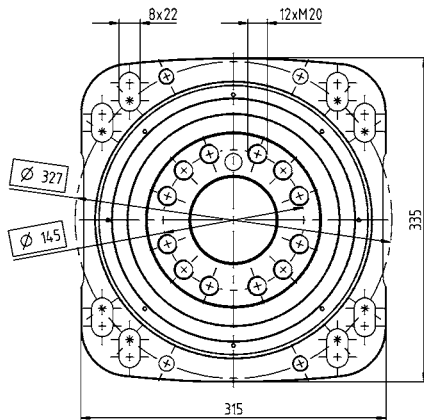

2-stage

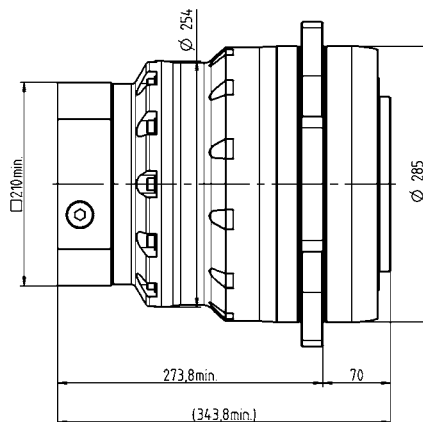
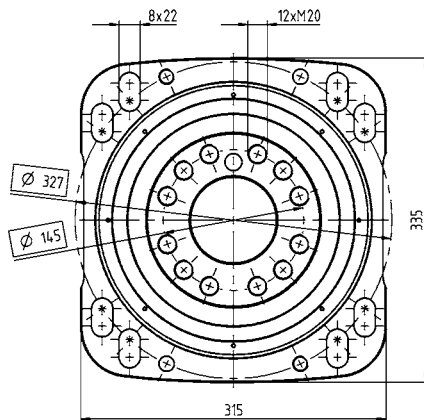

			3-stage
Ratio	i		66 / 88 / 110 / 154 / 220
Max. torque ^{a)}	T_{2a}	<i>Nm</i>	6987
		<i>in.lb</i>	61838
Max. acceleration torque (max. 1000 cycles per hour)	T_{2B}	<i>Nm</i>	5500
		<i>in.lb</i>	48679
Nominal torque (at n_n)	T_{2N}	<i>Nm</i>	2923 – 4196
		<i>in.lb</i>	25869 – 37136
Emergency stop torque (permitted 1000 times during the service life of the gearbox)	T_{2Not}	<i>Nm</i>	15333
		<i>in.lb</i>	135709
Thermal speed limit (with 20°C ambient temperature and 10% torque utilization) ^{b)}	n_{TT}	<i>rpm</i>	2750
Max. input speed	n_{1Max}	<i>rpm</i>	4375
Max. torsional backlash	j_t	<i>arcmin</i>	Standard $\leq 1,5$
Torsional rigidity	C_{t21}	<i>Nm/arcmin</i>	1200
		<i>in.lb/arcmin</i>	10621
Max. tilting moment	M_{2KMax}	<i>Nm</i>	21000
		<i>in.lb</i>	185867
Operating noise ^{c)}	L_{PA}	<i>dB(A)</i>	≤ 59
Lubrication			Lubricated for life
Clamping hub diameter		<i>mm</i>	38

^{a)} Application-specific design with cymex® – www.wittenstein-cymex.com

^{b)} For higher ambient temperatures, please reduce input speed

^{c)} At reference ratio and reference speed. Ratio-specific values available in cymex®.

3-stage

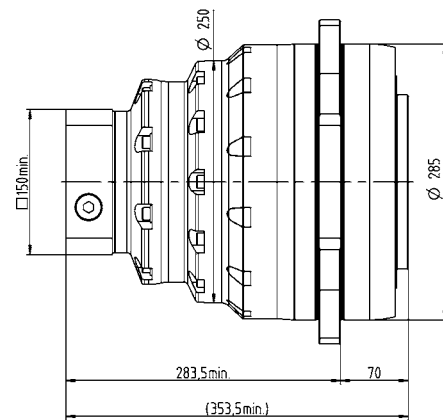
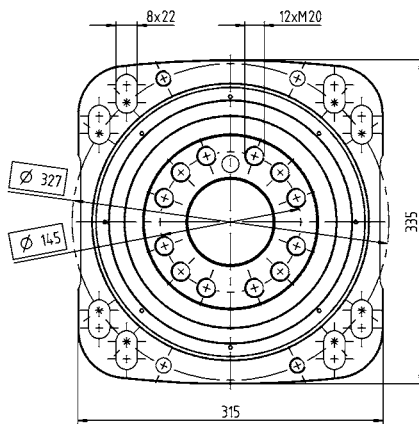

RP+ 080 MA 1-/2-stage

			1-stage	2-stage
Ratio	i		5.5	22 / 27.5 / 38.5 / 55
Max. torque ^{a)}	T_{2a}	<i>Nm</i>	10450	10450
		<i>in.lb</i>	92491	92491
Max. acceleration torque (max. 1000 cycles per hour)	T_{2B}	<i>Nm</i>	8000	7200 – 10000
		<i>in.lb</i>	70806	63726 – 88508
Nominal torque (at n_n)	T_{2N}	<i>Nm</i>	4313	4602 – 4921
		<i>in.lb</i>	38174	40736 – 43558
Emergency stop torque (permitted 1000 times during the service life of the gearbox)	T_{2Not}	<i>Nm</i>	18750	25000
		<i>in.lb</i>	165953	221270
Thermal speed limit (with 20°C ambient temperature and 10% torque utilization ^{b)})	n_{IT}	<i>rpm</i>	900	1950
Max. input speed	n_{IMax}	<i>rpm</i>	3125	4375
Max. torsional backlash	j_t	<i>arcmin</i>	Standard ≤ 1	Standard $\leq 1,5$
Torsional rigidity	C_{t21}	<i>Nm/arcmin</i>	2000	2000
		<i>in.lb/arcmin</i>	17702	17702
Max. tilting moment	M_{2KMax}	<i>Nm</i>	34000	34000
		<i>in.lb</i>	300927	300927
Operating noise ^{c)}	L_{PA}	<i>dB(A)</i>	≤ 68	≤ 65
Lubrication			Lubricated for life	Lubricated for life
Clamping hub diameter		<i>mm</i>	60	48

^{a)} Application-specific design with cymex® – www.wittenstein-cymex.com

^{b)} For higher ambient temperatures, please reduce input speed

^{c)} At reference ratio and reference speed. Ratio-specific values available in cymex®.

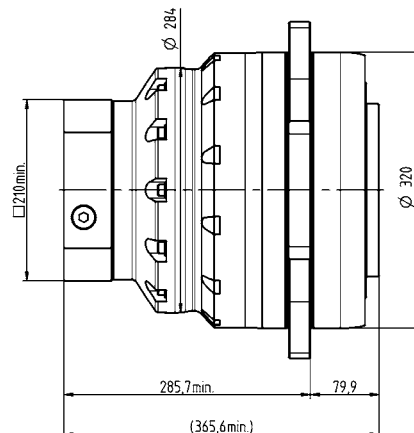
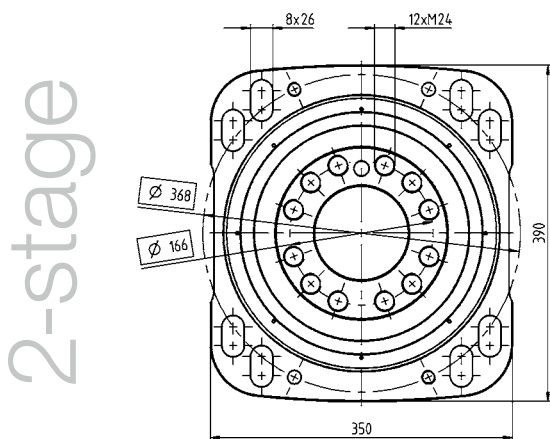
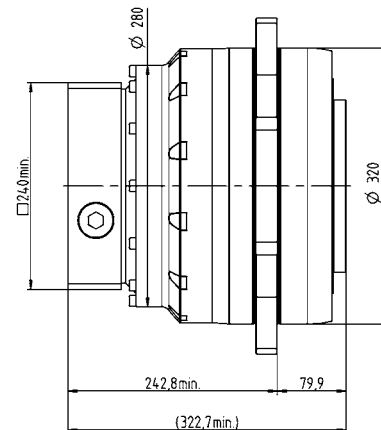
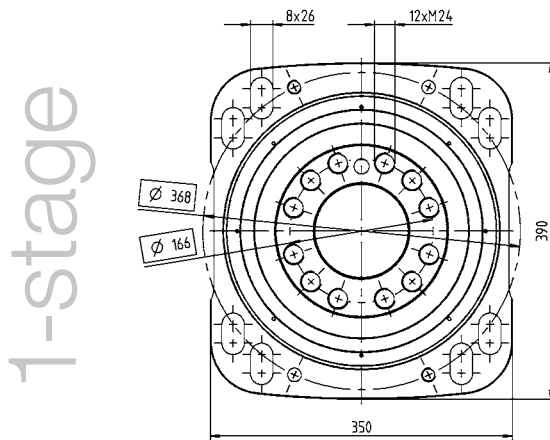

			3-stage
Ratio	i		66 / 88 / 110 / 154 / 220
Max. torque ^{a)}	T_{2a}	<i>Nm</i>	10450
		<i>in.lb</i>	92491
Max. acceleration torque (max. 1000 cycles per hour)	T_{2B}	<i>Nm</i>	10000
		<i>in.lb</i>	88508
Nominal torque (at n_n)	T_{2N}	<i>Nm</i>	4567 – 7308
		<i>in.lb</i>	40418 – 64684
Emergency stop torque (permitted 1000 times during the service life of the gearbox)	T_{2Not}	<i>Nm</i>	25000
		<i>in.lb</i>	221270
Thermal speed limit (with 20°C ambient temperature and 10% torque utilization) ^{b)}	n_{TT}	<i>rpm</i>	1950
Max. input speed	n_{1Max}	<i>rpm</i>	4375
Max. torsional backlash	j_t	<i>arcmin</i>	Standard $\leq 1,5$
Torsional rigidity	C_{t21}	<i>Nm/arcmin</i>	1800
		<i>in.lb/arcmin</i>	15931
Max. tilting moment	M_{2KMax}	<i>Nm</i>	34000
		<i>in.lb</i>	300927
Operating noise ^{c)}	L_{PA}	<i>dB(A)</i>	≤ 62
Lubrication			Lubricated for life
Clamping hub diameter		<i>mm</i>	38 – 48

^{a)} Application-specific design with cymex® – www.wittenstein-cymex.com

^{b)} For higher ambient temperatures, please reduce input speed

^{c)} At reference ratio and reference speed. Ratio-specific values available in cymex®.

3-stage

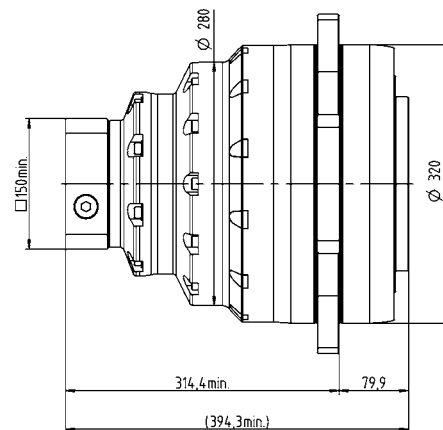
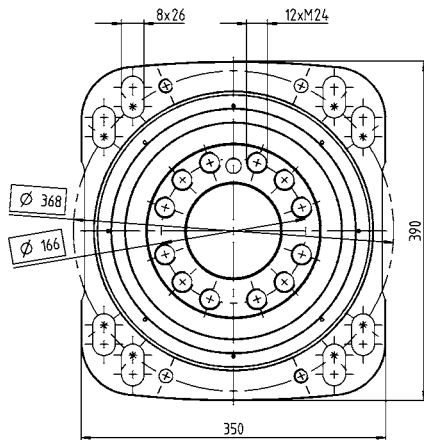





XPK⁺ and RPK⁺ hypoid gearboxes

A new performance standard

XPK⁺ / RPK⁺ – Power and precision in a compact design



New standard now also available as a hypoid version

Both the XP⁺ and RP⁺ Premium planetary gearboxes are now available in a right-angle version with hypoid gearing. The axis offset of hypoid gearboxes allows both higher ratios in one section (ratio $i = 3 - 10$) as well as higher torques compared to bevel gearboxes. The high torque density allows for an extremely compact, space-saving design. The mesh frequency and high torsional rigidity of the gearbox are also extremely impressive since they ensure a higher degree of positioning accuracy and extremely smooth operation.

XPK⁺ and RPK⁺ compared to industry standard

Product highlights

- Max. torsional backlash**
- XPK⁺ ≤ 4 arcmin (Standard)
- ≤ 2 arcmin (Reduced)
- RPK⁺ ≤ 1.3 arcmin
- XPK⁺ and RPK⁺:**
- Range of transmission ratios:** $i = 12 - 5,500$
- High axial and radial forces**
- High torsional rigidity**
- Maximum performance in small installation space**
- Optimized for rack and pinion applications**

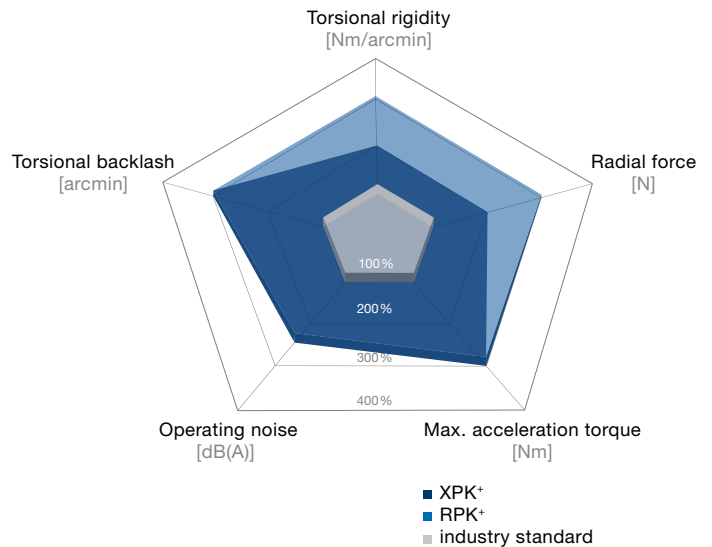

XPK⁺ with pinion and slots



XPK⁺ with pinion, slots and rack

The ideal partnership

Premium Linear Systems with the XPK⁺ or RPK⁺ are used in all applications where the individual requirements far exceed what has previously been possible. Compared to the industry standard, the values of the RPK⁺ have been improved by 150 % on average.

Integrated slots reduce the design and installation requirements to a minimum

High-quality hypoid section with gear ratios of $i = 3 - 10$ in the angle section



RPK⁺ with pinion

Metal bellows coupling incorporated for thermal length compensation and protection of the motor bearing

The pinions are specially adapted to the gearbox and allow the transmission of extremely high feed forces



RPK⁺ with rack and pinion

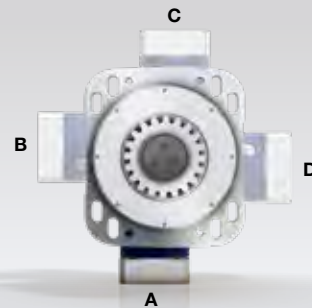

Flexibility during installation

XPK+ 020 MF 2-/3-stage

			2-stage	3-stage
Ratio	i		12 / 16 / 20 / 25 / 28 / 35 / 40 / 50 / 70 / 100	64 / 84 / 100 / 125 / 140 / 175 / 200 / 250 / 280 / 350 / 400 / 500 / 700 / 1000
Max. torque ^{a)}	T_{2a}	<i>Nm</i>	80 – 240	80 – 240
		<i>in.lb</i>	708 – 2124	708 – 2124
Max. acceleration torque (max. 1000 cycles per hour)	T_{2B}	<i>Nm</i>	80 – 180	80 – 180
		<i>in.lb</i>	708 – 1593	708 – 1593
Nominal torque (at n_n)	T_{2N}	<i>Nm</i>	60 – 75	60 – 90
		<i>in.lb</i>	531 – 664	531 – 797
Emergency stop torque (permitted 1000 times during the service life of the gearbox)	T_{2Not}	<i>Nm</i>	160 – 350	160 – 350
		<i>in.lb</i>	1416 – 3098	1416 – 3098
Thermal speed limit (with 20°C ambient temperature and 10% torque utilization) ^{b)}	n_{IT}	<i>rpm</i>	3000 – 3800	5000 – 5500
Max. input speed	n_{1Max}	<i>rpm</i>	7500	6000
Max. torsional backlash	j_t	<i>arcmin</i>	Standard ≤ 5 / Reduced ≤ 3	Standard ≤ 5 / Reduced ≤ 3
Torsional rigidity	C_{t21}	<i>Nm/arcmin</i>	12 – 14	11 – 15
		<i>in.lb/arcmin</i>	106 – 124	97 – 133
Max. tilting moment	M_{2KMax}	<i>Nm</i>	675	675
		<i>in.lb</i>	5974	5974
Operating noise ^{c)}	L_{PA}	<i>dB(A)</i>	≤ 66	≤ 66
Lubrication			Lubricated for life	Lubricated for life
Clamping hub diameter		<i>mm</i>	14 – 19	11 – 14

^{a)} Application-specific design with cymex® – www.wittenstein-cymex.com

^{b)} For higher ambient temperatures, please reduce input speed

^{c)} At reference ratio and reference speed. Ratio-specific values available in cymex®.

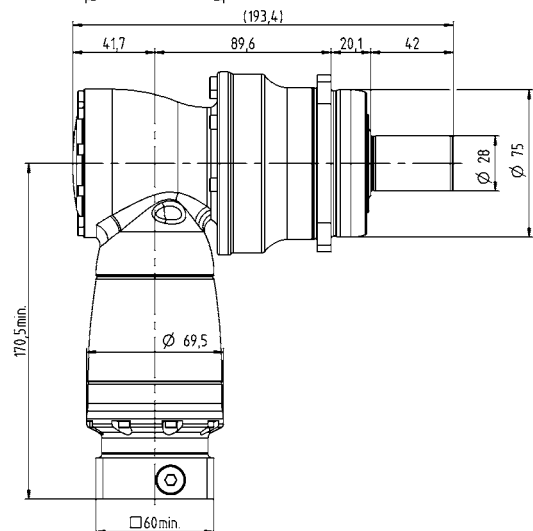
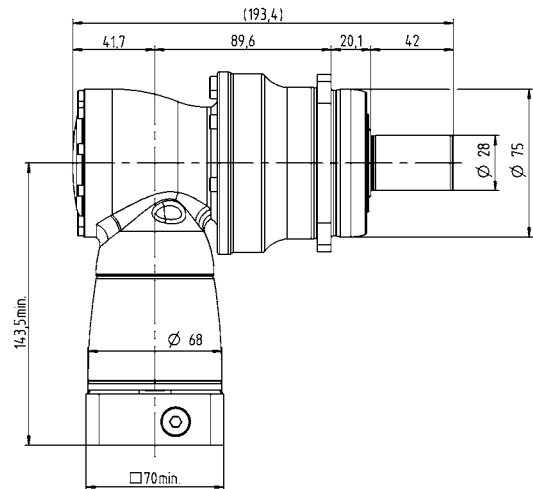
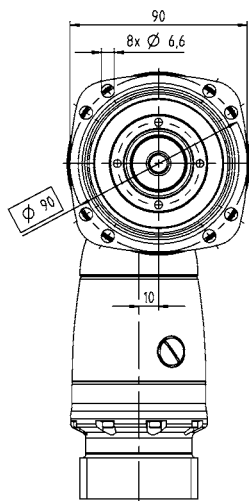
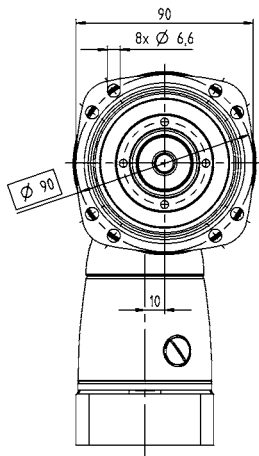

2-stage

3-stage

			2-stage	3-stage
Ratio	i		12 / 16 / 20 / 25 / 28 / 35 / 40 / 50 / 70 / 100	64 / 84 / 100 / 125 / 140 / 175 / 200 / 250 / 280 / 350 / 400 / 500 / 700 / 1000
Max. torque ^{a)}	T_{2a}	Nm	200 – 470	200 – 470
		in.lb	1770 – 4160	1770 – 4160
Max. acceleration torque (max. 1000 cycles per hour)	T_{2B}	Nm	200 – 420	200 – 420
		in.lb	1770 – 3717	1770 – 3717
Nominal torque (at n_n)	T_{2N}	Nm	120 – 170	120 – 210
		in.lb	1062 – 1505	1062 – 1859
Emergency stop torque (permitted 1000 times during the service life of the gearbox)	T_{2Not}	Nm	380 – 781	380 – 781
		in.lb	3363 – 6912	3363 – 6912
Thermal speed limit (with 20°C ambient temperature and 10% torque utilization) ^{b)}	n_{TT}	rpm	3000 – 3800	4500
Max. input speed	n_{1Max}	rpm	7500	6000
Max. torsional backlash	j_t	arcmin	Standard ≤ 4 / Reduced ≤ 2	Standard ≤ 4 / Reduced ≤ 2
Torsional rigidity	C_{t21}	Nm/arcmin	29 – 36	29 – 36
		in.lb/arcmin	257 – 319	257 – 319
Max. tilting moment	M_{2KMax}	Nm	1296	1296
		in.lb	11471	11471
Operating noise ^{c)}	L_{PA}	dB(A)	≤ 68	≤ 68
Lubrication			Lubricated for life	Lubricated for life
Clamping hub diameter		mm	19 – 28	14 – 19

^{a)} Application-specific design with cymex® – www.wittenstein-cymex.com
^{b)} For higher ambient temperatures, please reduce input speed
^{c)} At reference ratio and reference speed. Ratio-specific values available in cymex®.

2-stage

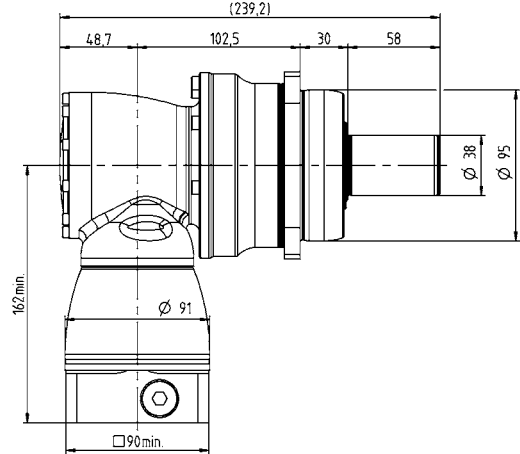
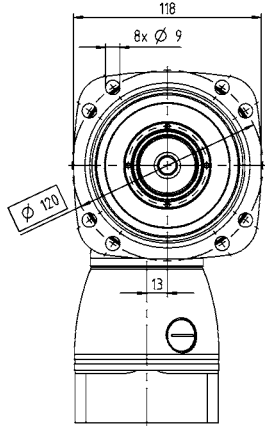

3-stage

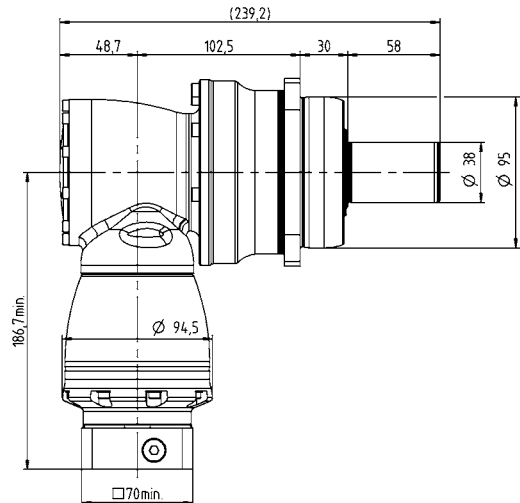
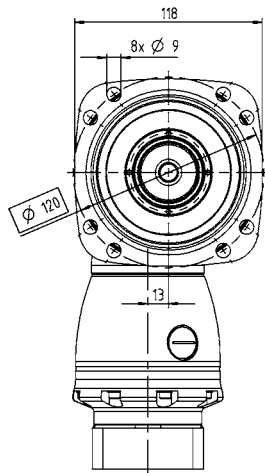

XPK+ 040 MF 2-/3-stage

			2-stage	3-stage
Ratio	i		12 / 16 / 20 / 25 / 28 / 35 / 40 / 50 / 70 / 100	64 / 84 / 100 / 125 / 140 / 175 / 200 / 250 / 280 / 350 / 400 / 500 / 700 / 1000
Max. torque ^{a)}	T_{2a}	Nm	500 – 1020	500 – 1020
		in.lb	4425 – 9028	4425 – 9028
Max. acceleration torque (max. 1000 cycles per hour)	T_{2B}	Nm	500 – 850	500 – 850
		in.lb	4425 – 7523	4425 – 7523
Nominal torque (at n_n)	T_{2N}	Nm	240 – 370	240 – 400
		in.lb	2124 – 3275	2124 – 3540
Emergency stop torque (permitted 1000 times during the service life of the gearbox)	T_{2Not}	Nm	880 – 1820	880 – 1820
		in.lb	7789 – 16108	7789 – 16108
Thermal speed limit (with 20°C ambient temperature and 10% torque utilization) ^{b)}	n_{1T}	rpm	2700 – 3500	4000 – 4200
Max. input speed	n_{1Max}	rpm	5500	4500
Max. torsional backlash	j_t	arcmin	Standard ≤ 4 / Reduced ≤ 2	Standard ≤ 4 / Reduced ≤ 2
Torsional rigidity	C_{t21}	Nm/arcmin	60 – 77	60 – 77
		in.lb/arcmin	531 – 682	531 – 682
Max. tilting moment	M_{2KMax}	Nm	1635	1635
		in.lb	14471	14471
Operating noise ^{c)}	L_{PA}	dB(A)	≤ 70	≤ 70
Lubrication			Lubricated for life	Lubricated for life
Clamping hub diameter		mm	28 – 38	19 – 24

^{a)} Application-specific design with cymex® – www.wittenstein-cymex.com

^{b)} For higher ambient temperatures, please reduce input speed

^{c)} At reference ratio and reference speed. Ratio-specific values available in cymex®.

2-stage

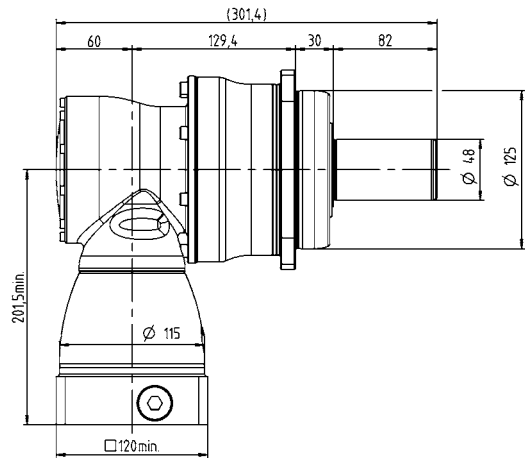
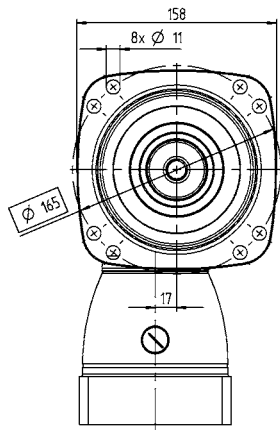

3-stage

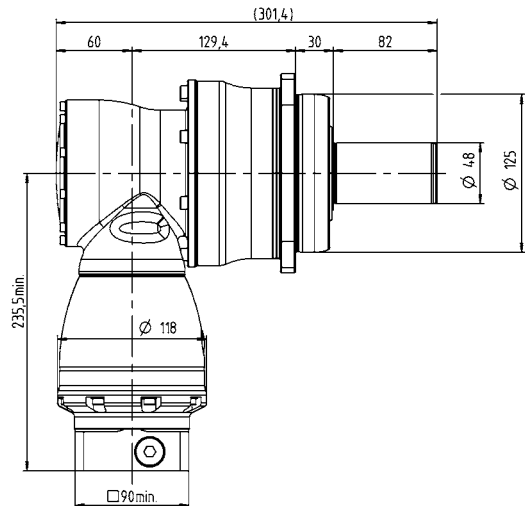
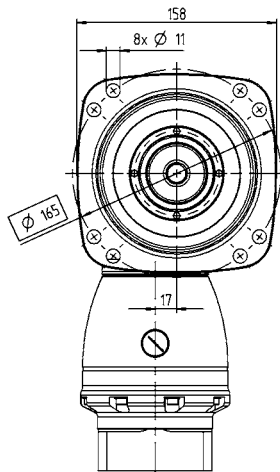

			2-stage	3-stage
Ratio	i		12 / 16 / 20 / 25 / 28 / 35 / 40 / 50 / 70 / 100	64 / 84 / 100 / 125 / 140 / 175 / 200 / 250 / 280 / 350 / 400 / 500 / 700 / 1000
Max. torque ^{a)}	T_{2a}	Nm	840 – 2520	840 – 2520
		in.lb	7435 – 22304	7435 – 22304
Max. acceleration torque (max. 1000 cycles per hour)	T_{2B}	Nm	840 – 2100	840 – 2100
		in.lb	7435 – 18587	7435 – 18587
Nominal torque (at n_n)	T_{2N}	Nm	640 – 750	640 – 1250
		in.lb	5665 – 6638	5665 – 11064
Emergency stop torque (permitted 1000 times during the service life of the gearbox)	T_{2Not}	Nm	1600 – 3505	1600 – 3505
		in.lb	14161 – 31022	14161 – 31022
Thermal speed limit (with 20°C ambient temperature and 10% torque utilization) ^{b)}	n_{TT}	rpm	2300 – 3000	4000 – 4200
Max. input speed	n_{1Max}	rpm	5000	4500
Max. torsional backlash	j_t	arcmin	Standard ≤ 4 / Reduced ≤ 2	Standard ≤ 4 / Reduced ≤ 2
Torsional rigidity	C_{t21}	Nm/arcmin	176 – 224	176 – 226
		in.lb/arcmin	1558 – 1983	1558 – 2000
Max. tilting moment	M_{2KMax}	Nm	3256	3256
		in.lb	28818	28818
Operating noise ^{c)}	L_{PA}	dB(A)	≤ 71	≤ 70
Lubrication			Lubricated for life	Lubricated for life
Clamping hub diameter		mm	38	24 – 38

^{a)} Application-specific design with cymex® – www.wittenstein-cymex.com

^{b)} For higher ambient temperatures, please reduce input speed

^{c)} At reference ratio and reference speed. Ratio-specific values available in cymex®.

2-stage

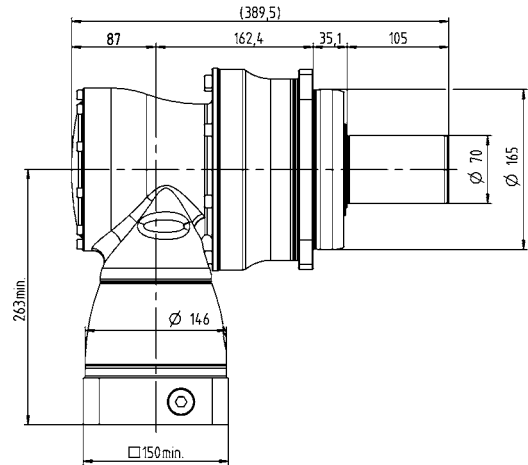
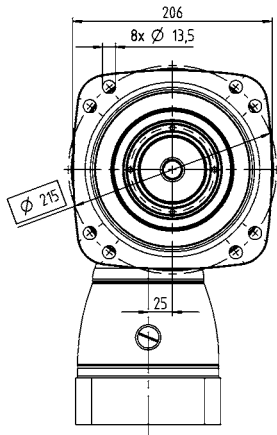

3-stage

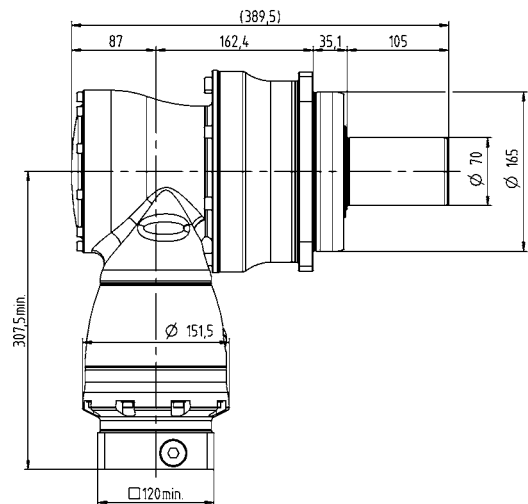
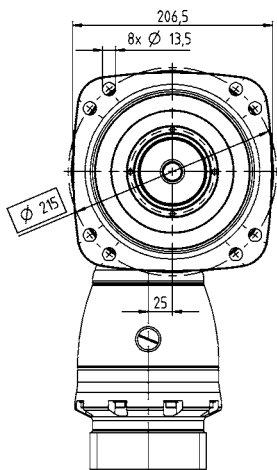

RPK+ 040 MA 3-/4-stage

			3-stage	4-stage
Ratio	i		48 / 66 / 88 / 110 / 137.5 / 154 / 220 / 385	330 / 462 / 577.5 / 770 / 1078 / 1540 / 2695 / 3850 / 5500
Max. torque ^{a)}	T_{2a}	Nm	1100 – 1402	1402
		in.lb	9736 – 12409	12409
Max. acceleration torque (max. 1000 cycles per hour)	T_{2B}	Nm	950	950
		in.lb	8408	8408
Nominal torque (at n_n)	T_{2N}	Nm	675	675
		in.lb	5974	5974
Emergency stop torque (permitted 1000 times during the service life of the gearbox)	T_{2Not}	Nm	1520 – 2613	2090 – 2613
		in.lb	13453 – 23127	18498 – 23127
Thermal speed limit (with 20°C ambient temperature and 10% torque utilization ^{b)})	n_{IT}	rpm	2800 – 3800	4300 – 4400
Max. input speed	n_{1Max}	rpm	7500	6000
Max. torsional backlash	j_t	arcmin	Standard $\leq 1,3$	Standard $\leq 1,3$
Torsional rigidity	C_{t21}	Nm/arcmin	202 – 215	202 – 217
		in.lb/arcmin	1788 – 1903	1788 – 1921
Max. tilting moment	M_{2KMax}	Nm	3600	3600
		in.lb	31863	31863
Operating noise ^{c)}	L_{PA}	dB(A)	≤ 68	≤ 68
Lubrication			Lubricated for life	Lubricated for life
Clamping hub diameter		mm	19 – 28	14 – 19

^{a)} Application-specific design with cymex® – www.wittenstein-cymex.com

^{b)} For higher ambient temperatures, please reduce input speed

^{c)} At reference ratio and reference speed. Ratio-specific values available in cymex®.

3-stage

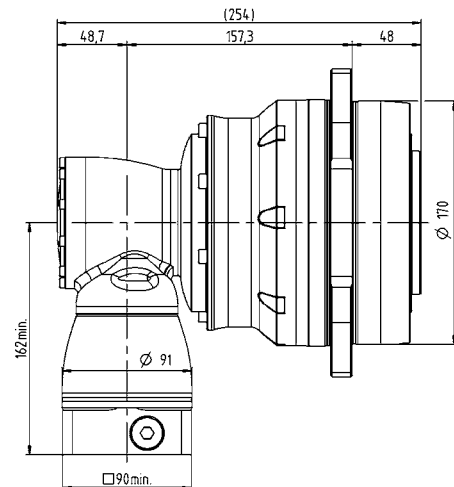
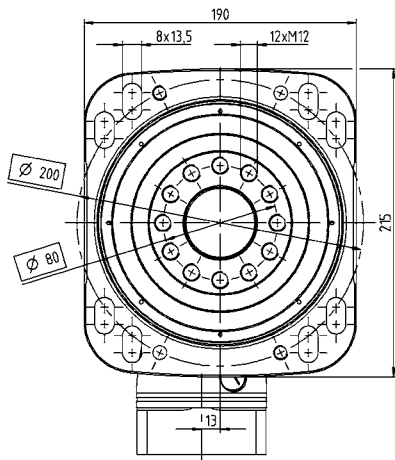

4-stage

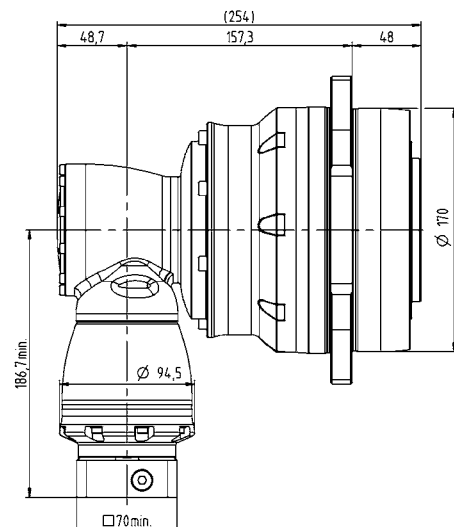
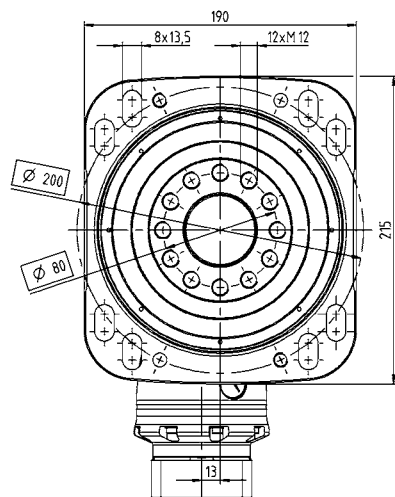

			3-stage	4-stage
Ratio	i		48 / 66 / 88 / 110 / 137.5 / 154 / 220 / 385	330 / 462 / 577.5 / 770 / 1078 / 1540 / 2695 / 3850 / 5500
Max. torque ^{a)}	T_{2a}	Nm	2750 – 3822	3200 – 3822
		in.lb	24340 – 33828	28323 – 33828
Max. acceleration torque (max. 1000 cycles per hour)	T_{2B}	Nm	2720 – 3100	2000 – 3100
		in.lb	24074 – 27437	17702 – 27437
Nominal torque (at n_{2N})	T_{2N}	Nm	1600 – 1650	1400 – 1650
		in.lb	14161 – 14604	12391 – 14604
Emergency stop torque (permitted 1000 times during the service life of the gearbox)	T_{2Not}	Nm	3520 – 7150	4840 – 7150
		in.lb	31155 – 63283	42838 – 63283
Thermal speed limit (with 20°C ambient temperature and 10% torque utilization) ^{b)}	n_{1T}	rpm	2800 – 3600	3800 – 4100
Max. input speed	n_{1Max}	rpm	5500	4500
Max. torsional backlash	j_t	arcmin	Standard $\leq 1,3$	Standard $\leq 1,3$
Torsional rigidity	C_{21}	Nm/arcmin	634 – 687	634 – 689
		in.lb/arcmin	5611 – 6080	5611 – 6098
Max. tilting moment	M_{2KMax}	Nm	11000	11000
		in.lb	97359	97359
Operating noise ^{c)}	L_{PA}	dB(A)	≤ 70	≤ 70
Lubrication			Lubricated for life	Lubricated for life
Clamping hub diameter		mm	28 – 38	19 – 24

^{a)} Application-specific design with cymex® – www.wittenstein-cymex.com

^{b)} For higher ambient temperatures, please reduce input speed

^{c)} At reference ratio and reference speed. Ratio-specific values available in cymex®.

3-stage

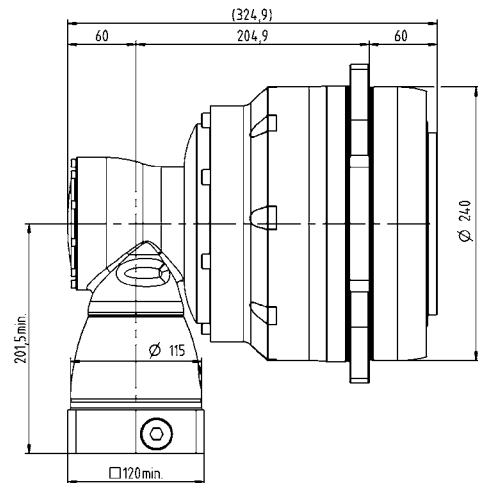
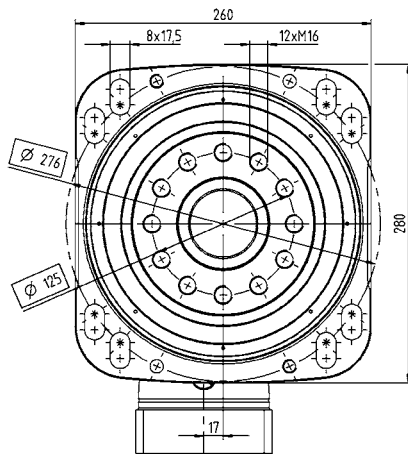

4-stage

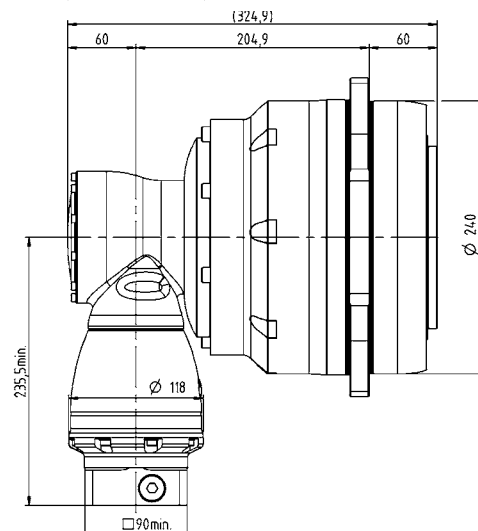
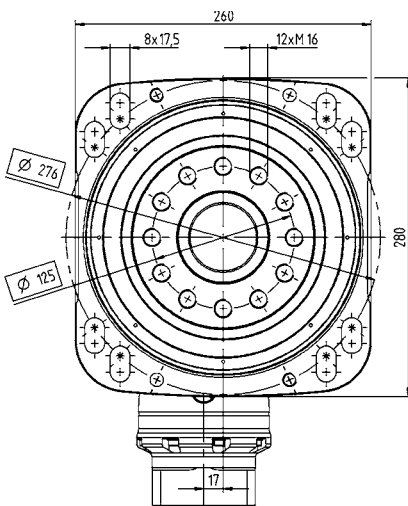

RPK+ 060 MA 3-/4-stage

			3-stage	4-stage
Ratio	i		66 / 88 / 110 / 137.5 / 154 / 220 / 385	330 / 462 / 577.5 / 770 / 1078 / 1540 / 2695 / 3850 / 5500
Max. torque ^{a)}	T_{2a}	Nm	4620 – 7535	6240 – 7535
		in.lb	40891 – 66691	55229 – 66691
Max. acceleration torque (max. 1000 cycles per hour)	T_{2B}	Nm	4620 – 5500	3900 – 5500
		in.lb	30978 – 48679	34518 – 48679
Nominal torque (at n_n)	T_{2N}	Nm	3500	3500
		in.lb	30978	30978
Emergency stop torque (permitted 1000 times during the service life of the gearbox)	T_{2Not}	Nm	8800 – 14575	8800 – 14575
		in.lb	77887 – 129000	77887 – 129000
Thermal speed limit (with 20°C ambient temperature and 10% torque utilization) ^{b)}	n_{IT}	rpm	2300 – 2900	3800 – 4000
Max. input speed	n_{1Max}	rpm	5000	4500
Max. torsional backlash	j_t	arcmin	Standard $\leq 1,8$	Standard $\leq 1,8$
Torsional rigidity	C_{t21}	Nm/arcmin	960 – 1114	953 – 1099
		in.lb/arcmin	8497 – 9860	8435 – 9727
Max. tilting moment	M_{2KMax}	Nm	21000	21000
		in.lb	185867	185867
Operating noise ^{c)}	L_{PA}	dB(A)	≤ 71	≤ 71
Lubrication			Lubricated for life	Lubricated for life
Clamping hub diameter		mm	38	24 – 38

^{a)} Application-specific design with cymex® – www.wittenstein-cymex.com

^{b)} For higher ambient temperatures, please reduce input speed

^{c)} At reference ratio and reference speed. Ratio-specific values available in cymex®.

3-stage

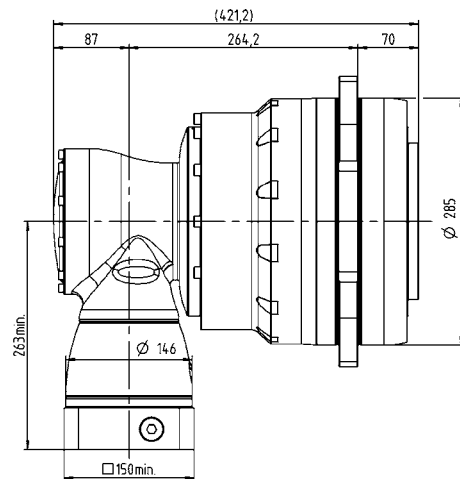
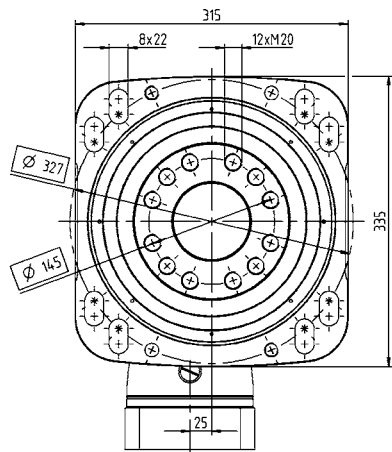

4-stage

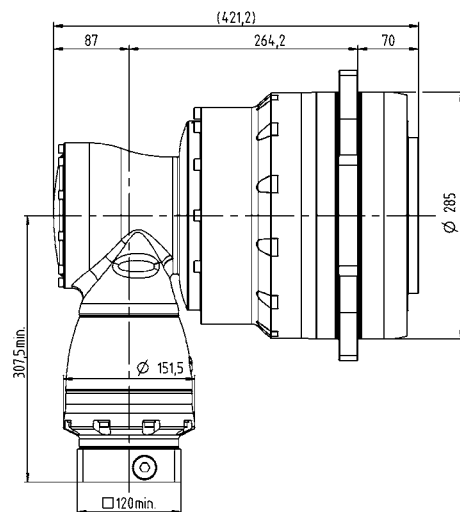
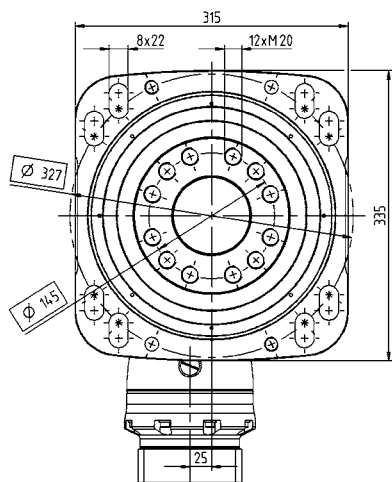

			3-stage	4-stage
Ratio	i		66 / 88 / 110 / 137.5 / 154 / 220 / 385	330 / 462 / 577.5 / 770 / 1078 / 1540 / 2695 / 3850 / 5500
Max. torque ^{a)}	T_{2a}	Nm	10340 – 10450	10450
		in.lb	91517 – 92491	92491
Max. acceleration torque (max. 1000 cycles per hour)	T_{2B}	Nm	10000	7200 – 10000
		in.lb	88508	63726 – 88508
Nominal torque (at n_{2N})	T_{2N}	Nm	5400	5400
		in.lb	47794	47794
Emergency stop torque (permitted 1000 times during the service life of the gearbox)	T_{2Not}	Nm	19800 – 25000	19800 – 25000
		in.lb	175246 – 221270	175246 – 221270
Thermal speed limit (with 20°C ambient temperature and 10% torque utilization) ^{b)}	n_{1T}	rpm	1800 – 3100	3300 – 3600
Max. input speed	n_{1Max}	rpm	4500	4000
Max. torsional backlash	j_t	arcmin	Standard $\leq 1,8$	Standard $\leq 1,8$
Torsional rigidity	C_{21}	Nm/arcmin	1747 – 1901	1735 – 1879
		in.lb/arcmin	15462 – 16825	15356 – 16631
Max. tilting moment	M_{2KMax}	Nm	34000	34000
		in.lb	300927	300927
Operating noise ^{c)}	L_{PA}	dB(A)	≤ 71	≤ 71
Lubrication			Lubricated for life	Lubricated for life
Clamping hub diameter		mm	48	38 – 48

^{a)} Application-specific design with cymex® – www.wittenstein-cymex.com
^{b)} For higher ambient temperatures, please reduce input speed
^{c)} At reference ratio and reference speed. Ratio-specific values available in cymex®.

3-stage

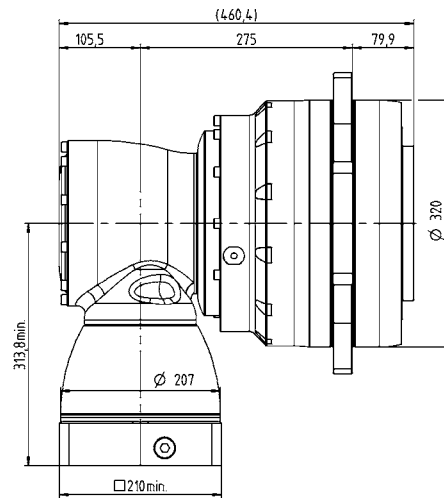
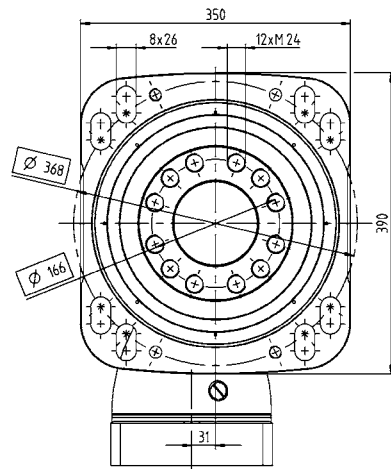

4-stage

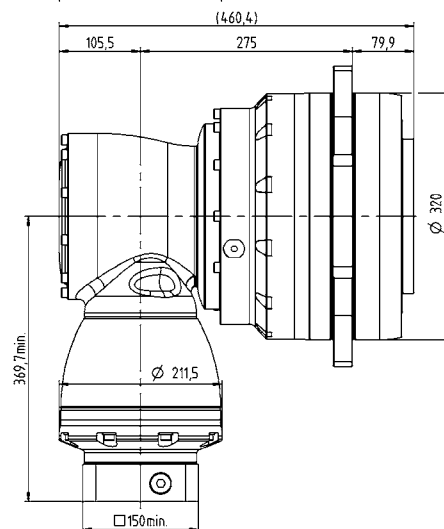
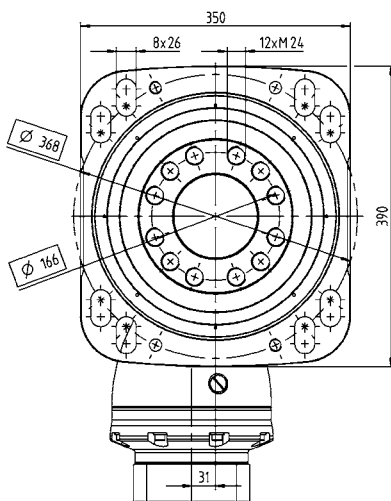



Compact and powerful
XPC⁺ and RPC⁺

bevel gearboxes



XPC+ / RPC+ – High precision and low ratios around the corner



XPC+

New performance standard, also available in the bevel version

Both the XP+ and RP+ Premium planetary gearboxes are now available in a right-angle version with bevel toothing. Bevel gearboxes are primarily characterized by low gear ratios (ratio 1 and 2) in the angle section. Consequently, right-angle and planetary gearbox combinations can achieve the same low ratios as planetary gearboxes. The product design has a positive influence on temperature development in the gearbox and reduces overall heat development in the system as a result. The overall system achieves a higher degree of positioning accuracy as a consequence.

XPC+ and RPC+ compared to industry standard

Product highlights

- Max. torsional backlash**
- XPC+ ≤ 4 arcmin (Standard)
- ≤ 2 arcmin (Reduced)
- RPC+ ≤ 1.3 arcmin
- XPC+ and RPC+:**
- Low ratios of $i = 4 - 88$ possible
- Optimized temperature distribution, even at high speeds
- High tilting moments and torsional rigidity
- Optimized for rack and pinion applications

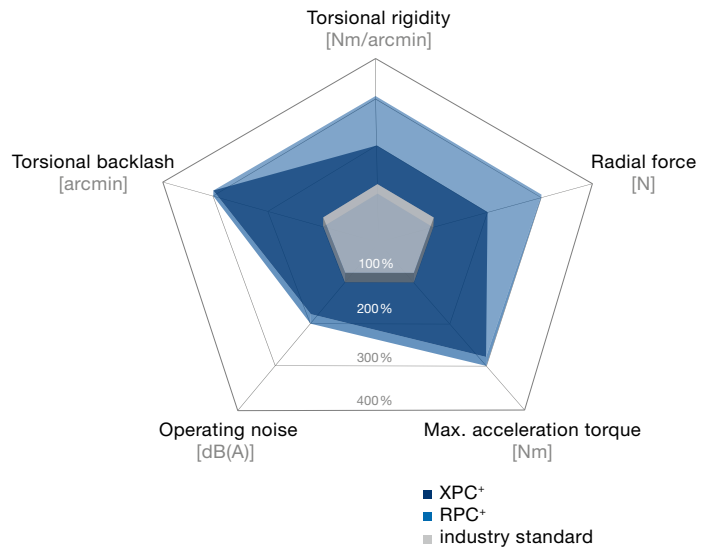

XPC+ with pinion and slots

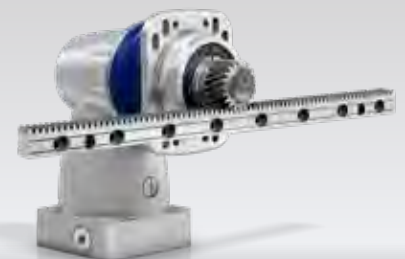

XPC+ with pinion, slots and rack

Specially designed output for transmitting extremely high torques

Intelligent design reduces losses to a minimum

High-quality bevel tooting with low gear ratios of $i = 1 - 2$ in the angle section

Low temperature development, even at high speeds



RPC+

Metal bellows coupling incorporated for thermal length compensation and protection of the motor bearing



RPC+ with pinion and slots



RPC+ with pinion, slots and rack

XPC+ 010 MF 2-stage

			2-stage
Ratio	i		4 / 5 / 7 / 8 / 10 / 14 / 20
Max. torque ^{a)}	T_{2a}	<i>Nm</i>	48 – 84
		<i>in.lb</i>	425 – 743
Max. acceleration torque (max. 1000 cycles per hour)	T_{2B}	<i>Nm</i>	40 – 70
		<i>in.lb</i>	354 – 620
Nominal torque (at n_n)	T_{2N}	<i>Nm</i>	27 – 28
		<i>in.lb</i>	239 – 248
Emergency stop torque (permitted 1000 times during the service life of the gearbox)	T_{2Not}	<i>Nm</i>	100 – 165
		<i>in.lb</i>	885 – 1460
Thermal speed limit (with 20°C ambient temperature and 10% torque utilization) ^{b)}	n_{IT}	<i>rpm</i>	3300 – 3750
Max. input speed	n_{1Max}	<i>rpm</i>	6000
Max. torsional backlash	j_t	<i>arcmin</i>	Standard ≤ 5 / Reduced ≤ 3
Torsional rigidity	C_{t21}	<i>Nm/arcmin</i>	3.1 – 5,5
		<i>in.lb/arcmin</i>	27 – 49
Max. tilting moment	M_{2KMax}	<i>Nm</i>	339
		<i>in.lb</i>	3000
Operating noise ^{c)}	L_{PA}	<i>dB(A)</i>	≤ 68
Lubrication			Lubricated for life
Clamping hub diameter		<i>mm</i>	14 – 19

^{a)} Application-specific design with cymex® – www.wittenstein-cymex.com

^{b)} For higher ambient temperatures, please reduce input speed

^{c)} At reference ratio and reference speed. Ratio-specific values available in cymex®.

2-stage

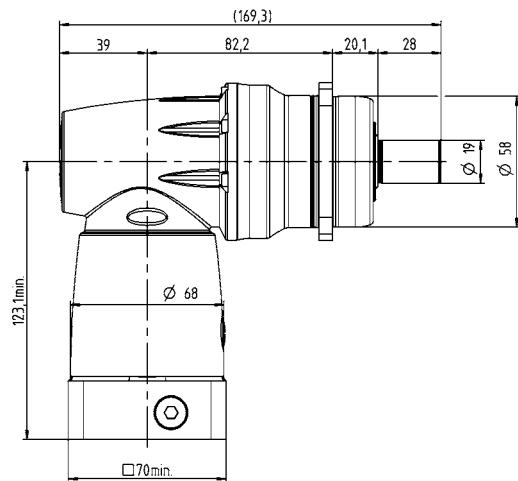
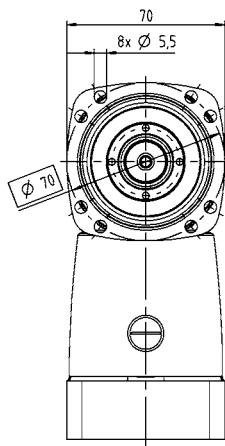

			2-stage
Ratio	i	4 / 5 / 7 / 8 / 10 / 14 / 20	
Max. torque ^{a)}	T_{2a}	<i>Nm</i>	144 – 240
		<i>in.lb</i>	1275 – 2124
Max. acceleration torque (max. 1000 cycles per hour)	T_{2B}	<i>Nm</i>	120 – 180
		<i>in.lb</i>	1062 – 1593
Nominal torque (at n_n)	T_{2N}	<i>Nm</i>	60 – 75
		<i>in.lb</i>	531 – 664
Emergency stop torque (permitted 1000 times during the service life of the gearbox)	T_{2Not}	<i>Nm</i>	192 – 418
		<i>in.lb</i>	1699 – 3700
Thermal speed limit (with 20°C ambient temperature and 10% torque utilization) ^{b)}	n_{TT}	<i>rpm</i>	2600 – 3050
Max. input speed	n_{1Max}	<i>rpm</i>	6000
Max. torsional backlash	j_t	<i>arcmin</i>	Standard ≤ 4 / Reduced ≤ 2
Torsional rigidity	C_{t21}	<i>Nm/arcmin</i>	9.1 – 14
		<i>in.lb/arcmin</i>	81 – 124
Max. tilting moment	M_{2KMax}	<i>Nm</i>	675
		<i>in.lb</i>	5974
Operating noise ^{c)}	L_{PA}	<i>dB(A)</i>	≤ 68
Lubrication			Lubricated for life
Clamping hub diameter		<i>mm</i>	19 – 28

^{a)} Application-specific design with cymex® – www.wittenstein-cymex.com

^{b)} For higher ambient temperatures, please reduce input speed

^{c)} At reference ratio and reference speed. Ratio-specific values available in cymex®.

2-stage

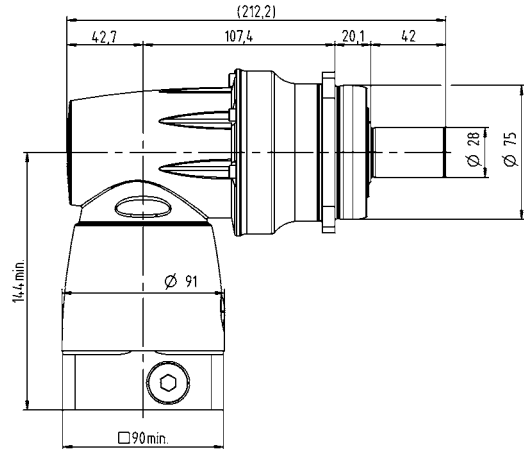
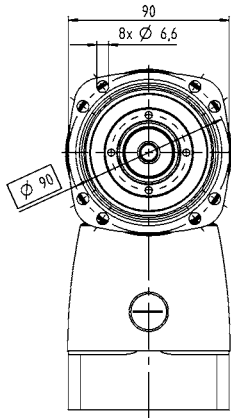

XPC+ 030 MF 2-stage

			2-stage
Ratio	i		4 / 5 / 7 / 8 / 10 / 14 / 20
Max. torque ^{a)}	T_{2a}	Nm	389 – 486
		$in.lb$	3443 – 4301
Max. acceleration torque (max. 1000 cycles per hour)	T_{2B}	Nm	320 – 420
		$in.lb$	2832 – 3717
Nominal torque (at n_n)	T_{2N}	Nm	120 – 180
		$in.lb$	1062 – 1593
Emergency stop torque (permitted 1000 times during the service life of the gearbox)	T_{2Not}	Nm	540 – 800
		$in.lb$	4779 – 7081
Thermal speed limit (with 20°C ambient temperature and 10% torque utilization) ^{b)}	n_{1T}	rpm	2100 – 2750
Max. input speed	n_{1Max}	rpm	4500
Max. torsional backlash	j_t	$arcmin$	Standard ≤ 4 / Reduced ≤ 2
Torsional rigidity	C_{t21}	$Nm/arcmin$	23 – 36
		$in.lb/arcmin$	204 – 319
Max. tilting moment	M_{2KMax}	Nm	1296
		$in.lb$	11471
Operating noise ^{c)}	L_{PA}	$dB(A)$	≤ 68
Lubrication			Lubricated for life
Clamping hub diameter		mm	28 – 38

^{a)} Application-specific design with cymex® – www.wittenstein-cymex.com

^{b)} For higher ambient temperatures, please reduce input speed

^{c)} At reference ratio and reference speed. Ratio-specific values available in cymex®.

2-stage

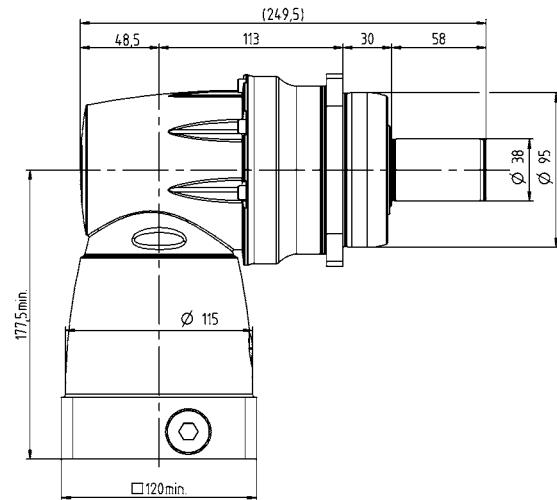
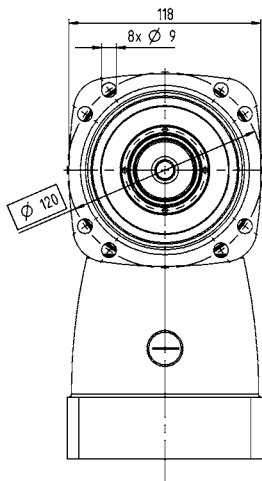

			2-stage
Ratio	i	4 / 5 / 7 / 8 / 10 / 14 / 20	
Max. torque ^{a)}	T_{2a}	<i>Nm</i>	792 – 1050
		<i>in.lb</i>	7010 – 9293
Max. acceleration torque (max. 1000 cycles per hour)	T_{2B}	<i>Nm</i>	700 – 875
		<i>in.lb</i>	6196 – 7744
Nominal torque (at n_n)	T_{2N}	<i>Nm</i>	240 – 370
		<i>in.lb</i>	2124 – 3275
Emergency stop torque (permitted 1000 times during the service life of the gearbox)	T_{2Not}	<i>Nm</i>	960 – 2170
		<i>in.lb</i>	8497 – 19206
Thermal speed limit (with 20°C ambient temperature and 10% torque utilization) ^{b)}	n_{TT}	<i>rpm</i>	1550 – 1900
Max. input speed	n_{1Max}	<i>rpm</i>	4500
Max. torsional backlash	j_t	<i>arcmin</i>	Standard ≤ 4 / Reduced ≤ 2
Torsional rigidity	C_{t21}	<i>Nm/arcmin</i>	50 – 74
		<i>in.lb/arcmin</i>	443 – 655
Max. tilting moment	M_{2KMax}	<i>Nm</i>	1635
		<i>in.lb</i>	14471
Operating noise ^{c)}	L_{PA}	<i>dB(A)</i>	≤ 70
Lubrication			Lubricated for life
Clamping hub diameter		<i>mm</i>	38

^{a)} Application-specific design with cymex® – www.wittenstein-cymex.com

^{b)} For higher ambient temperatures, please reduce input speed

^{c)} At reference ratio and reference speed. Ratio-specific values available in cymex®.

2-stage

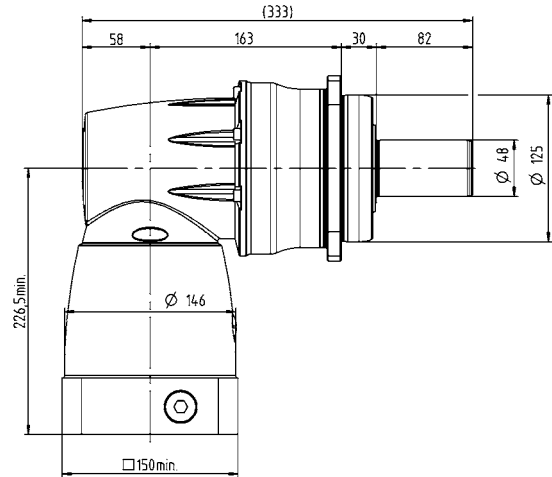
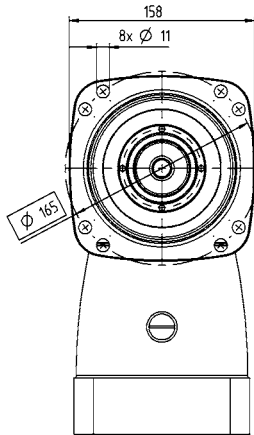

XPC+ 050 MF 2-stage

			2-stage
Ratio	i		4 / 5 / 7 / 8 / 10 / 14 / 20
Max. torque ^{a)}	T_{2a}	Nm	1512 – 2646
		$in.lb$	13382 – 23419
Max. acceleration torque (max. 1000 cycles per hour)	T_{2B}	Nm	1260 – 2205
		$in.lb$	11152 – 19516
Nominal torque (at n_n)	T_{2N}	Nm	700 – 750
		$in.lb$	6196 – 6638
Emergency stop torque (permitted 1000 times during the service life of the gearbox)	T_{2Not}	Nm	1560 – 4795
		$in.lb$	13807 – 42440
Thermal speed limit (with 20°C ambient temperature and 10% torque utilization) ^{b)}	n_{1T}	rpm	1050 – 1550
Max. input speed	n_{1Max}	rpm	4000
Max. torsional backlash	j_t	$arcmin$	Standard ≤ 4 / Reduced ≤ 2
Torsional rigidity	C_{t21}	$Nm/arcmin$	127 – 215
		$in.lb/arcmin$	1124 – 1903
Max. tilting moment	M_{2KMax}	Nm	3256
		$in.lb$	28818
Operating noise ^{c)}	L_{PA}	$dB(A)$	≤ 70
Lubrication			Lubricated for life
Clamping hub diameter		mm	48

^{a)} Application-specific design with cymex® – www.wittenstein-cymex.com

^{b)} For higher ambient temperatures, please reduce input speed

^{c)} At reference ratio and reference speed. Ratio-specific values available in cymex®.

2-stage

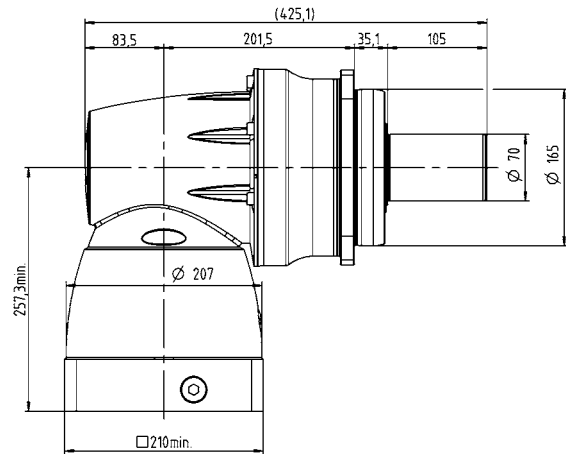
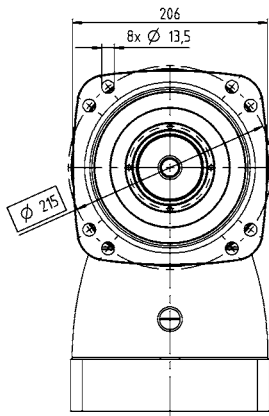

			3-stage
Ratio	i		22 / 27.5 / 38.5 / 44 / 55
Max. torque ^{a)}	T_{2a}	<i>Nm</i>	1402
		<i>in.lb</i>	12409
Max. acceleration torque (max. 1000 cycles per hour)	T_{2Not}	<i>Nm</i>	2613
		<i>in.lb</i>	23127
Nominal torque (at n_{2N})	T_{2B}	<i>Nm</i>	950
		<i>in.lb</i>	8408
Emergency stop torque (permitted 1000 times during the service life of the gearbox)	T_{2N}	<i>Nm</i>	675
		<i>in.lb</i>	5974
Thermal speed limit (with 20°C ambient temperature and 10% torque utilization) ^{b)}	n_{1T}	<i>rpm</i>	1800 – 2500
Max. input speed	n_{1Max}	<i>rpm</i>	4500
Max. torsional backlash	j_t	<i>arcmin</i>	Standard $\leq 1,3$
Torsional rigidity	C_{t21}	<i>Nm/arcmin</i>	194 – 215
		<i>in.lb/arcmin</i>	1717 – 1903
Max. tilting moment	M_{2KMax}	<i>Nm</i>	3600
		<i>in.lb</i>	31863
Operating noise ^{c)}	L_{PA}	<i>dB(A)</i>	≤ 70
Lubrication			Lubricated for life
Clamping hub diameter		<i>mm</i>	28 – 38

^{a)} Application-specific design with cymex® – www.wittenstein-cymex.com

^{b)} For higher ambient temperatures, please reduce input speed

^{c)} At reference ratio and reference speed. Ratio-specific values available in cymex®.

3-stage

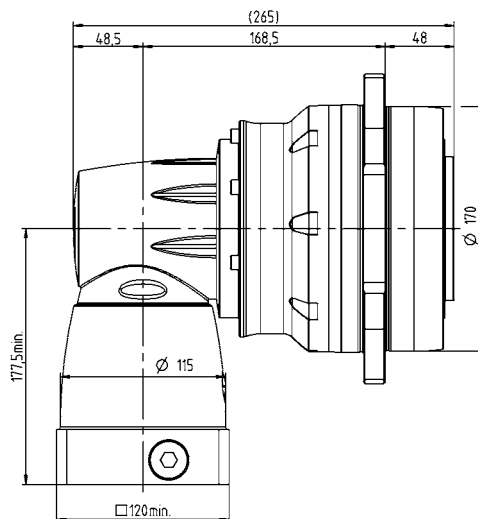
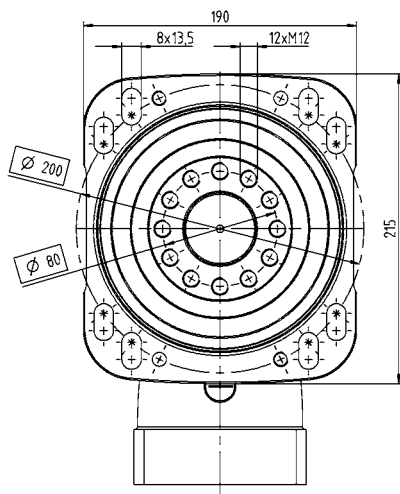

RPC+ 050 MA 3-stage

			3-stage
Ratio	i		22 / 27.5 / 38.5 / 44 / 55
Max. torque ^{a)}	T_{2a}	Nm	3822
		$in.lb$	33828
Max. acceleration torque (max. 1000 cycles per hour)	T_{2B}	Nm	3100
		$in.lb$	27437
Nominal torque (at n_n)	T_{2N}	Nm	1650
		$in.lb$	14604
Emergency stop torque (permitted 1000 times during the service life of the gearbox)	T_{2Not}	Nm	5280 – 7150
		$in.lb$	46732 – 63283
Thermal speed limit (with 20°C ambient temperature and 10% torque utilization) ^{b)}	n_{1T}	rpm	1300 – 1700
Max. input speed	n_{1Max}	rpm	4500
Max. torsional backlash	j_t	$arcmin$	Standard $\leq 1,3$
Torsional rigidity	C_{t21}	$Nm/arcmin$	607 – 671
		$in.lb/arcmin$	5372 – 5939
Max. tilting moment	M_{2KMax}	Nm	11000
		$in.lb$	97359
Operating noise ^{c)}	L_{PA}	$dB(A)$	≤ 71
Lubrication			Lubricated for life
Clamping hub diameter		mm	38

^{a)} Application-specific design with cymex® – www.wittenstein-cymex.com

^{b)} For higher ambient temperatures, please reduce input speed

^{c)} At reference ratio and reference speed. Ratio-specific values available in cymex®.

3-stage

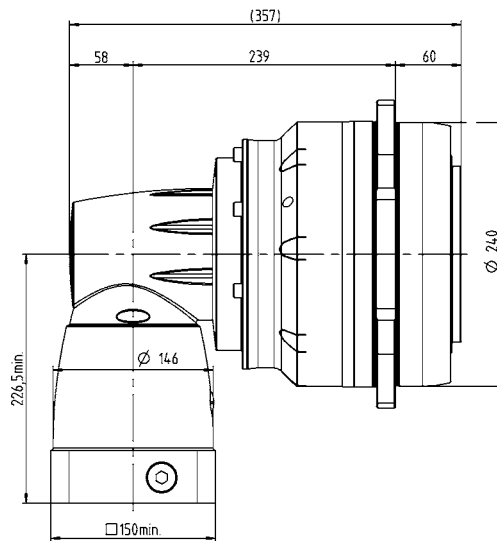
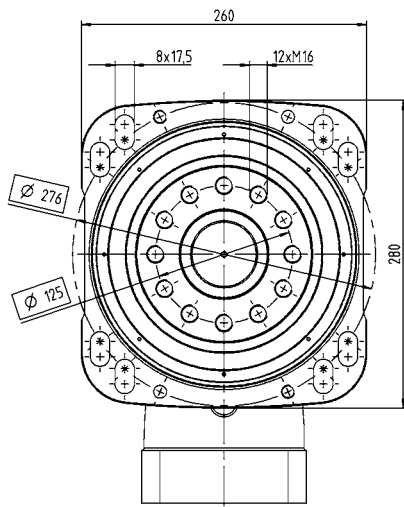

			3-stage
Ratio	i		22 / 27.5 / 38.5 / 44 / 55
Max. torque ^{a)}	T_{2a}	Nm	7535
		$in.lb$	66691
Max. acceleration torque (max. 1000 cycles per hour)	T_{2B}	Nm	5500
		$in.lb$	48679
Nominal torque (at n_n)	T_{2N}	Nm	3500
		$in.lb$	30978
Emergency stop torque (permitted 1000 times during the service life of the gearbox)	T_{2Not}	Nm	8580 – 14575
		$in.lb$	75940 – 129000
Thermal speed limit (with 20°C ambient temperature and 10% torque utilization) ^{b)}	n_{TT}	rpm	850 – 1350
Max. input speed	n_{rMax}	rpm	4000
Max. torsional backlash	j_t	$arcmin$	Standard $\leq 1,8$
Torsional rigidity	C_{t21}	$Nm/arcmin$	1039 – 1171
		$in.lb/arcmin$	9196 – 10364
Max. tilting moment	M_{2KMax}	Nm	21000
		$in.lb$	185867
Operating noise ^{c)}	L_{PA}	$dB(A)$	≤ 71
Lubrication			Lubricated for life
Clamping hub diameter		mm	48

^{a)} Application-specific design with cymex® – www.wittenstein-cymex.com

^{b)} For higher ambient temperatures, please reduce input speed

^{c)} At reference ratio and reference speed. Ratio-specific values available in cymex®.

3-stage

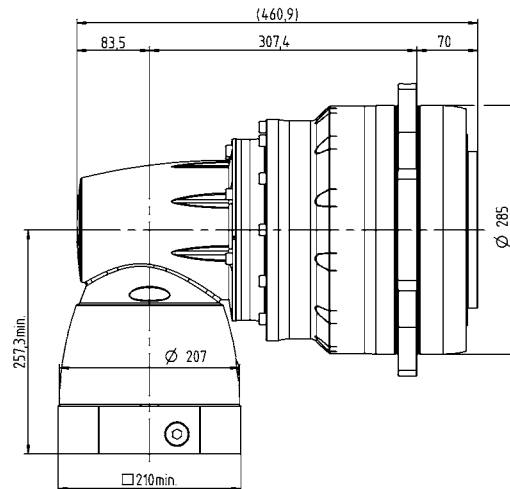
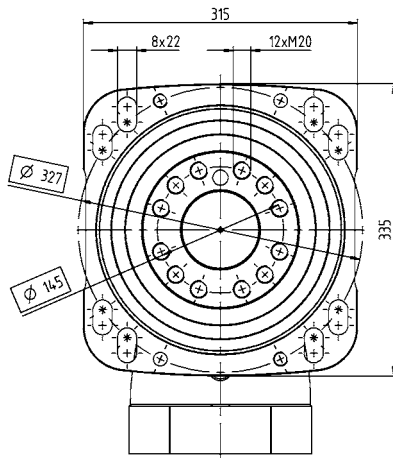

Basic Line gearbox overview



Product type		CP	CPS	CPK	CPSK	CVH	CVS
Version		MF	MF	MF	MF	MF / MT	MF / MT
Ratio ^{c)}	min. $i =$	3	3	3	3	7	7
	max. $i =$	100	100	100	100	40	40
Max. torsional backlash [arcmin] ^{c)}	Standard	≤ 12	≤ 12	≤ 13	≤ 15	≤ 15	≤ 15
	Reduced	–	–	–	–	–	–
Output type							
Smooth shaft		x	x	x	x	–	x
Shaft with key ^{d)}		x	x	x	x	–	x
Splined shaft (DIN 5480)		–	–	–	–	–	–
Blind hollow shaft		–	–	–	–	–	–
Hollow shaft interface		–	–	–	–	x	–
Keyed hollow shaft		–	–	–	–	x	–
Flanged hollow shaft		–	–	–	–	–	–
Flange		–	–	–	–	–	–
System output		–	–	–	–	–	–
Output on both sides		–	–	–	–	x	x
Input type							
Motor-mounted		x	x	x	x	x	x
Self-contained version ^{b)}		–	–	–	–	–	–
Characteristic							
Flange with slotted holes		–	–	–	–	–	–
ATEX ^{a)}		–	–	–	–	–	–
Food-grade lubrication ^{a) b)}		x	x	x	x	x	x
Corrosion resistant ^{a) b)}		–	–	–	–	–	–
Optimized mass inertia ^{a)}		–	–	–	–	–	–
System solutions							
Linear system (rack/pinion)		–	–	–	–	–	–
Servo actuator		–	–	–	–	–	–
Accessories (please refer to the product pages for further options)							
Coupling		x	x	x	x	–	x
Shrink disc		–	–	–	–	x	–

^{a)} Power reduction: technical data available on request

^{b)} Please contact WITTENSTEIN alpha

^{c)} In relation to reference sizes

^{d)} Power reduction: Please use our sizing software cymex® for a detailed sizing – www.wittenstein-cymex.com

Value Line gearbox overview



Product type		NP	NPL	NPS	NPT	NPR	NPK	NPLK	NPSK	NPTK	NPRK	NVH	NVS	HDV
Version		MF / MA	MF / MA	MF / MA	MF / MA	MF / MA	MF	MF	MF	MF	MF	MF	MF	MF / MT
Ratio ^{a)}	min. $i =$	3	3	3	3	3	3	3	3	3	3	4	4	4
	max. $i =$	100	100	100	100	100	100	100	100	100	100	400	400	400
Max. torsional backlash [arcmin] ^{a)}	Standard	≤ 8	≤ 8	≤ 8	≤ 8	≤ 8	≤ 11	≤ 11	≤ 11	≤ 11	≤ 11	≤ 6	≤ 6	≤ 10
	Reduced	-	-	-	-	-	-	-	-	-	-	-	-	-
Output type														
Smooth shaft		x	x	x	-	x	x	x	x	-	x	-	x	x
Shaft with key ^{d)}		x	x	x	-	x	x	x	x	-	x	-	x	x
Splined shaft (DIN 5480)		-	x	x	-	x	-	x	x	-	x	-	-	-
Blind hollow shaft		-	-	-	-	-	-	-	-	-	-	-	-	-
Hollow shaft interface		-	-	-	-	-	-	-	-	-	-	x	-	-
Keyed hollow shaft		-	-	-	-	-	-	-	-	-	-	x	-	-
Flanged hollow shaft		-	-	-	-	-	-	-	-	-	-	-	-	-
Flange		-	-	-	x	-	-	-	-	x	-	-	-	-
System output		-	-	-	-	-	-	-	-	-	-	-	-	-
Output on both sides		-	-	-	-	-	-	-	-	-	-	x	x	-
Input type														
Motor-mounted		x	x	x	x	x	x	x	x	x	x	x	x	x
Self-contained version ^{b)}		-	-	-	-	-	-	-	-	-	-	-	-	-
Characteristic														
Flange with slotted holes		-	-	-	-	x	-	-	-	-	x	-	-	-
ATEX ^{a)}		-	-	-	-	-	-	-	-	-	-	-	-	-
Food-grade lubrication ^{a) b)}		x	x	x	x	x	x	x	x	x	x	x	x	x
Corrosion resistant ^{a) b)}		-	-	-	-	-	-	-	-	-	-	x	x	x
Optimized mass inertia ^{a)}		-	-	-	-	-	-	-	-	-	-	-	-	-
System solutions														
Linear system (rack/pinion)		x	x	x	-	x	x	x	x	-	x	-	x	-
Servo actuator		-	-	-	-	-	-	-	-	-	-	-	-	x
Accessories (please refer to the product pages for further options)														
Coupling		x	x	x	-	x	x	x	x	-	x	-	x	-
Shrink disc		-	-	-	-	-	-	-	-	-	-	x	-	-

^{a)} Power reduction: technical data available on request

^{b)} Please contact WITTENSTEIN alpha

^{c)} In relation to reference sizes

^{d)} Power reduction: Please use our sizing software cymex® for a detailed sizing – www.wittenstein-cymex.com

Advanced Line gearbox overview



Product type		SP+	SP+ HIGH SPEED	SP+ HIGH SPEED friction optimized	TP+	TP+ HIGH TORQUE	HG+	SK+	SPK+
Version		MF	MC	MC-L	MF	MA	MF	MF	MF
Ratio ^{c)}	min. i =	3	3	3	4	22	3	3	12
	max. i =	100	100	10	100	302.5	100	100	10000
Max. torsional backlash [arcmin] ^{c)}	Standard	≤ 3	≤ 4	≤ 4	≤ 3	≤ 1	≤ 4	≤ 4	≤ 4
	Reduced	≤ 1	≤ 2	≤ 2	≤ 1	–	–	–	≤ 2
Output type									
Smooth shaft		x	x	x	–	–	–	x	x
Shaft with key ^{d)}		x	x	x	–	–	–	x	x
Splined shaft (DIN 5480)		x	x	x	–	–	–	x	x
Blind hollow shaft		x	x	x	–	–	–	–	x
Hollow shaft interface		–	–	–	–	–	x	–	–
Keyed hollow shaft		–	–	–	–	–	–	–	–
Flanged hollow shaft		–	–	–	–	–	–	–	–
Flange		–	–	–	x	x	–	–	–
System output		–	–	–	x	x	–	–	–
Output on both sides		–	–	–	–	–	x	x	x
Input type									
Motor-mounted		x	x	x	x	x	x	x	x
Self-contained version ^{b)}		x	–	–	x	–	–	–	–
Characteristic									
Flange with slotted holes		x	–	–	–	–	–	–	–
ATEX ^{a)}		x	x	–	–	–	x	x	–
Food-grade lubrication ^{a) b)}		x	x	x	x	x	x	x	x
Corrosion resistant ^{a) b)}		x	x	x	x	x	x	x	x
Optimized mass inertia ^{a)}		x	x	x	x	x	–	–	–
System solutions									
Linear system (rack/pinion)		x	x	–	x	x	–	x	x
Servo actuator		x	–	–	x	x	–	–	–
Accessories (please refer to the product pages for further options)									
Coupling		x	x	x	x	x	–	x	x
Shrink disc		x	x	x	–	–	x	–	x

^{a)} Power reduction: technical data available on request

^{b)} Please contact WITTENSTEIN alpha

^{c)} In relation to reference sizes

^{d)} Power reduction: Please use our sizing software cymex® for a detailed sizing – www.wittenstein-cymex.com



TK+	TPK+	TPK+ HIGH TORQUE	SC+	SPC+	TPC+	VH+	VS+	VT+	DP+	HDP+
MF	MF	MA	MF	MF	MF	MF	MF	MF	MF / MA	MA
3	12	66	1	4	4	4	4	4	16	22
100	10000	5500	2	20	20	400	400	400	55	55
≤ 4	≤ 4	≤ 1.3	≤ 4	≤ 4	≤ 4	≤ 3	≤ 3	≤ 3	≤ 3	≤ 1
-	≤ 2	-	-	≤ 2	≤ 2	≤ 2	≤ 2	≤ 2	≤ 1	-
-	-	-	x	x	-	-	x	-	-	-
-	-	-	x	x	-	-	x	-	-	-
-	-	-	-	x	-	-	x	-	-	-
-	-	-	-	x	-	-	-	-	-	-
-	-	-	-	-	-	x	-	-	-	-
-	-	-	-	-	-	x	-	-	-	-
x	-	-	-	-	-	-	-	x	-	-
-	x	x	-	-	x	-	-	-	x	x
-	x	x	-	-	x	-	-	-	-	-
x	x	x	-	-	-	x	x	-	-	-
x	x	x	-	-	-	x	x	-	-	-
x	x	x	x	x	x	x	x	x	x	x
x	x	x	x	x	x	x	x	x	x	x
-	-	-	-	-	-	-	-	-	x	x
x	x	x	x	x	x	-	x	x	-	-
-	-	-	-	-	-	-	-	-	-	-
x	x	x	x	x	x	-	x	x	-	-
-	-	-	-	x	-	x	-	-	-	-

Premium Line gearbox overview



Product type		XP+	RP+	XPK+	RPK+	XPC+	RPC+
Version		MF / MC	MF / MA	MF	MA	MF	MA
Catalog page		24	36	56	60	68	73
Ratio ^{c)}	min. $i =$	3	22	12	48	4	22
	max. $i =$	100	220	1000	5500	20	55
Max. torsional backlash [arcmin] ^{c)}	Standard	≤ 3	≤ 1	≤ 4	≤ 1.3	≤ 4	≤ 1.3
	Reduced	≤ 1	–	≤ 2	–	≤ 2	–
Output type							
Smooth shaft		x	–	x	–	x	–
Shaft with key ^{d)}		x	–	x	–	x	–
Splined shaft (DIN 5480)		x	–	x	–	x	–
Blind hollow shaft		x	–	x	–	x	–
Hollow shaft interface		–	–	–	–	–	–
Keyed hollow shaft		–	–	–	–	–	–
Flanged hollow shaft		–	–	–	–	–	–
Flange		–	x	–	x	–	x
System output		x	x	x	x	x	x
Output on both sides		–	–	–	–	–	–
Input type							
Motor-mounted		x	x	x	x	x	x
Self-contained version ^{b)}		x	–	–	–	–	–
Characteristic							
Flange with slotted holes		x	x	x	x	x	x
ATEX ^{a)}		–	–	–	–	–	–
Food-grade lubrication ^{a) b)}		x	x	x	x	x	x
Corrosion resistant ^{a) b)}		–	–	–	–	–	–
Optimized mass inertia ^{a)}		x	x	–	–	–	–
System solutions							
Linear system (rack/pinion)		x	x	x	x	x	x
Servo actuator		x	x	–	–	–	–
Accessories (please refer to the product pages for further options)							
Coupling		x	–	x	–	x	–
Shrink disc		x	–	x	–	x	–

^{a)} Power reduction: technical data available on request

^{b)} Please contact WITTENSTEIN alpha

^{c)} In relation to reference sizes

^{d)} Power reduction: Please use our sizing software cymex® for a detailed sizing – www.wittenstein-cymex.com

Servo actuator overview



Product type		PBG	PAG	PHG	RPM*	TPM+ DYNAMIC	TPM+ HIGH TORQUE	TPM+ POWER
Version		Standard	Standard	Standard	Customer specific	Standard	Standard	Standard
Ratio ^{d)}	min. $i =$	16	16	16	22	16	22	4
	max. $i =$	100	100	100	220	91	220	100
Max. torsional backlash ^{d)} [arcmin]	Standard	≤ 5	≤ 3	≤ 4	≤ 1	≤ 3	≤ 1	≤ 3
	Reduced	≤ 3	≤ 1	≤ 2	–	≤ 1	≤ 1	≤ 1
Output shape								
Smooth shaft		x	–	x	–	–	–	–
Shaft with key ^{d)}		x	–	x	–	–	–	–
Splined shaft (DIN 5480)		x	–	x	–	–	–	–
Blind hollow shaft		–	–	–	–	–	–	–
Hollow shaft interface		–	–	–	–	–	–	–
Keyed hollow shaft		–	–	–	–	–	–	–
Flanged hollow shaft		–	–	–	–	–	–	–
Flange		–	x	–	x	x	x	x
System output		–	x	x	x	x	x	x
Output on both sides		–	–	–	–	–	–	–
Input type								
Motor-mounted		–	–	–	–	–	–	–
Self-contained version		–	–	–	–	–	–	–
Characteristic								
Flange with slotted holes		–	–	x	x	–	–	–
ATEX ^{a)}		–	–	–	–	–	–	–
Food-grade lubrication ^{a) b)}		x	x	x	x	x	x	x
Corrosion resistant ^{a) b)}		–	–	–	–	x	x	x
Optimized mass Inertia ^{a)}		–	–	–	–	–	–	–
System solutions								
Linear system (rack / pinion)		x	x	x	x	x	x	x
Accessories (please refer to the product pages for further options)								
Coupling		x	x	–	–	x	x	x
Shrink disc		x	–	x	–	–	–	–
Power cable, signal cable, hybrid cable		x	x	x	x	x	x	x

^{a)} Power reduction: technical data available on request

^{b)} Please contact WITTENSTEIN alpha

^{c)} In relation to reference sizes

^{d)} Power reduction: Please use our sizing software cymex® for a detailed sizing – www.wittenstein-cymex.com

Overview of gearbox variants

XP **010** **S** - **M** **F** **1** - **5** - **0** **E** **1** - **2** **S**

Characteristic:

F = Food grade lubrication
G = Grease
H = Food-grade grease
K = Output SP+ compatible
R = Flange with slotted holes
S = Standard

Explanation of variants
deviating from the standard:

F = Food grade lubrication

These products are available with food-grade lubrication and can therefore be used in the food industry. Please note that the torque ratings in the catalog are reduced by 20 %.

G = Grease

This variant allows you to lubricate selected products with grease instead of oil. Please note that the torque ratings in the catalog are reduced by 20 %.

H = Food-grade grease

This variant allows you to lubricate selected products with food-safe grease instead of oil. Please note that the torque ratings in the catalog are reduced by 40 %.

K = Output SP+ compatible

The XP+ gearboxes are available with an SP+ output compatible housing (square). It is necessary to also choose the SP+ compatible output shaft in order to achieve full output compatibility. The technical data is similar to the SP+. Please contact WITTENSTEIN alpha for detailed information.

R = Flange with slotted holes

This output type is designed for linear applications with rack and pinion or belt pulley. Integrated slotted holes enable easy positioning of the pinion or simple tensioning of the belt.

R-flange with slots for XP+, XPK+ and XPC+ gearboxes

The R-flange has become indispensable in rack and pinion drive trains: it is the benchmark for modularity and ease of installation. That's why the R-flange is also used in our XP+ family as both a coaxial and a right-angle version, with a host of design options.

Benefits compared to the standard version:

- Easy mounting and positioning of the gearbox with a mounted pinion in relation to the rack
- Lower design costs
- Potential saving because no additional design elements are needed, e.g. intermediate plates
- More design freedom due to higher compactness



Premium Linear Systems with XP+ R

Views

XP+ 020 R

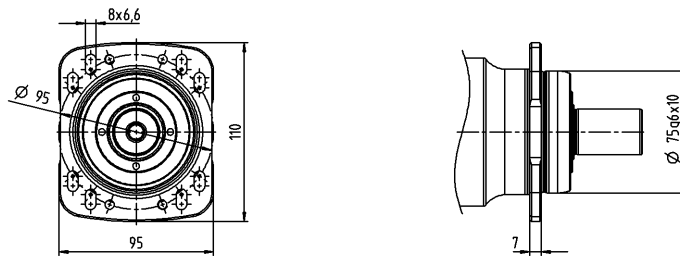

XP+ 030 R

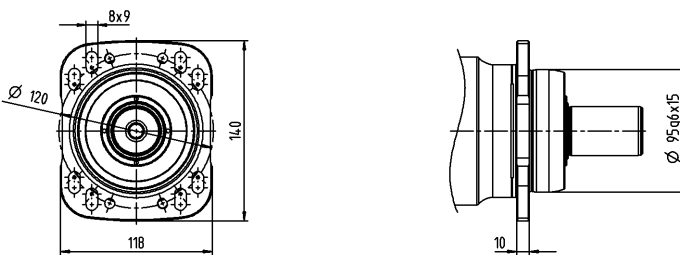

XP+ 040 R

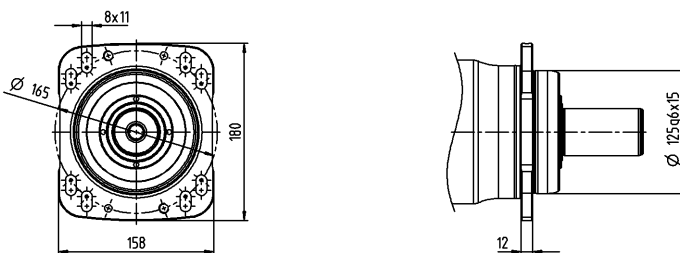

Special assembly washers for the slotted version are included in the scope of delivery.

alpha Premium Linear Systems

A new dimension in performance

With the Premium Linear System, the performance of the rack and pinion system enters a new dimension. While others are still busy adapting existing solutions, WITTENSTEIN alpha has stayed several steps ahead by developing the new linear systems. The innovative Premium Linear System is used in all applications where the individual requirements far exceed what has previously been possible. Compared to the industry standard, the values have been improved by 150 % on average.

The alpha preferential linear system – The best from each segment

Our preferential linear systems in the premium segment are always comprised of the perfect combination of gearbox, pinion, rack and lubrication system. The systems have been optimized to achieve the required feed force, feed speed, stiffness and degree of utilization of the individual components.



For further information, refer to our alpha Linear Systems catalog and our website:
www.wittenstein-alpha.com/linear-systems

For a wide range of applications

Linear systems from WITTENSTEIN alpha are suitable for a wide range of applications and industries. New standards and advantages have been achieved in the following areas:

- Smooth operation
- Positioning accuracy
- Feed force
- Power density
- Rigidity
- Easy installation
- Design options
- Scalability

Together with a comprehensive range of services, we pledge to support you from the initial concept to the design, installation and commissioning phase. We will also ensure a consistent supply of spare parts.

Your benefits at a glance

Perfectly matched components

Maximum efficiency and power density

Exceptional linear system rigidity for even greater dynamics and precision

Simple mounting and maximum integration in the drive train

Available in different sizes, power categories and segments

Consultation and quality – everything from a single source!



INIRA®: The revolution in rack assembly



Simply scan the QR code using your smartphone to see INIRA® in action.

INIRA® combines our existing innovative concepts for the simple, safe and efficient installation of racks. INIRA® clamping, INIRA® adjusting and INIRA® pinning have already made the assembly process much faster, more accurate and more ergonomic. Available for the Advanced and Premium Linear Systems.

INIRA® clamping: Simply faster and more ergonomic
Previously, enormous effort was required to clamp racks to the machine bed using screw clamps. INIRA® clamping integrates the clamping device in the rack. The rack incorporates a mounting sleeve which is guided over the head of the fastening screw to ensure quick and ergonomic clamping.

INIRA® pinning: Simply better and more efficient
The previous method used for pinning racks was extremely time-consuming. Precision bores have to be drilled and the chips generated must be carefully removed from the assembly. INIRA® pinning now offers a completely new solution for the chipless pinning of racks, which reduces installation times considerably (time spent on each rack ~ 1 min).

INIRA® adjusting: Simply safer and more precise
In combination with INIRA® clamping, INIRA® adjusting is the ideal solution for perfectly adjusting the transition between two rack segments. The innovative setting tool can adjust the transition extremely reliably and precisely, accurate to the micrometer.



INIRA® clamping



INIRA® adjusting



INIRA® pinning

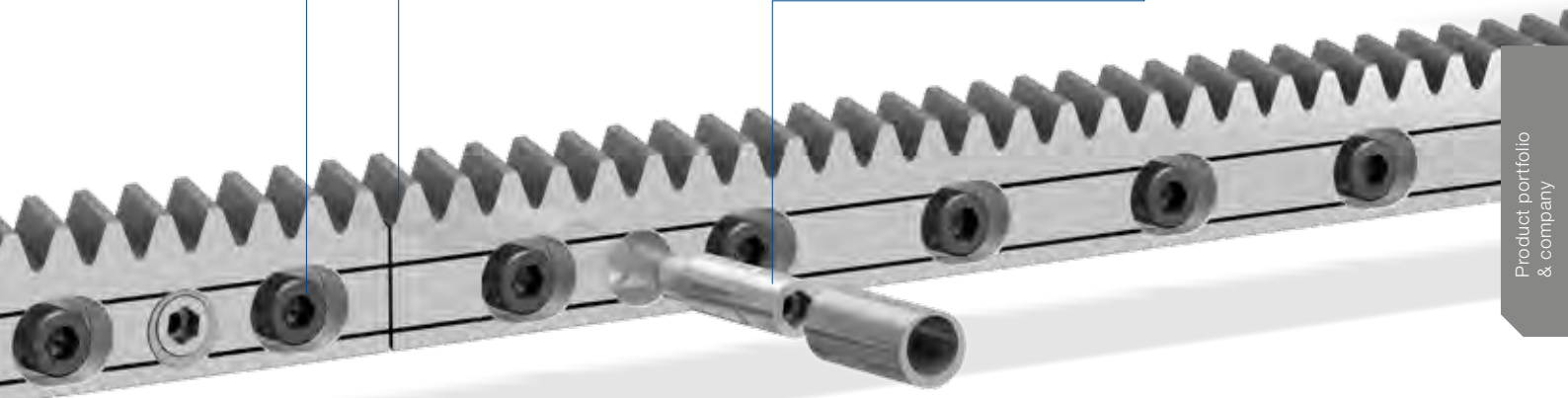

Precision meets motion = premo® by WITTENSTEIN alpha

premo® is a powerful servo actuator platform that combines absolute precision with perfect movement. The central idea behind this first fully scalable servo actuator platform is uncompromising flexibility from the viewpoint of the user. Motors and gearboxes with application-related graduated performance characteristics can be configured modularly to individual servo actuators. The result is a

highly versatile modular system with customizable power, designed for a wide variety of applications. The core of the servo actuator is a torsionally rigid precision gearbox with low backlash and excellent torque density combined with the equally powerful, permanent magnet servo motor with a split winding that guarantees low cogging and minimal velocity ripple.

premo® – clearly superior in performance

- Higher machine performance thanks to higher acceleration torque
- High torque density combined with a compact design allow for the realization of higher performance machines with significant space saving
- Improved connectivity to next generation controllers from leading system providers through the use of digital feedback (EnDat 2.2, DSL, HIPERFACE DSL®, DRIVE-CLiQ)
- Compatibility for high bus voltages up to 750 V DC
- Reduced wiring requirement through single-connector technology
- Improved reliability and safety through the use of more powerful brakes and SIL 2 encoders

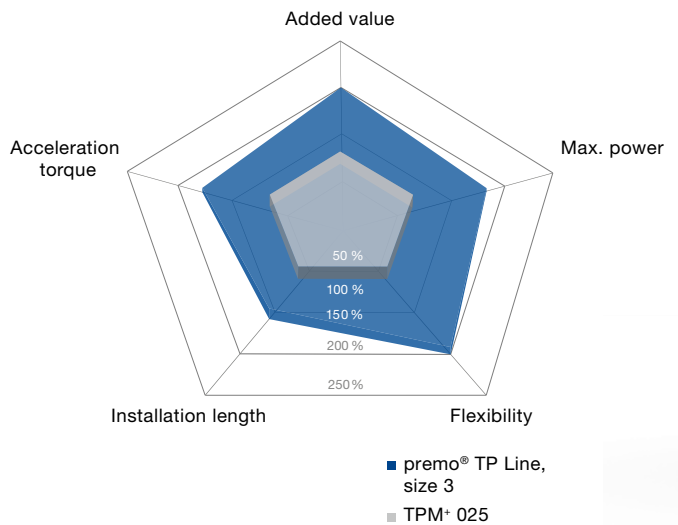

Product highlights

- Optimized power density for greater energy efficiency and productivity
- Flexible mechanical and electrical interfaces for high scalability
- Variety of options for individually upgrading the basic configuration

premo® application examples



Handling portal
premo® SP Line

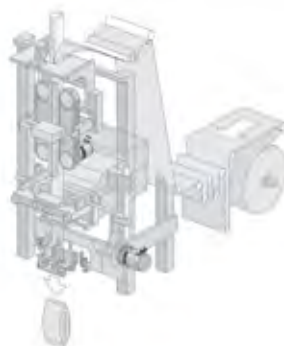

Fill and Seal machine
premo® TP Line



Milling cutter for a machining center
premo® XP Line

Typical fields of application and industry solutions

- Delta robot (axes 1–3, swivel axis)
- Handling portal (Z-axis, swivel/rotating axis)
- Machine tool reaming (rotating axes A–C, tool changer)
- Fill and Seal Machine (incl. jaw stroke, sealing jaw, blade)
- Folding carton packaging (incl. assembly/folding, filling valve)
- Plastic thermoform (tool axis)

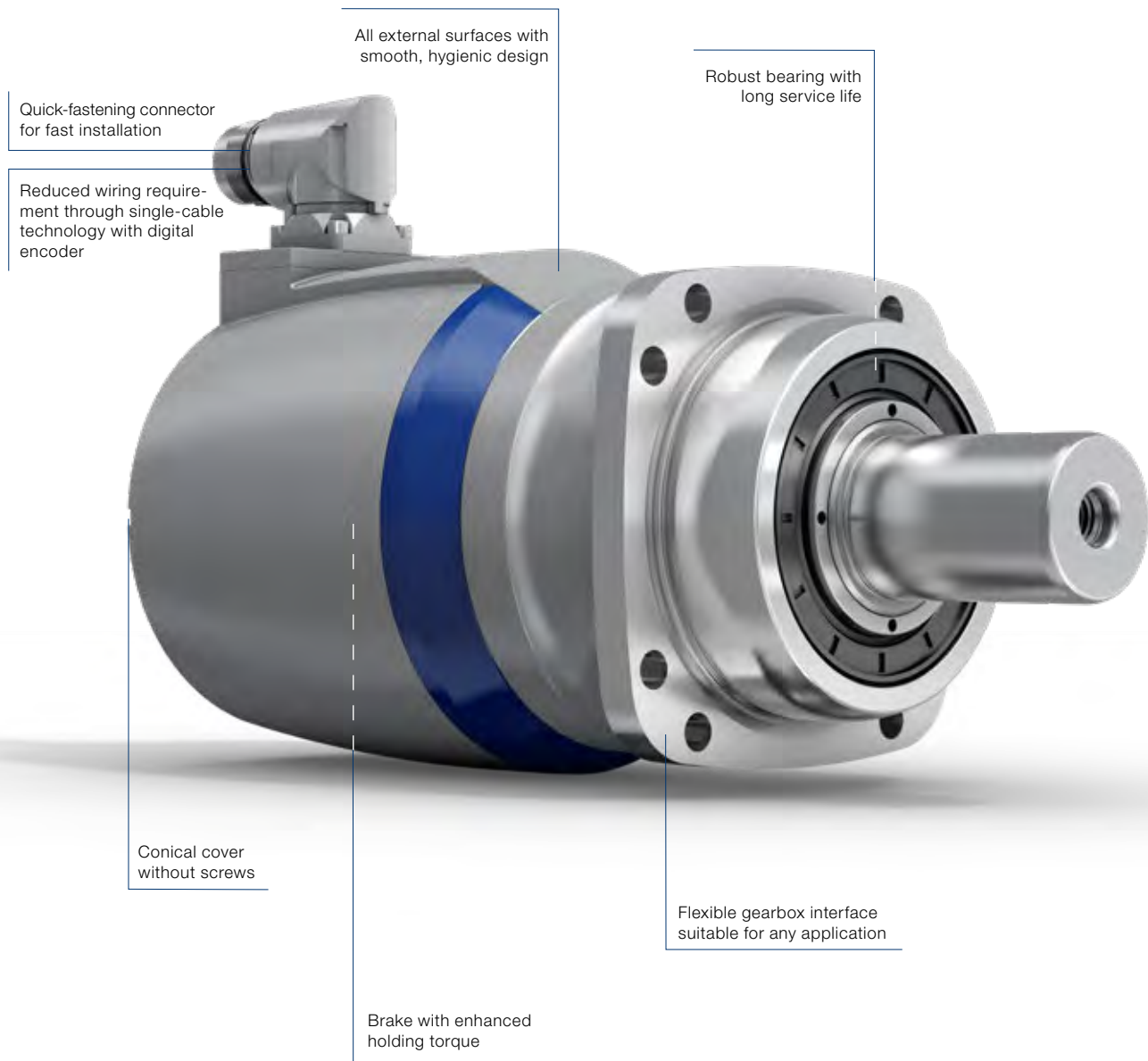

Galaxie® drive system – Performance in a new dimension



Next Technology Drive

This award-winning innovation by WITTENSTEIN surpasses all previous drives in terms of torsional backlash, torque density, stiffness and compactness. The innovative core of the Galaxie® is that the drive makes almost full surface contact during power transmission, which produces a defined torque density as well as exceptional torsional rigidity and zero backlash – even at the zero crossing.

Product highlights

Our advantage and your benefit:

- High torsional rigidity
- No backlash – even at the zero crossing
- Hydrodynamic surface contact
- Maximum torque density
- High robustness
- Hollow shaft

Schematic diagram

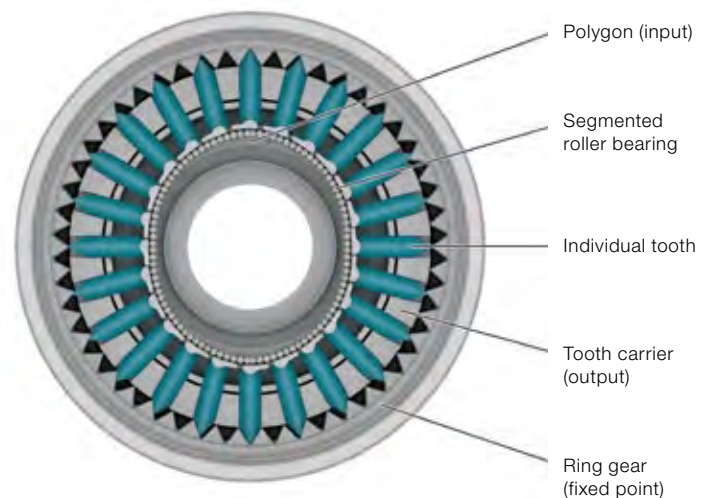

Complete system under one roof

Options:

- Integrated holding brake
- Different feedback systems
- Additional encoder system at the input



Find out more about the Galaxie® by simply scanning the QR code using your smartphone.

Extremely compact

Optimized mass moments of inertia

Integrated water cooling

Max. torsional rigidity

Synchronous servo motor

Galaxie® gearbox

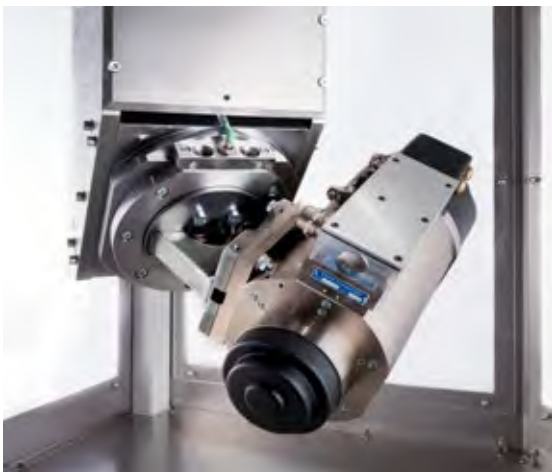
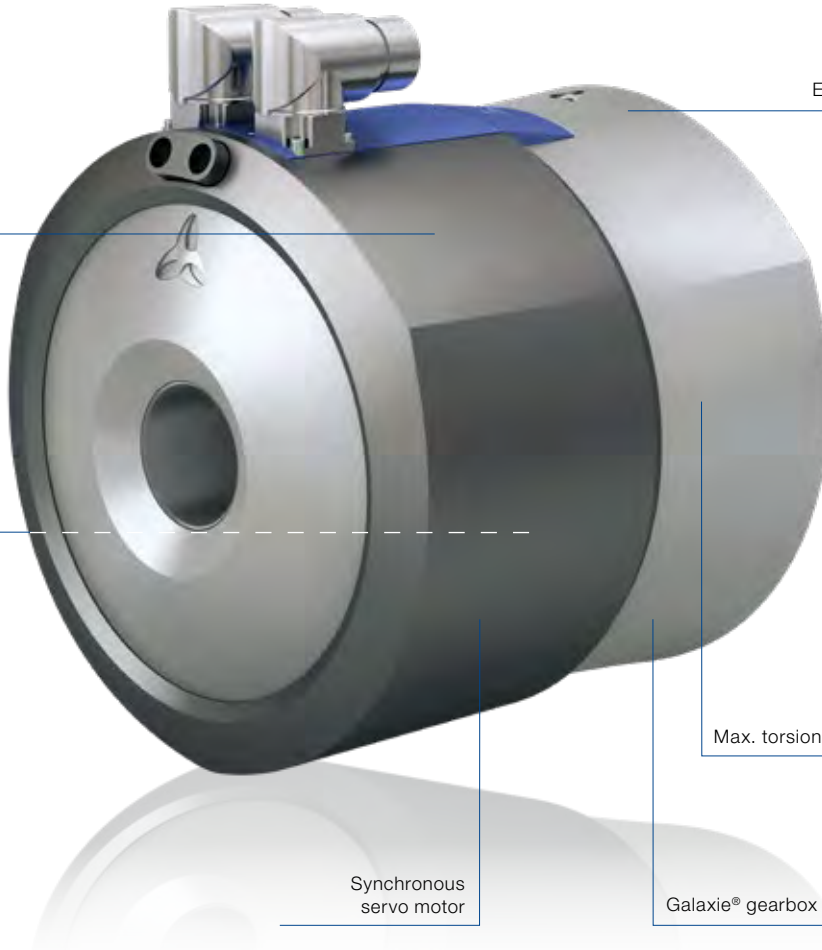

Galaxie® mounted on a milling cutter manufactured by Maka Systems GmbH for processing carbon composite materials – High Speed for maximum component quality



Galaxie® in a spline rolling machine – faster processing speeds increase productivity by 40 %

Accessories – smart additions for intelligent performance

Gearboxes, accessories and consulting from a single source

Optimization of your added value chain

Use the combination of gearbox and accessories in a complete package to streamline your internal processes.

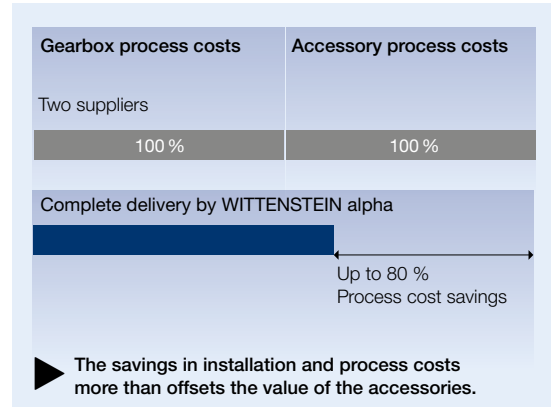
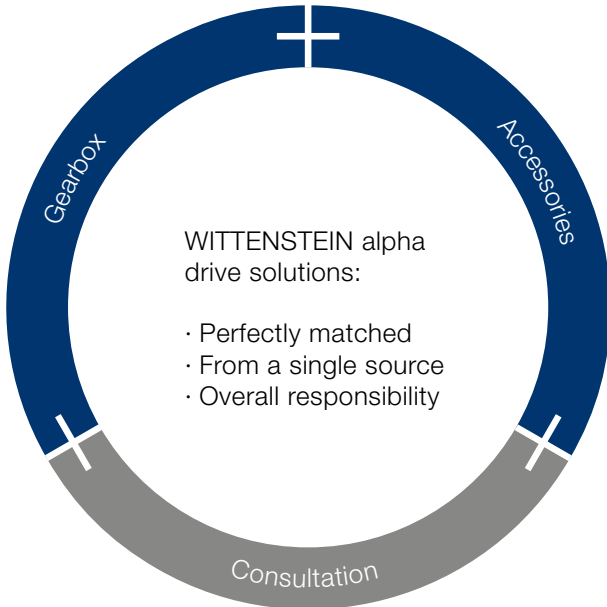

Shrink disks

Shrink disks are frictional hub / shaft connections. Together with our hollow shaft or mounted shaft gearboxes for mounting directly on load shafts, machines can be designed to take up a minimal installation space.

The benefits:

- Simple mounting and removal
- Quick selection, easy and convenient
- Optional: corrosion resistant version



Preferred shrink disk series

To view a wide range of nickel-plated, stainless steel and other shrink disks as well as all the relevant technical data and dimensions, visit our homepage

www.wittenstein-alpha.com



Couplings

Couplings are used for compensating misalignment during assembly and material-related heat expansion

Compensation for shaft misalignment

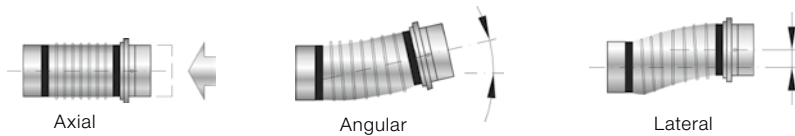

Metal bellows coupling

- Compensation for shaft misalignment
- Completely backlash free
- Corrosion resistant version available as an option (BC2, BC3, BCT)
- High torsional rigidity



Elastomer coupling

- Compensation for shaft misalignment
- Completely backlash free
- Selectable torsional rigidity/damping
- Compact design
- Extremely simple installation (plug-in)



Torque limiter

- Compensation for shaft misalignment
- Completely backlash free
- Precise, preset overload protection (switch-off in 1 – 3 ms)
- Precise repeat accuracy
- Just one protection element per axis

Preferred coupling series

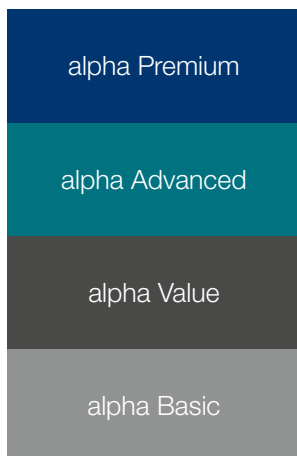

Preferred series are defined for the relevant gearbox segments to make selection easier. Preferred couplings are defined based on the maximum torque that the gearbox can transmit. Standard industrial conditions for the number of cycles (1000/h) and ambient temperature were adopted.

Please note that the coupling load is based on the torque that the gearbox can transmit and not the torque in your application. We recommend using our cymex®5 design software to create a more detailed design. (www.wittenstein-cymex.com)

ELC For more coupling types, please visit www.wittenstein-alpha.com

Support at each interaction stage

With the WITTENSTEIN alpha service concept, we are also setting new standards in the field of customer support.

Global presence

Our global consultation network will help you overcome your complex challenges through our extensive experience, a variety of design tools and individual engineering services.

Speed counts

Our speedline® team guarantees fast response times in the area of logistics. We provide on-site support during the installation and commissioning of mechanical systems to give you a sustained competitive edge.

Personal consultation

Our highly qualified and committed expert personnel will accompany you throughout the entire product lifecycle - around the clock. When it comes to customer support, you can count on us!

Design

Consultation
CAD POINT
SIZING ASSISTANT
Sizing software cymex®
Engineering

Installation

speedline® delivery
Installation on-site
Operating & installation instructions
Pick-up & return service



We are happy to advise you:

24 h service hotline: +49 7931 493-12900

No matter where you need us:

A comprehensive sales and service network provides quick availability and competent support worldwide.



Maintenance

- 24 h service hotline
- Maintenance and inspection
- Repair
- cymex® statistics
- Modernization

Training

- Product training
- Sizing training
- Installation training
- Service training

Support at each interaction stage

Design

Whatever your requirements are: we offer the right design methodology. Use the CAD POINT to gain easy access to CAD files, the SIZING ASSISTANT for creating simple

designs, cymex® 5 for precise dimensioning and our engineering service for individual solutions.

Consultation

- Personal contact on-site
- Professional application calculations and drive design create the best solutions

Engineering

Catalog gearboxes:

- Advanced software tools for accurate calculation, simulation and analysis of the drive train
- Optimization of your productivity and reduction in development costs

Special gearboxes:

- Gearing design and development
- Development and production of special gearboxes
- Send all inquiries to: sondergetriebe@wittenstein.de



CAD POINT

- 3D data of selected solution
- Online comparison with motor geometry
- Transparent and simple selection of required components



SIZING ASSISTANT

- Efficient online design within seconds
- Convenient comparison function
- Automatic geometry adjustment



cymex® 5 sizing software

- Dimensioning, design and evaluation of the entire drive train
- Reliable, efficient design
- Optimization of drive system



Installation

All delivered products are perfectly matched to your application environment and fully operational right away.

Our service experts support you in the installation and commissioning of complex mechatronic systems, guaranteeing maximum availability of your plant.

speedline® delivery

Tel. +49 7931 493-10444

- Delivery of standard series in 24 or 48 hours ex works*
- Outstanding flexibility for fast deliveries at short notice

Operating and installation instructions

- Detailed explanations of how to use the product
- Motor installation videos
- Assembly videos on rack and pinion system

Installation on-site

- Professional installation
- Optimal integration of the system in your application
- Explanation of the drive function

Pick-up and return service

- Cost savings through minimization of downtimes
- Professional logistics organization
- Reduction of transport risks through customized, direct pick-up and delivery



* Non-binding delivery time depending on part availability.

Support at each interaction stage

Maintenance

WITTENSTEIN alpha guarantees fast repairs of the highest quality and precision – with short throughput times and intensive support. In addition, we will provide you with information about various measurements, material

analyses and condition monitoring inspections. You can rely on short response times, unbureaucratic processing and individual support.

24 h service hotline

Tel. +49 7931 493-12900

- Available round the clock
- Personal, prompt service for resolving time-critical maintenance issues

cymex® statistics

- Systematic field data acquisition
- Reliability calculations (MTBF)
- Customized evaluations

Maintenance and inspection

- Documentation regarding condition and expected service life
- Maintaining required state
- Customized maintenance schedules

Modernization

- Professional retrofitting
- Reliable compatibility testing of existing solutions

Repair

- Restoring to required state
- Short throughput times
- Immediate response in time-critical situations



Training

Discover how our products function and how they can add value to your application. We offer you training courses at our premises or on-site at your plant. Benefit from

practice-oriented learning methods and a highly skilled team of trainers.

Product training

Greater knowledge enables greater achievement. We will be pleased to share our expert knowledge with you: Profit from our many years of experience and learn more about the product portfolio of WITTENSTEIN alpha.

Sizing training

Become a design expert! We will provide you with training courses on our design software, adapted to your requirements. Whether for beginners or experts, for occasional or regular users – we adapt our training course to your wishes and requirements.

Installation training

We offer you individual training courses on-site for your system application of selected linear axes as well as professional installation.

Service training

Participation in a service training course is a prerequisite for sourcing spare parts at the parts list level. We offer you training courses at our premises or on-site at your plant. Moreover, we regularly host maintenance workshops at which the participants are instructed in safe handling during mounting of the motor to the gearbox as well as the independent replacement of wearing parts and gearbox assemblies.



The WITTENSTEIN group – The company and its fields of business



WITTENSTEIN

With approximately 2,900 employees worldwide, WITTENSTEIN SE stands for innovation, precision and excellence in the world of mechatronic drive technology, both nationally and internationally. The group is active in six innovative fields of business. Furthermore, WITTENSTEIN SE is represented by some 60 subsidiaries in around 40 countries in all important technology and sales markets worldwide.



Our fields of expertise

We provide know-how for a host of different sectors:

- Machine and plant construction
- Software development
- Aerospace
- Automotive & E-mobility
- Energy
- Oil & Gas Exploration and Production
- Medical technology
- Measurement and testing technology
- Nanotechnology
- Simulation

The WITTENSTEIN Group



WITTENSTEIN alpha GmbH
High-precision servo drives and linear systems



WITTENSTEIN cyber motor GmbH
Highly dynamic servo motors and drive electronics



WITTENSTEIN galaxie GmbH
Superior gearboxes and drive systems

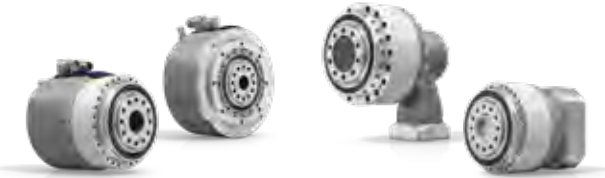

WITTENSTEIN motion control GmbH
Customized linear and rotary servo systems



WITTENSTEIN aerospace & simulation GmbH
Mechatronic drive systems for aerospace & simulation



attocube systems AG
Nanoprecision drive and measurement technology solutions



baramundi software AG
Secure management of IT infrastructure in offices and production areas



alpha Premium Line – Gearbox design

We recommend using **cymex® 5 sizing software** to dimension the complete drive train in detail.



cymex® 5
– Calculate on the Best

- Detailed calculation of complete drive trains
- Precise simulation of motion and load variables
- Downloadable software for complex designs

www.wittenstein-cymex.com



Operating mode:

In order to assess the application in detail, a distinction must be made between two operating modes.

1. Cyclic operation S5:

- Number of cycles ≤ 1000 /hour
- Duty cycle $< 60\%$ and < 20 minutes

Recommended gearbox model: MF / MA version

2. Continuous operation S1:

- Duty cycle $\geq 60\%$ or ≥ 20 minutes

Recommended gearbox model: MC version

Max. torque $T_{2\alpha}$:

$T_{2\alpha}$ represents the maximum torque transmitted by the gearbox. Once the number of cycles and the shock factor have been determined, the maximum acceleration torque can be calculated at the output ($T_{2b, fs}$). The maximum torque $T_{2\alpha}$ must be reduced in line with the relevant output shaft revolutions (f_a).

The calculated torque $T_{2b, fs}$ must not exceed the maximum torque $T_{2\alpha}$ of the gearboxes.

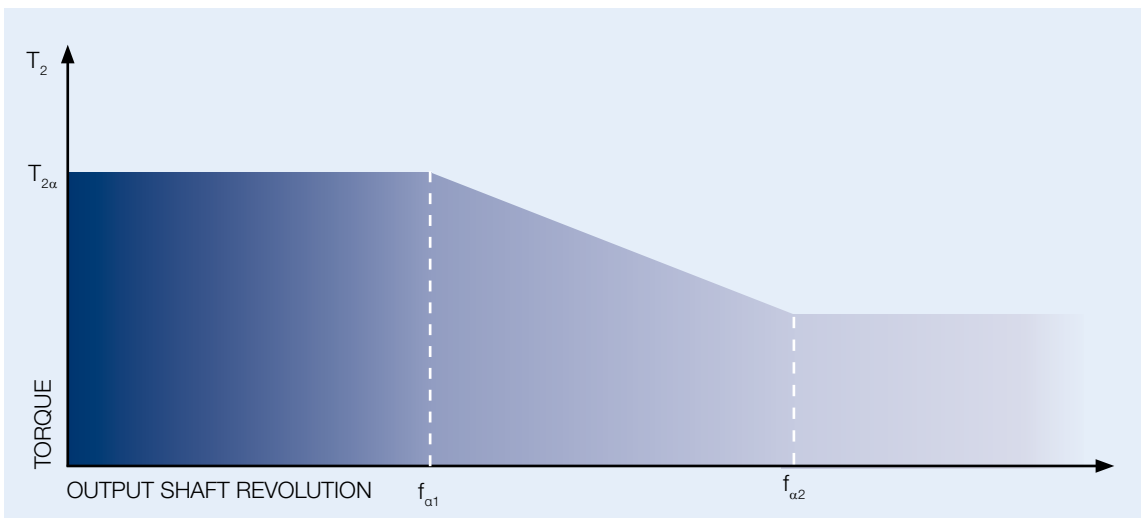

Torque in line with the relevant output shaft revolution

Max. tilting torque M_{2kmax} :

The maximum tilting moment M_{2kmax} can be calculated using the following formula:

$$M_{2kmax} = \frac{F_{2aMax} \cdot l_{Fa} + F_{2qMax} \cdot (l_{Fq} + Z_2)^a}{W^b}$$

- a) l_{Fa} , l_{Fq} , Z_2 in mm
 b) $W = 1000$ (metric)

Example with output shaft and flange:

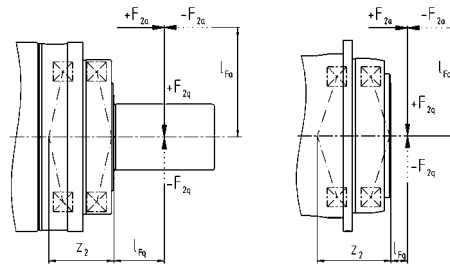

One prerequisite of the calculation is that the axial force is applied centrally and does not exceed 37 % in relation to the radial force.

XP*		010	020	030	040	050
Z_2	[mm]	75.3	91.5	115	101.2	128.4
	[in]	2.96	3.60	4.53	3.98	5.06

RP*		030	040	050	060	080
Z_2	[mm]	93.5	106.1	141.9	181.9	195.6
	[in]	3.68	4.18	5.59	7.16	7.70

Drive options:



Clamping hub with socket (standard)



Optimized mass inertia clamping hub –
For highly dynamic applications



Clamping hub with keyed socket –
the form fit connection for even the
highest safety requirements

Glossary – the **alphabet**

Adapter plate

WITTENSTEIN alpha uses a system of standardized adapter plates to connect the motor and the gearbox, making it possible to mount a WITTENSTEIN alpha gearbox to any desired motor without difficulty.

Angular minute

A degree is subdivided into 60 angular minutes (= 60 arcmin = 60').

Example:

If the torsional backlash is $j_t = 1$ arcmin, the output can be turned $1/60^\circ$. The repercussions for the application are determined by the arc length:
 $b = 2 \cdot \pi \cdot r \cdot \alpha^\circ / 360^\circ$.

Example:

A pinion with a radius $r = 50$ mm mounted on a gearbox with torsional backlash $j_t = 3$ arcmin can be turned $b = 0.04$ mm.

Axial force (F_{2AMax})

The axial force acting on a gearbox runs parallel to its output shaft or perpendicular to its output shaft. It may be applied with axial offset via a lever arm y_2 under certain circumstances, in which case it also generates a bending moment. If the axial force exceeds the permissible catalog values (max. axial force F_{2AMax}), additional design features (e.g. axial bearings) must be implemented to absorb these forces.

Example with output shaft and flange:

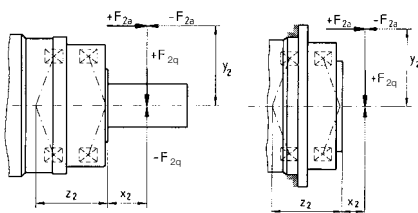

Bushing

If the motor shaft diameter is smaller than the → **clamping hub**, a bushing is used to compensate the difference in diameter. The bushing must have a minimum thickness of 1 mm and a motor shaft diameter of 2 mm.

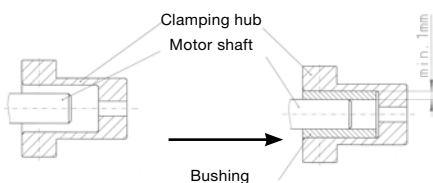

CAD POINT

Performance data, dimension sheets and CAD data for all types of gearbox can be found online in our CAD POINT together with comprehensive documentation of the selection.
 (www.wittenstein-cad-point.com)

Clamping hub

The clamping hub ensures a frictional connection between the motor shaft and gearbox. A → **bushing** is used as the connecting element if the motor shaft diameter is smaller than that of the clamping hub. Optionally, a positive connection via a parallel key is also possible.

Continuous operation (S1)

Continuous operation is defined by the → **duty cycle**. If the duty cycle is greater than 60 % and / or longer than 20 minutes, this qualifies as continuous operation. → **Operating modes**

Cyclic operation (S5)

Cyclic operation is defined via the → **duty cycle**. If the duty cycle is less than 60 % and shorter than 20 minutes, it qualifies as cyclic operation (→ **operating modes**).

cymex®

cymex® is the calculation software developed by our company for dimensioning complete drive trains. The software enables the precise simulation of motion and load variables. The software is available for download from our website (www.wittenstein-cymex.com). We can also provide training to enable you to make full use of all the possibilities provided by the software.

Degree of protection (IP)

The various degrees of protection are defined in DIN EN 60529 "Degrees of protection offered by enclosure (IP code)". The IP degree of protection (International Protection) is represented by two digits. The first digit indicates the protection against the ingress of impurities and the second the protection against the ingress of water.

Example:

IP65

Protection against the ingress of dust (dust-proof)

Protection against spray water

Duty cycle (DC)

The cycle determines the duty cycle DC. The times for acceleration (t_b), constant travel if applicable (t_c) and deceleration (t_d) combined yield the duty cycle in minutes. The duty cycle is expressed as a percentage with inclusion of the pause time t_e .

$$DC [\%] = \frac{t_b + t_c + t_d}{t_b + t_c + t_d + t_e} \cdot 100 \quad \frac{\text{Motion duration}}{\text{Cycle duration}}$$

$$DC [\text{min}] = t_b + t_c + t_d$$

Emergency stop torque (T_{2Not})

The Emergency stop torque T_{2Not} is the maximum permissible torque at the gearbox output and must not be reached more than 1000 times during the life of the gearbox. It must never be exceeded!

Efficiency (η)

Efficiency [%] η is the ratio of output power to input power. Power lost through friction reduces efficiency to less than 1 or 100 %.

$$\eta = P_{\text{off}} / P_{\text{on}} = (P_{\text{on}} - P_{\text{loss}}) / P_{\text{on}}$$

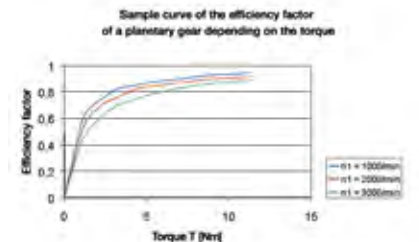

WITTENSTEIN alpha always measures the efficiency of a gearbox during operation at full load. If the input power or torque are lower, the efficiency rating is also lower due to the constant no-load torque. Power losses do not increase as a result. A lower efficiency is also expected at high speeds (see illustration).



Ex symbol

Devices bearing the Ex symbol comply with EU Directive 94 / 9 / EC (ATEX) and are approved for use in defined explosion-hazardous zones.

Detailed information on explosion groups and categories, as well as further information on the relevant gearbox are available upon request.

HIGH SPEED (MC)

The HIGH SPEED version of our gearbox has been specially developed for applications in continuous operation at high input speeds, e.g. as found in the printing and packaging industries.

HIGH TORQUE (MA)

WITTENSTEIN alpha gearboxes are also available in a HIGH TORQUE version. These gearboxes are particularly suited to applications requiring extremely high torques and maximum stiffness.

Hysteresis curve

The hysteresis is measured to determine the torsional rigidity of a gearbox. The result of this measurement is known as the hysteresis curve.

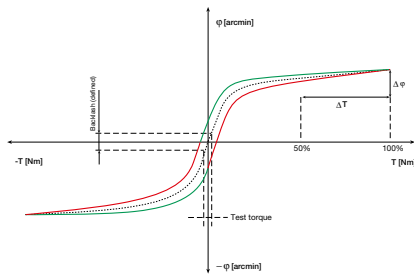

If the input shaft is locked, the gearbox is continuously loaded and relieved at the output in both directions up to a defined torque. The torsional angle is plotted against the torque. This yields a closed curve from which the → **torsional backlash** and → **torsional rigidity** can be calculated.

Jerk (j)

Jerk is derived from acceleration and is defined as the change in acceleration within a unit of time. The term impact is used if the acceleration curve changes abruptly and the jerk is infinitely large.

Lateral force ($F_{2QM\max}$)

The max. lateral force $F_{2QM\max}$ [N] is the force component acting at right angles to the output shaft or parallel to the output flange. It acts perpendicular to the → axial force and can assume an axial distance of x_2 in relation to the shaft nut or shaft flange, which acts as a lever arm. The lateral force produces a bending moment (see also → axial force).

Mass inertia ratio ($\lambda = \text{Lambda}$)

The mass inertia ratio λ is the ratio of external inertia (application side) to internal inertia (motor and gearbox side). It is an important parameter determining the controllability of an application. Accurate control of dynamic processes becomes more difficult with differing mass moments of inertia and as λ becomes greater. WITTENSTEIN alpha recommends that a guideline value of $\lambda < 5$ is maintained. A gearbox reduces the external mass moment of inertia by a factor of $1/i^2$.

$$\lambda = \frac{J_{\text{extern}}}{J_{\text{intern}}}$$

J reduced externally at input:

$$J'_{\text{external}} = J_{\text{external}} / i^2$$

Simple applications ≤ 10

Dynamic applications ≤ 5

Highly dynamic applications ≤ 1

Mass moment of inertia (J)

The mass moment of inertia J [kg/cm²] is a measurement of the effort applied by an object to maintain its momentary condition (at rest or moving).

Mesh frequency (f_z)

The mesh frequency may cause problems regarding vibrations in an application, especially if the excitation frequency corresponds to an intrinsic frequency of the application. The mesh frequency can be calculated for planetary gearboxes from WITTENSTEIN alpha (exception: gearboxes with ratio $i = 8$) using the formula $f_z = 1.8 \cdot n_2$ [rpm] and on planetary gearboxes from WITTENSTEIN alpha, is independent of the ratio. If it does indeed become problematic, the intrinsic frequency of the system can be changed or another gearbox (e.g. hypoid gearbox) with a different mesh frequency can be selected.

No-load running torque (T_{012})

The no-load running torque T_{012} is the torque which must be applied to a gearbox in order to overcome the internal friction; it is therefore considered lost torque. The values specified in the catalog are calculated by WITTENSTEIN alpha at a speed of $n_1 = 3000$ rpm and an ambient temperature of 20 °C.

T_{012} :	0	1 → 2
	without load	from input side towards output side

Idling torques decrease during operation.

NSF

Lubricants certified as grade H1 by the NSF (National Sanitation Foundation) can be used in the food sector where occasional unavoidable contact with food cannot be excluded.

Operating modes

(continuous operation **S1** and cyclic operation **S5**)

Gearboxes are selected depending on whether the motion profile is characterized by frequent acceleration and deceleration phases in → **cyclic operation** (S5) as well as pauses, or whether it is designed for → **continuous operation** (S1), i.e. with long phases of constant motion.

Operating noise (L_{PA})

The gear ratio and speed affect the noise level. As a general rule: A higher speed means a higher noise level, while a higher ratio means a lower noise level. The values specified in our catalog are based on a reference ratio and speed. The reference speed is either $n_1 = 3000$ rpm or $n_1 = 2000$ rpm depending on the size of the gearbox. You can find ratio-specific values in cymex® – www.wittenstein-cymex.com.

Output shaft revolution (f_a)

Factor f_a determines the number of life time cycles for the required gearbox service life. It describes the number of revolutions at the output used to assess the torque permitted at the output.

→ Refer to this term for further details.

Glossary – the **alphabet**

Positioning accuracy

The positioning accuracy is determined by the angular deviation from a setpoint and equals the sum of the torsional angles due to load → **(torsional rigidity and torsional backlash)** and kinetics → **(synchronization error) occurring simultaneously in practise** .

Quality control

All Premium and Advanced gearboxes are subject to a final inspection before they leave the WITTENSTEIN alpha factory to ensure that they are all delivered within specification.

Ratio (i)

The gear ratio i indicates the factor by which the gearbox transforms the three relevant parameters of motion (speed, torque and mass moment of inertia). The factor is a result of the geometry of the gearing elements (Example: $i = 10$).

$$\begin{array}{ccc}
 n_1 = 3000 \text{ min}^{-1} & \begin{array}{c} :i \\ \cdot i \end{array} & \begin{array}{c} T_2 = 200 \text{ Nm} \\ n_2 = 300 \text{ min}^{-1} \end{array} \\
 T_1 = 20 \text{ Nm} & & \\
 J_1 = 0,10 \text{ kgm}^2 & & J_2 = 10 \text{ kgm}^2 \\
 & & \text{(Application)}
 \end{array}$$

Safety note

For applications with special safety requirements (e.g. vertical axes, clamped drives), we recommend exclusive use of our Premium and Advanced products (excluding V-Drive).

SIZING ASSISTANT

The online SIZING ASSISTANT from WITTENSTEIN alpha allows the efficient selection of a gearbox in seconds. You can use various motor or application entry options to select the right gearbox for your application in seconds (www.sizing-assistant.com).

Speed (n)

Two speeds are of relevance when dimensioning a gearbox: the maximum speed and the thermal speed limit at the input. The maximum permissible speed n_{1Max} must not be exceeded because it serves as the basis for dimensioning → **cyclic operation**. The nominal speed n_{1N} must not be exceeded in → **continuous operation**. The thermal speed limit n_{1T} at an ambient temperature of 20° C, is determined by the maximum

gearbox temperature of $T = 90^\circ \text{ C}$ at no-load. As can be seen in the diagram below, the temperature limit is reached more quickly in the presence of an elevated outside temperature. In other words: the nominal input speed must be reduced if the ambient temperature is high.

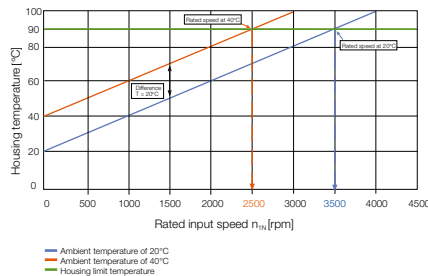

Delivery of speedline®

If necessary, you can receive delivery of standard series in 24 or 48 hours ex works. Outstanding flexibility for fast deliveries at short notice

Synchronization

Synchronization refers to the measurable speed variation between the input and output during one revolution of the output shaft. It is caused by manufacturing tolerances and causes minute angular deviations and ratio fluctuations.

Technical data

You can download further technical data relating to the entire product portfolio from our website

Tilting rigidity

The tilting rigidity C_{2K} [Nm/arcmin] of the gearbox consists of the bending stiffness of the output or pinion shaft and the stiffness of the output bearing. It is defined as the quotient of tilting moment M_{2K} [Nm] and tilting angle Φ [arcmin] ($C_{2K} = M_{2K} / \Phi$).

Tilting torque (M_{2K})

The tilting torque M_{2K} is a result of the → **axial and lateral forces** applied and their respective points of application in relation to the inner radial bearing on the output side.

Torsional backlash (j_t)

Torsional backlash j_t [arcmin] is the maximum angle of torsion of the output shaft in relation to the input. Simply put, the torsional backlash represents the gap between two tooth flanks.

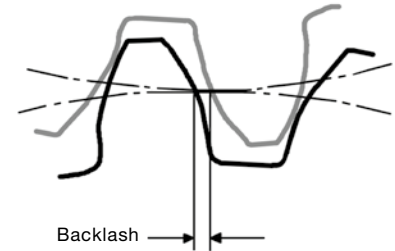

Torsional backlash is measured with the input shaft locked.

The output is then loaded with a defined test torque in order to overcome the internal gearbox friction. The main factor affecting torsional backlash is the face clearance between the gear teeth. The low torsional backlash of WITTENSTEIN alpha gearboxes is due to their high manufacturing accuracy and the specific combination of gear wheels.

Torsional rigidity (C_{t21})

Torsional rigidity [Nm/arcmin] C_{t21} is defined as the quotient of applied torque and resulting torsion angle ($C_{t21} = \Delta T / \Delta \Phi$). It shows the torque required to turn the output shaft by one angular minute. The torsional rigidity can be determined from the → **hysteresis curve**.

Torsional rigidity C , angle of torsion Φ

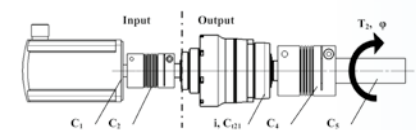

Reduce all torsional rigidity values at the output:

$$C_{(n),out} = C_{(n),in} * i^2$$

with i = Gearbox ratio [-]

$C_{(n)}$ = Individual rigidity values [Nm/arcmin]

Note: The torsional rigidity C_{t21} for the gearbox always relates to the output.

Series connection of torsional rigidity values

$$1/C_{\text{tot}} = 1/C_{1,\text{out}} + 1/C_{2,\text{out}} + \dots + 1/C_{(n)}$$

Angle of torsion ϕ [arcmin]

$$\phi = T_2 * 1/C_{\text{tot}}$$

with T_2 = output torque [Nm]

Torque (M)

The torque is the actual driving force of a rotary motion. The force and lever arm combine to produce the torque that acts around the axis of rotation. $M = F \cdot l$

Torque ($T_{2\alpha}$)

$T_{2\alpha}$ represents the maximum torque transmitted by the gearbox. This value may decrease depending on the application-specific conditions and the precise evaluation of the movement profile.



→ Refer to this term for further details.

Glossary – Formulae

Formulae

Torque [Nm]	$T = J \cdot \alpha$	J = Mass moment of inertia [kgm ²] α = Angular acceleration [1/s ²]
Torque [Nm]	$T = F \cdot l$	F = Force [N] l = Lever, length [m]
Acceleration force [N]	$F_b = m \cdot a$	m = Mass [kg] a = Linear acceleration [m/s ²]
Frictional force [N]	$F_{\text{Reib}} = m \cdot g \cdot \mu$	g = Acceleration due to gravity 9.81 m/s ² μ = Coefficient of friction
Angular speed [1/s]	$\omega = 2 \cdot \pi \cdot n / 60$	n = Speed [rpm] π = PI = 3.14...
Linear speed [m/s]	$v = \omega \cdot r$	r = Radius [m]
Linear speed [m/s] (spindle)	$v_{\text{sp}} = \omega \cdot h / (2 \cdot \pi)$	h = Screw pitch [m]
Linear acceleration [m/s²]	$a = v / t_b$	t_b = Acceleration time [s]
Angular acceleration [1/s²]	$\alpha = \omega / t_b$	
Pinion path [mm]	$s = m_n \cdot z \cdot \pi / \cos \beta$	m_n = Normal module [mm] z = Number of teeth [-] β = Helix angle [°]

Conversion table

1 mm	= 0.039 in
1 Nm	= 8.85 in.lb
1 kgcm²	= 8.85 x 10 ⁻⁴ in.lb.s ²
1 N	= 0.225 lb _f
1 kg	= 2.21 lb _m

Symbol

Symbol	Unit	Designation
C	Nm/arcmin	Stiffness
ED	%, min	Duty cycle
F	N	Force
f_s	–	Load factor
f_e	–	Factor for duty cycle
i	–	Ratio
j	arcmin	Backlash
J	kgm ²	Mass moment of inertia
$K1$	Nm	Factor for bearing calculation
L	h	Service life
L_{PA}	dB(A)	Operating noise
m	kg	Mass
M	Nm	Torque
n	rpm	Speed
p	–	Exponent for bearing calculation
η	%	Efficiency
t	s	Time
T	Nm	Torque
v	m/min	Linear speed
z	1/h	Number of cycles

Index

Index	Designation
Capital letter	Permissible values
Small letter	Actual values
1	Input
2	Output
A/a	Axial
B/b	Acceleration
c	Constant
d	Deceleration
e	Pause
h	Hours
K/k	Tilting
m	Mean
Max/max	Maximum
Mot	Motor
N	Nominal
Not/not	Emergency stop
0	No load
Q/q	Lateral
t	Torsional
T	Tangential

XP+ / RP+ – Ordering code

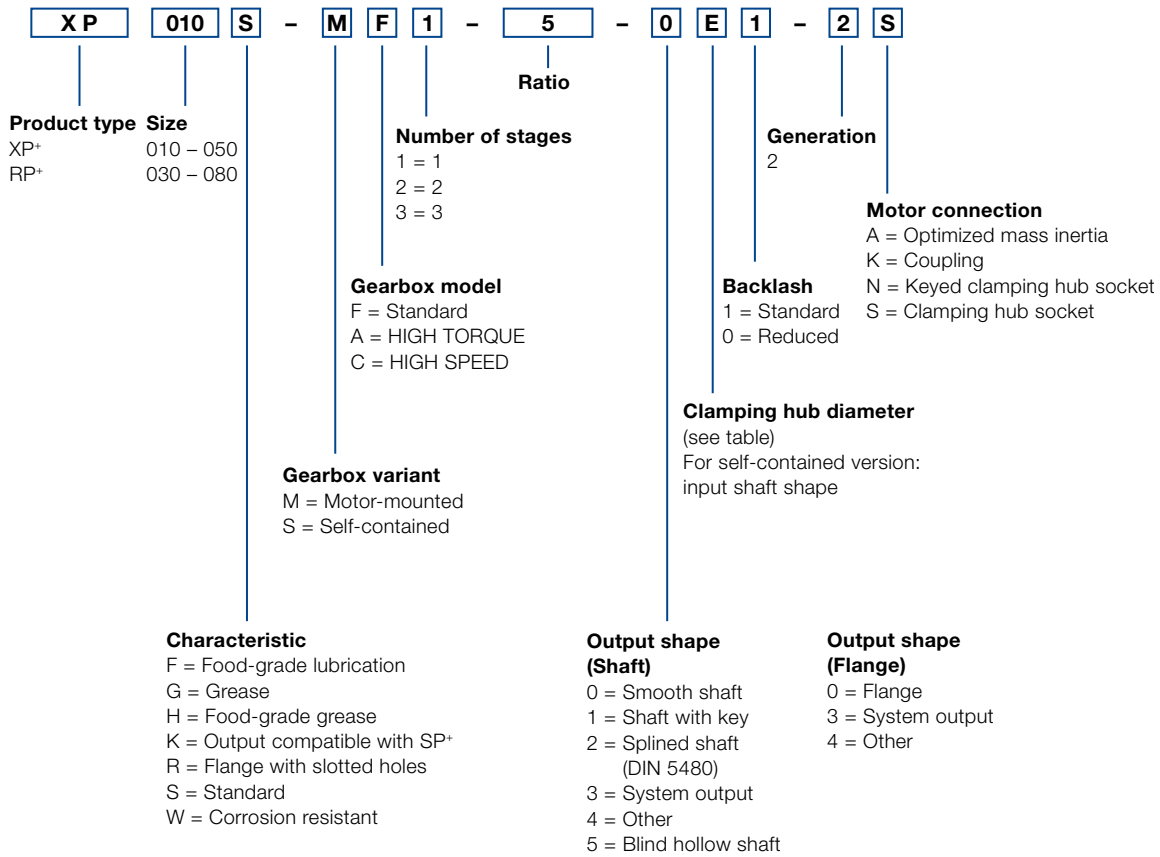

XPK+ / RPK+ – Ordering code

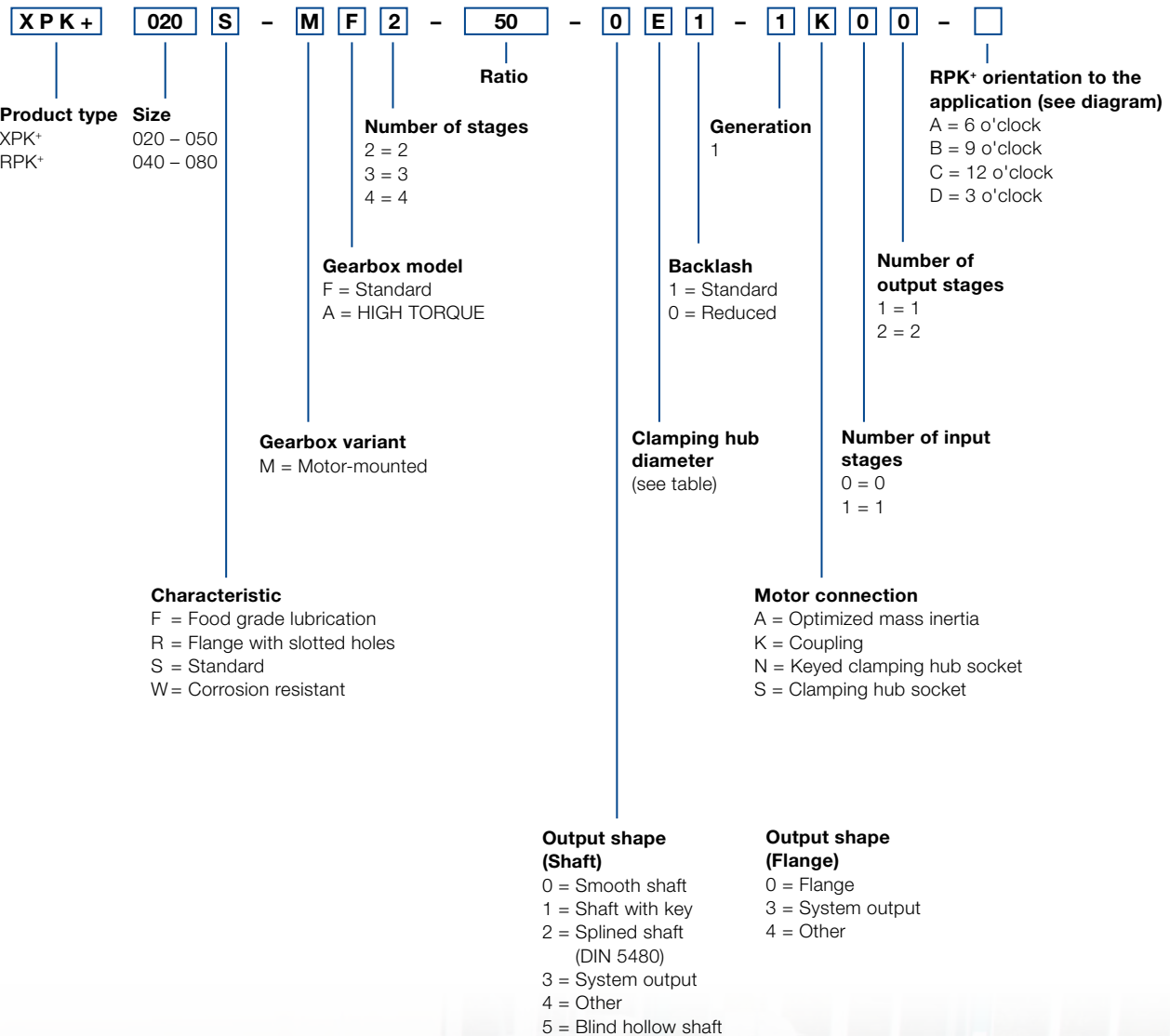

XPC+ / RPC+ – Ordering code

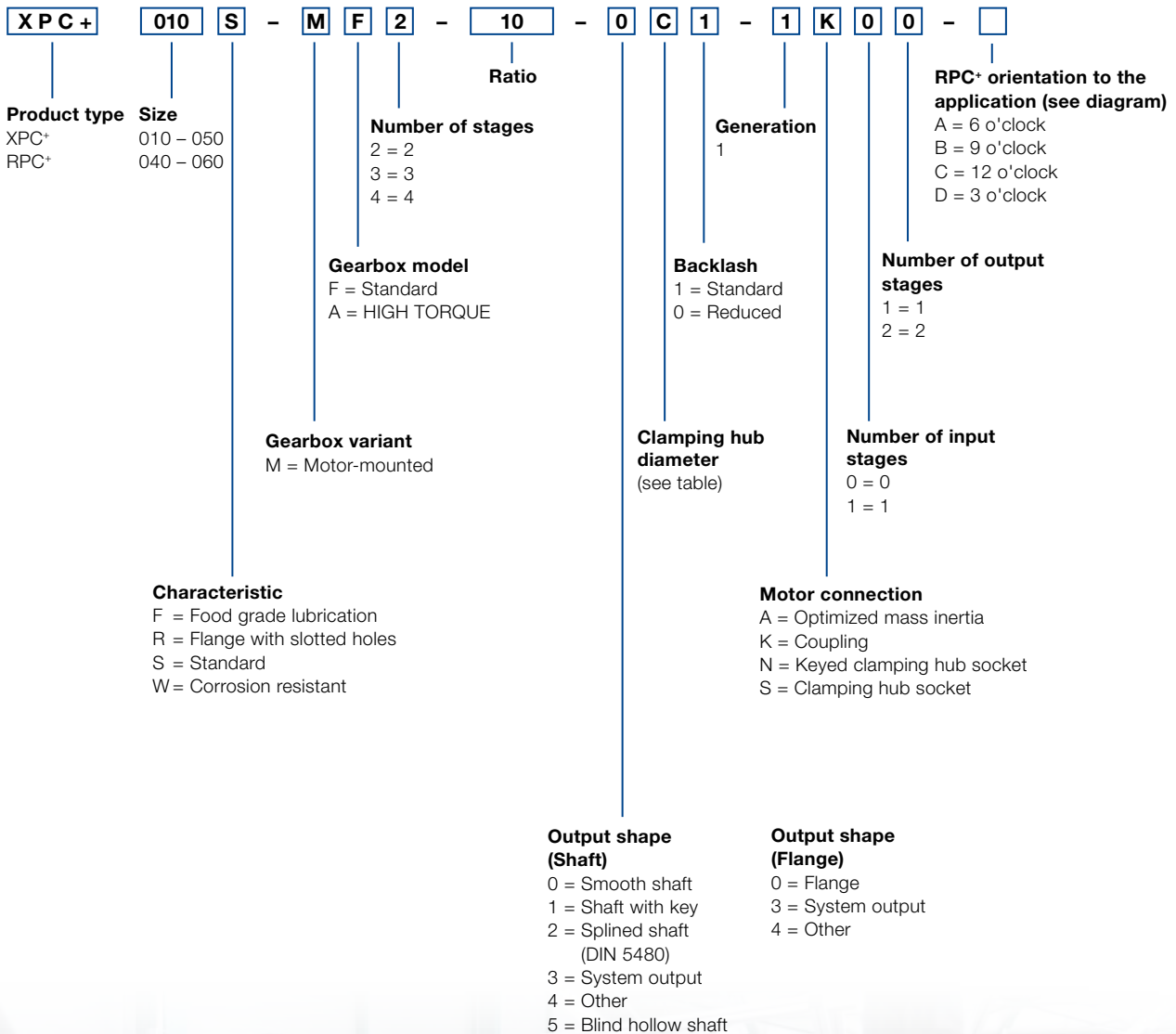

Mounting positions and clamping hub diameters

Planetary gearboxes

B5
Horizontal

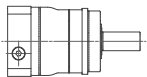

V1
Output vertical downwards

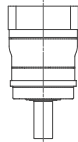

V3
Output vertical upwards

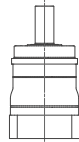

S
Can be tilted $\pm 90^\circ$
from a horizontal position

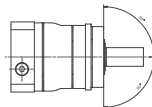

Clamping hub diameter

(see technical data sheet for possible diameters)

Code letter	mm	Code letter	mm
B	11	I	32
C	14	K	38
E	19	M	48
G	24	N	55
H	28		

Intermediate sizes possible using bushings with a minimum thickness of 1 mm.

Hypoid and bevel gearboxes

For information purposes only – not required when placing orders!

Permitted standard mounting positions for right-angle gearboxes (see illustrations)

If the mounting position is different, contact WITTENSTEIN alpha without fail

B5/V3
Output horizontal /
motor shaft vertical upwards

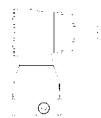

B5/V1
Output horizontal /
motor shaft vertical downwards



V1/B5
Output vertical downwards /
motor shaft horizontal



V3/B5
Output vertical upwards /
motor shaft horizontal

B5/B5
Output horizontal /
motor shaft horizontal

Orientation to the application

Please note the orientation when placing your order.

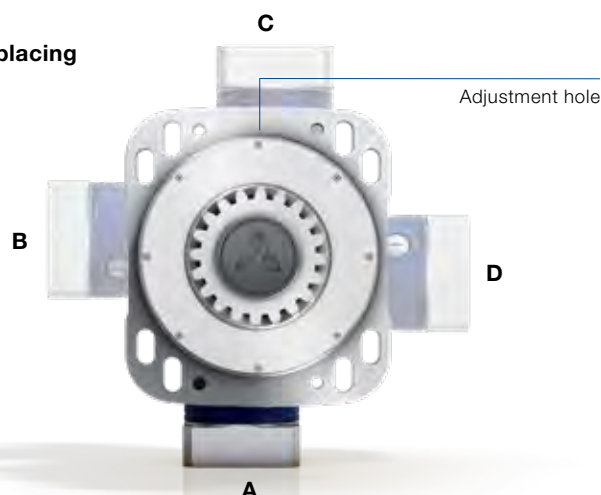



alpha

WITTENSTEIN alpha GmbH
Walter-Wittenstein-Straße 1
97999 Igersheim
Germany

Tel. +49 7931 493-0
24h-Service-Hotline: Tel. +49 7931 493-12900
speedline®: Tel. +49 7931 493-10444
info@wittenstein-alpha.com

Subject to technical changes. alpha Premium Line

WITTENSTEIN alpha – Intelligent drive systems

www.wittenstein-alpha.com

The entire world of drive technology – Catalogs available on request or online at www.wittenstein-alpha.com/catalogs



alpha Premium Line. Unique, individual solutions that offer unparalleled power density.



alpha Advanced Line. Maximum power density and outstanding positioning accuracy for complex applications.



alpha Basic / Value Line. Reliable, flexible and economical solutions for a wide range of applications.



alpha Linear Systems. Precise, dynamic system solutions for every requirement.



alpha Mechatronic Systems. Energy-efficient, versatile and flexible mechatronic drive systems.