



WITTENSTEIN

alpha

Corrosion Resistant / Hygienic Design

Hygienic
Reliable
Resistant



Reliable driving in a hygienically clean environment

Corrosion protection is vitally important for quality and maintenance optimized production – to meet the rising world-wide demand for industrial cleaning technology. Our Corrosion Resistant and EHEDG certified Hygienic Design gear-heads and stainless steel actuators allow hygienic and sterile automation close to the process.

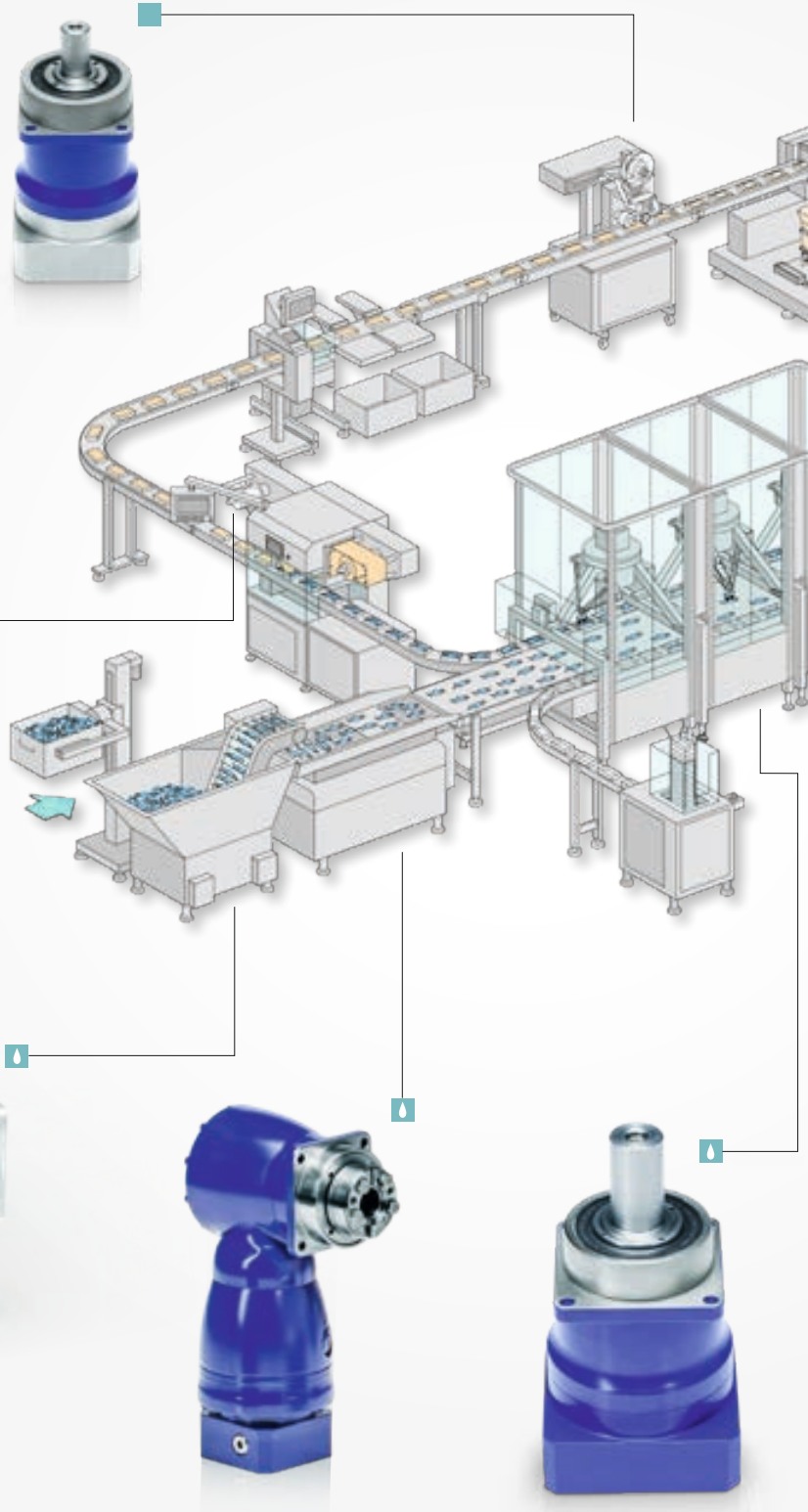

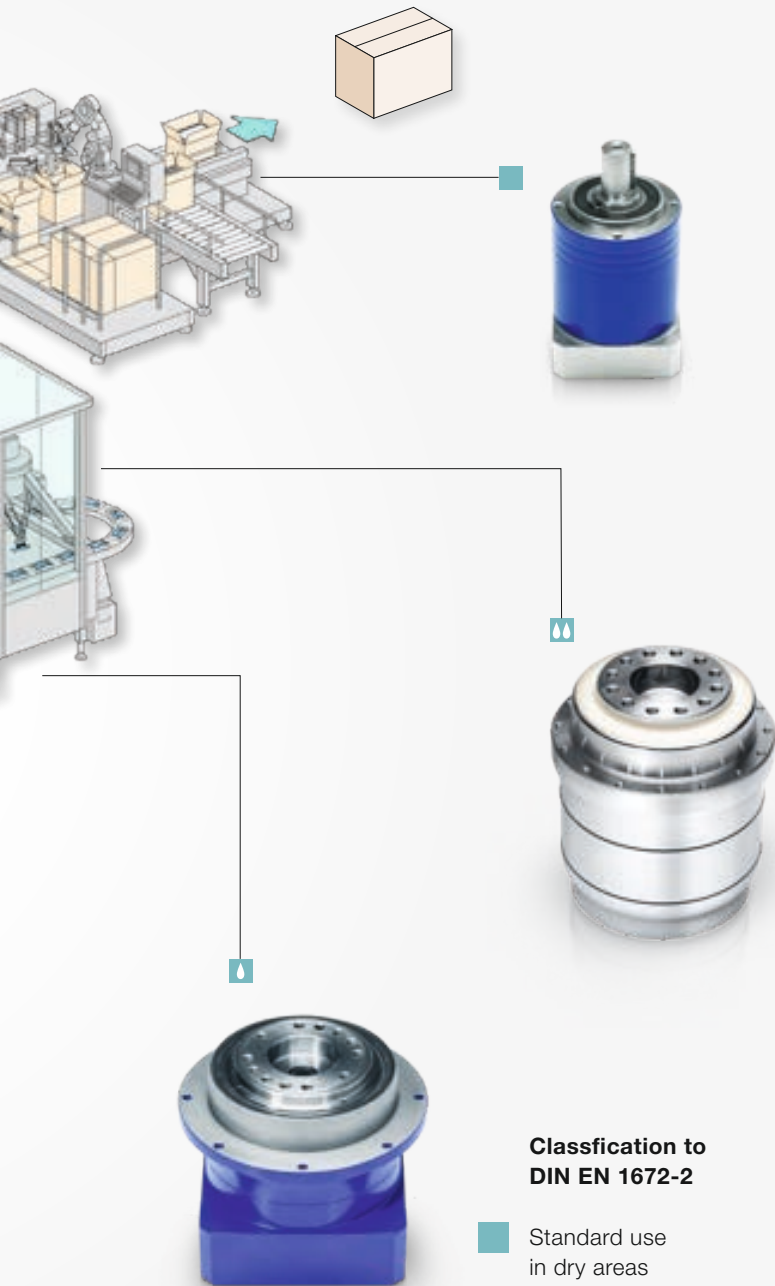

**Classification to
DIN EN 1672-2**

- Standard use
in dry areas
(non-food zone)
- Use in wet or damp
environments
(splash zone)
→ close to the process
- Use in wet areas
(including high-pressure
cleaning) as well as in
contact with cleaning
materials and chemicals
(food zone)
→ integrated in the process

Contents

Corrosion Resistant Design	4
Hygienic Design	5
Applications and benefits	8
axenia servo actuator	9
HDV 015 1-/2-stage	10
HDV 025 1-/2-stage	12
HDV 035 1-/2-stage	14
HDP+ 010 2-stage	16
HDP+ 025 2-stage	18
HDP+ 050 2-stage	20
AXV 060	22
AXV 080	24
AXV 115	26
Ordering codes	28

Corrosion Resistant Design

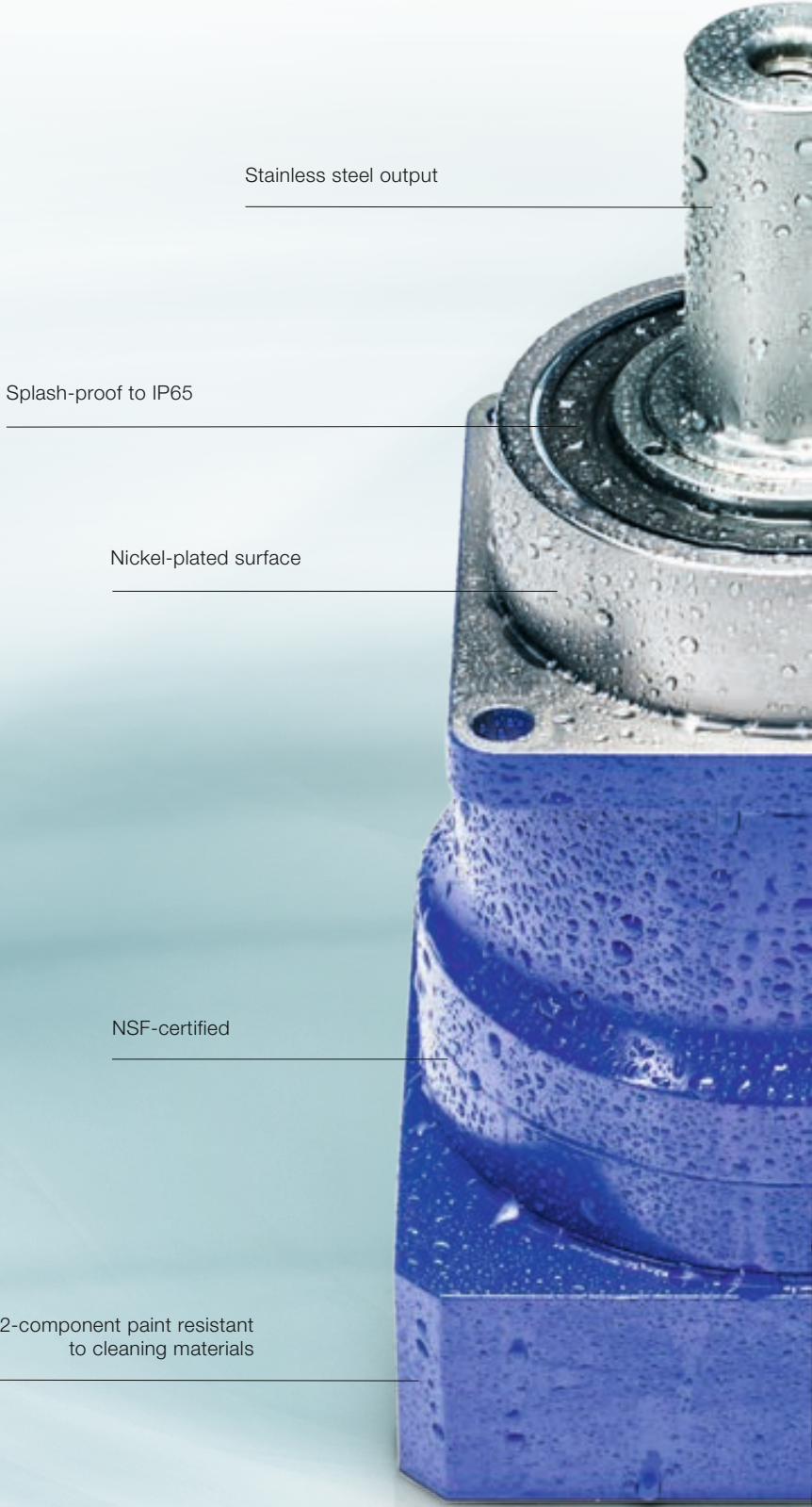

Stainless steel output

Splash-proof to IP65

Nickel-plated surface

NSF-certified

2-component paint resistant
to cleaning materials

Hygienic Design



Seals resistant to cleaning materials have IP69K protection (max. 30 bar)

Triple sealing concept guarantees optimal reliability

Smooth rolled surface in hygienic steel 1.4404 (optionally also in electropolished steel)

EHDG-, FDA-, NSF-certified

No dead spaces



TYPE EL - CLASS I
MAY 2013

Corrosion Resistant Design



SP+ in corrosion resistant design

Protection against corrosion

Our drive solutions provide innovative, incomparable alternatives for applications in corrosive environments.

- Special protective coating
- Food grade lubrication (NSF certified)
- Stainless steel output
- Flexible design:
Compatible with the complete product portfolio
- Optional accessories available:
Stainless steel shrink discs, corrosion proof couplings

Applications:

- Environments with high humidity
- Environments where contact with food occurs
- Delta robots
(e. g. with TP+ in corrosion resistant design)
- Solar industry
- Packaging industry
- Outdoor use

Your benefits:

- Protection against external influences (splash-proof to IP65)
- Protection against flash rust and oxidation
- Easy removal of fouling (germs, microorganisms, etc.)
- Stable processes thanks to WITTENSTEIN alpha quality



TP+ in corrosion resistant design

The compact precision of the TP+ series is ideal for applications where high dynamics are a must.



Hypoid gearhead in corrosion resistant design

Profit from our modular hypoid gearhead system with multiple variants and variable output geometries.

Hygienic Design

Hygienic and sterile

WITTENSTEIN alpha Hygienic Design – the world's first planetary gearhead certified by EHEDG. For a secure and direct process integration.

- EHEDG certified
- Gearhead housing in hygienic steel 1.4404
- Smooth rolled or electropolished surface
- Triple sealing concept (IP69X) (max. 30 bar)
- No dead spaces
- Food grade lubrication (NSF certified)

Your benefits:

- Suited for hygienic and sterile production
- Direct contact with food allowed
- Fast, efficient and reliable cleaning
- Resistant to chemical cleaning materials and disinfectants (e.g. alkalis or acids such as chloride, sulphuric acid, hydrochloric acid)
- Optimal sealing properties
- Maximum resistance to corrosion
- New design freedom because the drive is integrated directly in the process
- High-pressure cleaning also possible depending on the operating environment
- Ideal for any standard motor mounting concept

Applications:

- CIP (cleaning in place)/ SIP (sterilization in place)
- Delta robots
- Food industry (production, processing, packaging, filling)
- Pharmaceutical industry
- Cosmetics industry
- Process technology
- Textile industry
- Medical technology

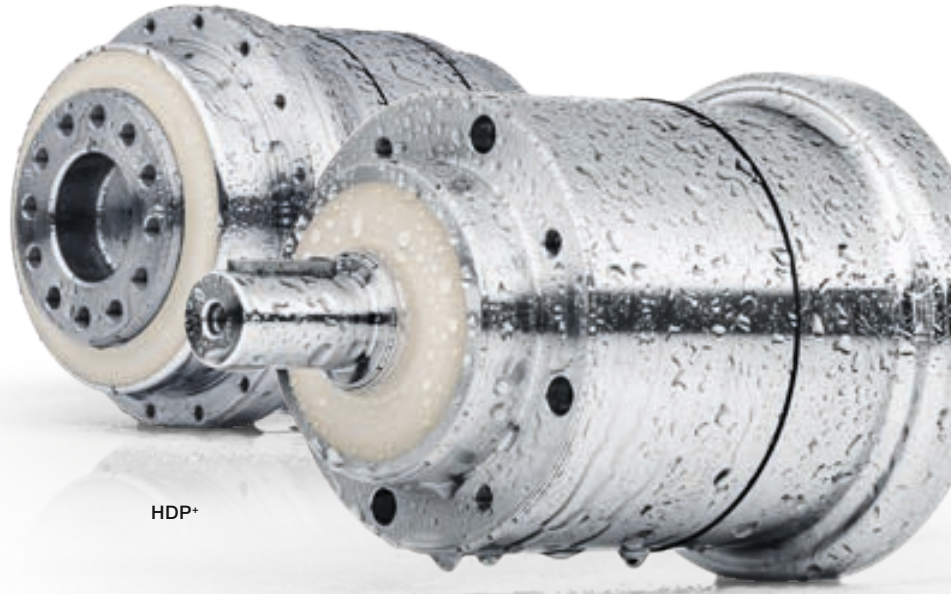

HDP+

HDV



HDP+

Our Hygienic Design gearheads with an output flange represent the solution of choice for highly dynamic and compact applications (e.g. delta robots) involving direct food contact.

EHEDG certified

The principal goal of EHEDG is the promotion of safe food by improving hygienic engineering and design in all aspects of food manufacture.

FDA certified

The Food and Drug Administration is a United States federal agency which regulates food production and approves new drugs. The FDA assures the safety and efficacy of drugs, biological products, medical devices and food supplies.

Applications and benefits

Comparison of installation

	
<p>Conventional solutions: Complicated encapsulation is required to protect the drives.</p> <ul style="list-style-type: none"> · Risk of dirt and moisture build-up under the encapsulation · Surfaces to be cleaned are large · Extra costs (design, cleaning) · Heat build-up under the encapsulation reduces the service life of the drive 	<p>Hygienic solution: New design freedom thanks to the Hygienic Design motor-gearhead unit.</p> <ul style="list-style-type: none"> · Hygienic production because the drive components are cleaned directly · Smaller surfaces save time and cleaning costs · Open drive system extends the service life

Product benefits

- High chemical / corrosion resistance
- High IP protection for optimal sealing
- Design integration Hygienic Design (the complete plant can be designed according to HD principles)
- High power density and dynamics

Benefits for plant manufacturers

- Integration in a plant designed according to hygienic principles (certification available)
- All legal obligations fulfilled (Machinery Directive, food hygiene regulations)
- Easier production / assembly because there are fewer components
- More compact machine design
- Higher overall equipment effectiveness
- Innovative technology / competitive advantage

Benefits for operators

- Easier, faster cleaning: shorter CIP / SIP times
- Improved reliability and longer life
- Quick and easy disassembly
- Reduced consumption of cleaning materials
- Minimal costs for maintenance and repair
- Cost savings: competitive advantage and lower end user price
- Increased food safety

Application examples of food industry



Fish processing



Filling and packing dairy products



Slicing meat products

axenia servo actuator

Technical benefits

- Hygienic design: Cavity-free design
- Long service life through use of CIP-compatible materials
- Integrated, optimized sealing concept
- Resistant against aggressive cleaning agents and disinfectants
- Powerful motor performance
- Low gearhead torsional backlash
- Perfect matched motor-gearhead unit
- Hygienic connection between motor and gearhead

Designed for particularly demanding applications and manufactured from highly resistant stainless steel, with the ability to permanently withstand a wide range of aggressive fluids such as cleaners or disinfectants: axenia is a compact servo actuator which connects the motor to the gearhead with absolute precision and dynamics.

axenia precision:

- Three sizes
- Max. acceleration torque up to 760 Nm
- Torsional backlash ≤ 1 arcmin
- High dynamics and torsional rigidity
- Available on request

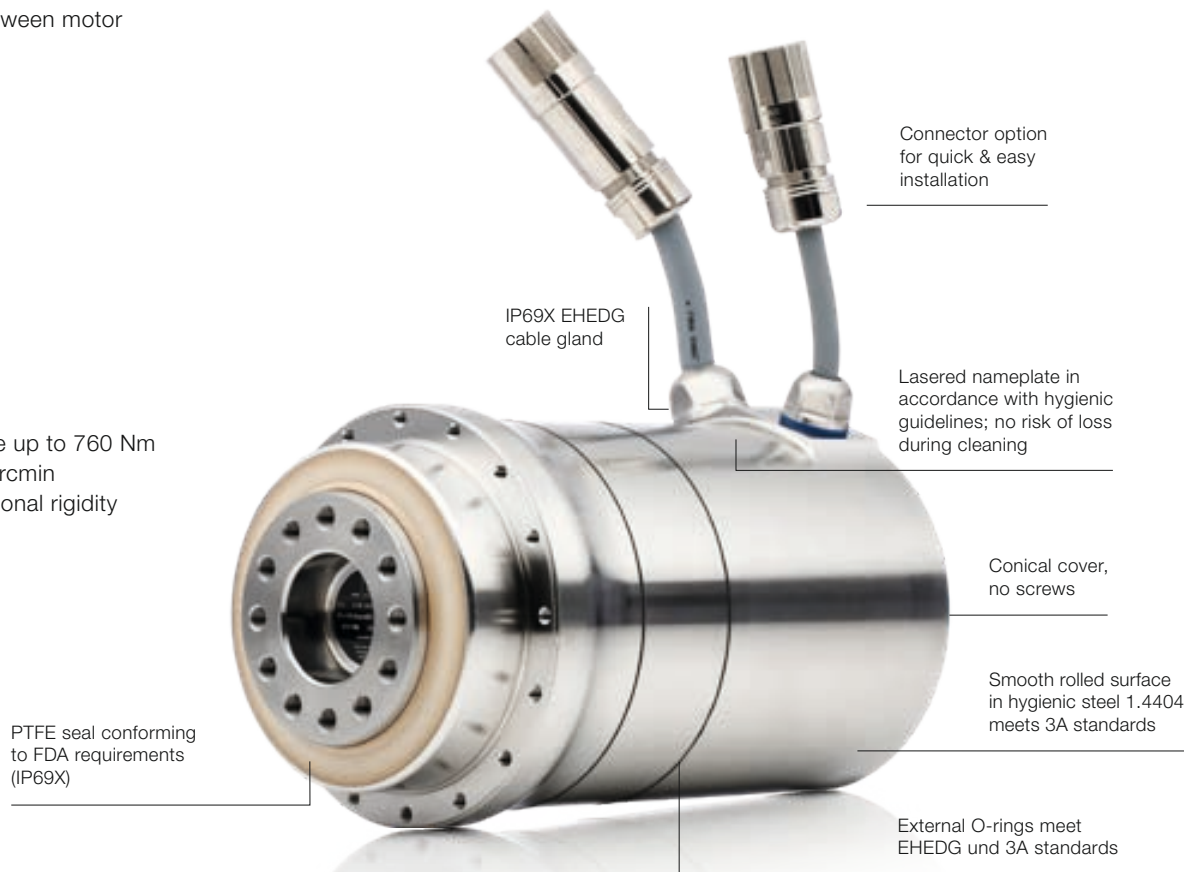

axenia value:

- Three sizes
- Max. acceleration torque up to 200 Nm
- Ratios: 16 to 100
- Large selection of encoder systems
- With or without brake
- Protection class IP69X (max. 30 bar)



axenia AXV 115, 080 and 060 series

HDV 015 1-/2-stage

			1-stage				2-stage							
Ratio	<i>i</i>		4	5	7	10	16	20	25	35	50	70	100	
Maximum acceleration torque (max. 1000 cycles per hour)	T_{2B}	Nm	32	32	32	29	32	32	32	32	32	32	29	
		in.lb	283	283	283	257	283	283	283	283	283	283	257	
Nominal output torque (with n_{in})	T_{2N}	Nm	16	16	16	15	16	16	16	16	16	16	15	
		in.lb	142	142	142	133	142	142	142	142	142	142	133	
Emergency stop torque (permitted 1000 times during the service life of the gearhead)	T_{2Not}	Nm	75	75	75	75	75	75	75	75	75	75	75	
		in.lb	664	664	664	664	664	664	664	664	664	664	664	
Nominal input speed (with T_{2N} and 20°C ambient temperature)	n_{1N}	rpm	3000	3000	3000	3000	3700	3700	3700	3700	3700	3700	3700	
Max. input speed	n_{1Max}	rpm	6000	6000	6000	6000	6000	6000	6000	6000	6000	6000	6000	
Mean no load running torque (with $n_1=3000$ rpm and 20°C gearhead temperature)	T_{012}	Nm	0.15	0.15	0.15	0.15	0.15	0.15	0.15	0.15	0.15	0.15	0.15	
		in.lb	1.33	1.33	1.33	1.33	1.33	1.33	1.33	1.33	1.33	1.33	1.33	
Max. torsional backlash	j_t	arcmin	< 10				< 15							
Torsional rigidity	C_{t12}	Nm/arcmin	2.3	2.3	2.3	2.0	2.3	2.3	2.3	2.3	2.3	2.3	2.0	
		in.lb/arcmin	20	20	20	18	20	20	20	20	20	20	18	
Max. axial force	F_{2AMax}	N	500 / 1000 ^{a)}											
		lb _f	125.5 / 225 ^{a)}											
Max. radial force (refers to center of output shaft at 100 min ⁻¹)	F_{2RMMax}	Nm	350 / 1600 ^{a)}											
		in.lb	78.75 / 360 ^{a)}											
Efficiency at full load	η	%	> 97				> 95							
Service life	L_n	h	> 20000											
Weight incl. standard adapter plate	<i>m</i>	kg	3.2				3.8							
		lb _m	7.1				8.4							
Operating noise (with $n_1=3000$ rpm no load)	L_{PA}	dB(A)	≤ 60											
Max. permitted housing temperature			+90											
			F 194											
Ambient temperature			-25 to +40											
			F 32 to 104											
Lubrication			Lubricated for life H1											
Paint			No paint											
Direction of rotation			Motor and gearhead same direction											
Protection class			IP 69X ^{b)}											
Moment of inertia (relates to the drive)	C	14	J_t	kgcm ²	0.17	0.17	0.17	0.17	0.17	0.17	0.17	0.17	0.17	0.17
				10 ⁻³ in.lb.s ²	0.15	0.15	0.15	0.15	0.15	0.15	0.15	0.15	0.15	0.15
Clamping hub diameter [mm]														

^{a)} Option: reinforced bearing

^{b)} According to DIN 60529:2014-09, max. 30 bar

View A

View B

1-stage:

Clamping hub diameter 14 mm (C)

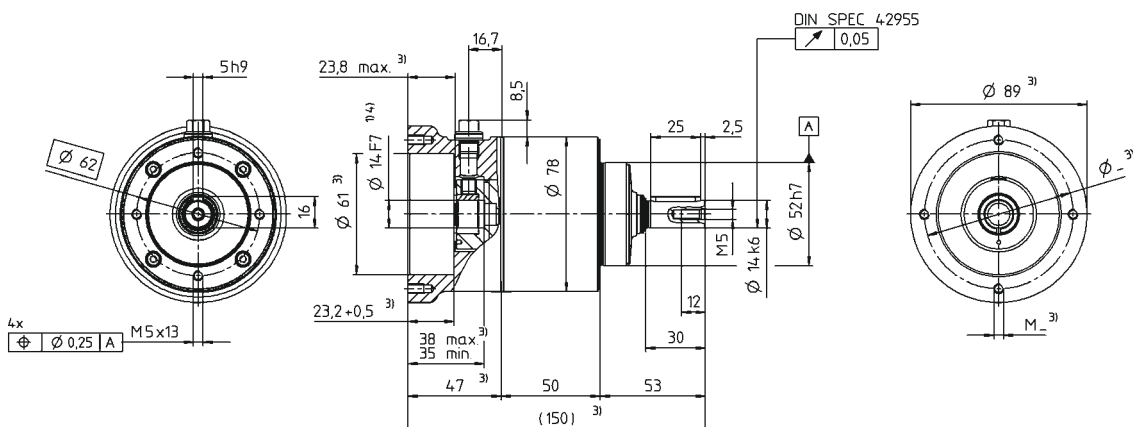

2-stage:

Clamping hub diameter 14 mm (C)

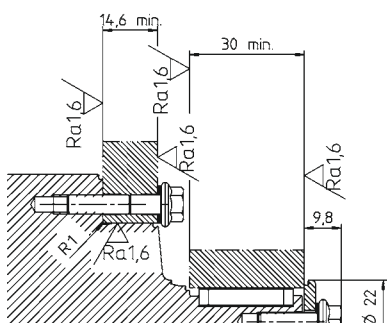
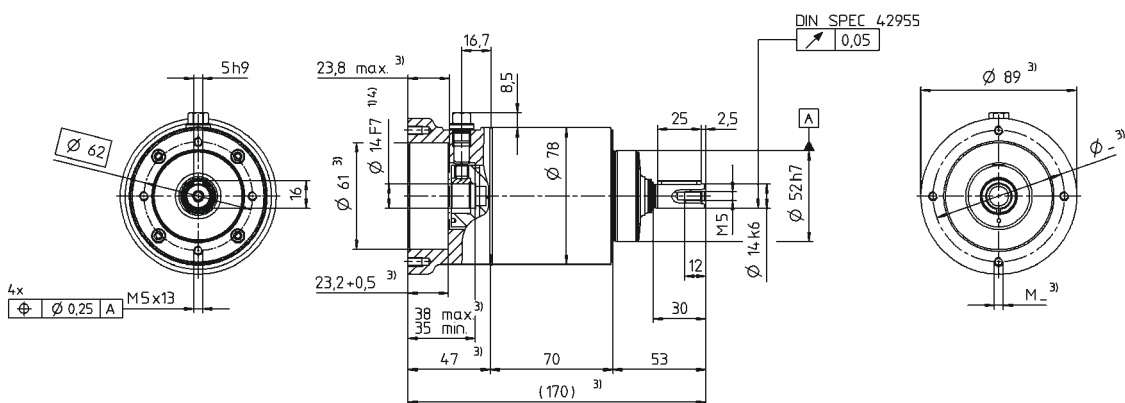

Mounting accessories:
Mounting kit comprising stainless steel screws, washers, seals and O-rings available as an option.

Non-tolerated dimensions ± 1 mm

- 1) Examine motor shaft tolerance
- 2) Min/Max permissible motor shaft length
Longer motor shafts possible
- 3) Measurements are motor-dependent
- 4) Smaller motor shaft diameter is compensated by a bushing with a minimum thickness of 1 mm

Operating Manual at www.wittenstein-us.com

Motor shaft diameter [mm]

HDV 025 1-/2-stage

			1-stage				2-stage							
Ratio	<i>i</i>		4	5	7	10	16	20	25	35	50	70	100	
Maximum acceleration torque (max. 1000 cycles per hour)	T_{2B}	Nm	80	80	80	72	80	80	80	80	80	80	72	
		in.lb	708	708	708	637	708	708	708	708	708	708	637	
Nominal output torque (with n_{in})	T_{2N}	Nm	40	40	40	35	40	40	40	40	40	40	35	
		in.lb	354	354	354	310	354	354	354	354	354	354	310	
Emergency stop torque (permitted 1000 times during the service life of the gearhead)	T_{2Not}	Nm	190	190	190	190	190	190	190	190	190	190	190	
		in.lb	1682	1682	1682	1682	1682	1682	1682	1682	1682	1682	1682	
Nominal input speed (with T_{2N} and 20°C ambient temperature)	n_{1N}	rpm	2700	2700	2700	2700	3400	3400	3400	3400	3400	3400	3400	
Max. input speed	n_{1Max}	rpm	6000	6000	6000	6000	6000	6000	6000	6000	6000	6000	6000	
Mean no load running torque (with $n_1=3000$ rpm and 20°C gearhead temperature)	T_{012}	Nm	0.30	0.30	0.30	0.30	0.30	0.30	0.30	0.30	0.30	0.30	0.30	
		in.lb	2.66	2.66	2.66	2.66	2.66	2.66	2.66	2.66	2.66	2.66	2.66	
Max. torsional backlash	j_t	arcmin	< 10				< 15							
Torsional rigidity	C_{t12}	Nm/arcmin	7.5	7.5	7.5	5.5	7.5	7.5	7.5	7.5	7.5	7.5	5.5	
		in.lb/arcmin	66	66	66	49	66	66	66	66	66	66	49	
Max. axial force	F_{2AMax}	N	500 / 1500 ^{a)}											
		lb _f	112.5 / 337.5 ^{a)}											
Max. radial force (refers to center of output shaft at 100 min ⁻¹)	F_{2RMMax}	Nm	500 / 2500 ^{a)}											
		in.lb	112.5 / 562.5 ^{a)}											
Efficiency at full load	η	%	> 97				> 95							
Service life	L_n	h	> 20000											
Weight incl. standard adapter plate	<i>m</i>	kg	5.2				6.5							
		lb _m	11.5				14.4							
Operating noise (with $n_1=3000$ rpm no load)	L_{PA}	dB(A)	≤ 63											
Max. permitted housing temperature			+90											
			F 194											
Ambient temperature			-25 to +40											
			F 32 to 104											
Lubrication			Lubricated for life H1											
Paint			No paint											
Direction of rotation			Motor and gearhead same direction											
Protection class			IP 69X ^{b)}											
Moment of inertia (relates to the drive)	E	19	J_t	kgcm ²	0.54	0.54	0.54	0.54	0.54	0.54	0.54	0.54	0.54	0.54
				10 ⁻³ in.lb.s ²	0.48	0.48	0.48	0.48	0.48	0.48	0.48	0.48	0.48	0.48
Clamping hub diameter [mm]														

^{a)} Option: reinforced bearing

^{b)} According to DIN 60529:2014-09, max. 30 bar

View A

View B

1-stage:

Clamping hub diameter 19 mm (E)

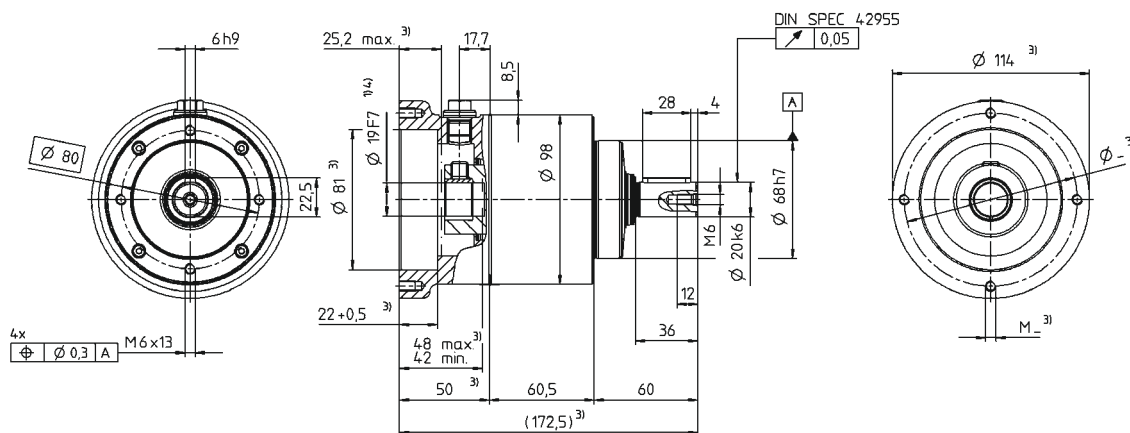

2-stage:

Clamping hub diameter 19 mm (E)

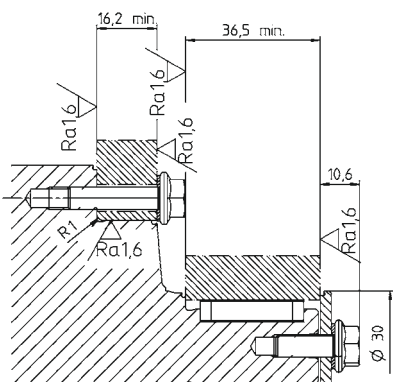
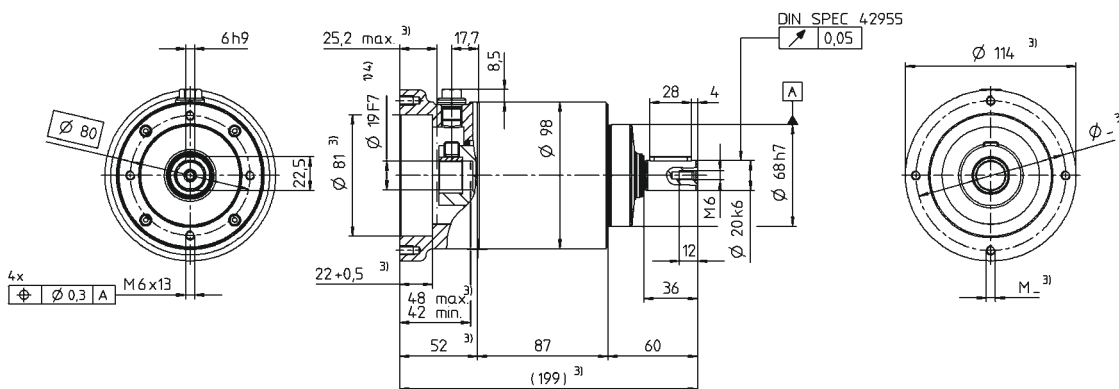

Mounting accessories:
Mounting kit comprising stainless steel screws, washers, seals and O-rings available as an option.

- Non-tolerated dimensions ± 1 mm
- 1) Examine motor shaft tolerance
- 2) Min/Max permissible motor shaft length
Longer motor shafts possible
- 3) Measurements are motor-dependent
- 4) Smaller motor shaft diameter is compensated by a bushing with a minimum thickness of 1 mm

Operating Manual at www.wittenstein-us.com

Motor shaft diameter [mm]

025 HDV

HDV 035 1-/2-stage

			1-stage				2-stage							
Ratio	<i>i</i>		4	5	7	10	16	20	25	35	50	70	100	
Maximum acceleration torque (max. 1000 cycles per hour)	T_{2B}	Nm	200	200	200	180	200	200	200	200	200	200	180	
		in.lb	1770	1770	1770	1593	1770	1770	1770	1770	1770	1770	1593	
Nominal output torque (with n_{in})	T_{2N}	Nm	100	100	100	90	100	100	100	100	100	100	90	
		in.lb	885	885	885	797	885	885	885	885	885	885	797	
Emergency stop torque (permitted 1000 times during the service life of the gearhead)	T_{2Not}	Nm	480	480	480	480	480	480	480	480	480	480	480	
		in.lb	4248	4248	4248	4248	4248	4248	4248	4248	4248	4248	4248	
Nominal input speed (with T_{2N} and 20°C ambient temperature)	n_{1N}	rpm	2000	2000	2000	2000	2600	2600	2600	2600	2600	2600	2600	
Max. input speed	n_{1Max}	rpm	4800	4800	4800	4800	4800	4800	4800	4800	4800	4800	4800	
Mean no load running torque (with $n_1=3000$ rpm and 20°C gearhead temperature)	T_{012}	Nm	0.50	0.50	0.50	0.50	0.50	0.50	0.50	0.50	0.50	0.50	0.50	
		in.lb	4.43	4.43	4.43	4.43	4.43	4.43	4.43	4.43	4.43	4.43	4.43	
Max. torsional backlash	j_t	arcmin	< 10				< 15							
Torsional rigidity	C_{t12}	Nm/arcmin	24.0	24.0	24.0	22.0	24.0	24.0	24.0	24.0	24.0	24.0	22.0	
		in.lb/arcmin	212	212	212	195	212	212	212	212	212	212	195	
Max. axial force	F_{2AMax}	N	1700 / 3000 ^{a)}											
		lb _f	382.5 / 675 ^{a)}											
Max. radial force (refers to center of output shaft at 100 min ⁻¹)	F_{2RMMax}	Nm	1200 / 4250 ^{a)}											
		in.lb	270 / 956 ^{a)}											
Efficiency at full load	η	%	> 97				> 95							
Service life	L_n	h	> 20000											
Weight incl. standard adapter plate	<i>m</i>	kg	13.6				16.6							
		lb _m	30.1				36.7							
Operating noise (with $n_1=3000$ rpm no load)	L_{PA}	dB(A)	≤ 68											
Max. permitted housing temperature			+90											
			F 194											
Ambient temperature			-25 to +40											
			F 32 to 104											
Lubrication			Lubricated for life H1											
Paint			No paint											
Direction of rotation			Motor and gearhead same direction											
Protection class			IP 69X ^{b)}											
Moment of inertia (relates to the drive)	G	24	J_t	kgcm ²	1.80	1.80	1.80	1.80	1.80	1.80	1.80	1.80	1.80	1.80
				10 ⁻³ in.lb.s ²	1.59	1.59	1.59	1.59	1.59	1.59	1.59	1.59	1.59	1.59
Clamping hub diameter [mm]														

^{a)} Option: reinforced bearing

^{b)} According to DIN 60529:2014-09, max. 30 bar

View A

View B

1-stage:

Clamping hub diameter 24 mm (G)

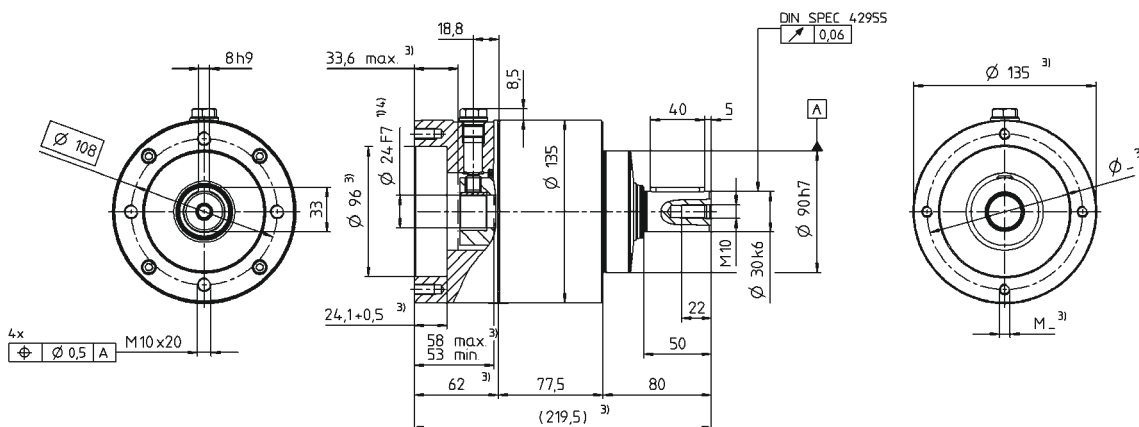

2-stage:

Clamping hub diameter 24 mm (G)

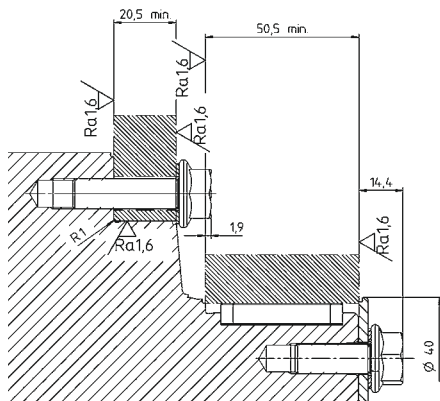
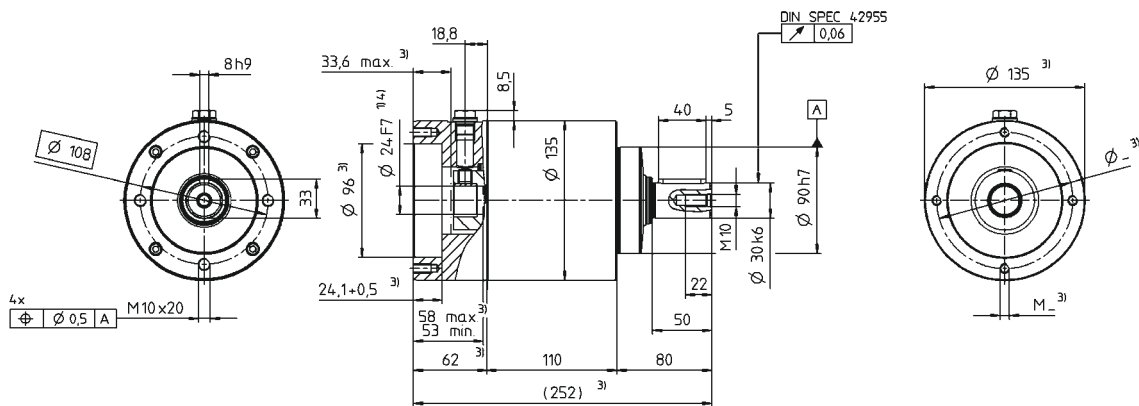

Mounting accessories:
Mounting kit comprising stainless steel screws, washers, seals and O-rings available as an option.

Non-tolerated dimensions ± 1 mm

- 1) Examine motor shaft tolerance
- 2) Min/Max permissible motor shaft length
Longer motor shafts possible
- 3) Measurements are motor-dependent
- 4) Smaller motor shaft diameter is compensated by a bushing with a minimum thickness of 1 mm

⚠ Operating Manual at www.wittenstein-us.com

Motor shaft diameter [mm]

035 HDV

HDP+ 010 2-stage

				2-stage				
Ratio		<i>i</i>		22	27.5	38.5	55	
Maximum acceleration torque (max. 1000 cycles per hour)	T_{2B}	Nm		185	185	185	185	
		in.lb		1637	1637	1637	1637	
Nominal output torque (with n_{in})	T_{2N}	Nm		120	120	145	90	
		in.lb		1062	1062	1283	797	
Emergency stop torque (permitted 1000 times during the service life of the gearhead)	T_{2Not}	Nm		525	525	525	525	
		in.lb		4646	4646	4646	4646	
Nominal input speed (with T_{2N} and 20°C ambient temperature)	n_{1N}	rpm		4000	4000	4000	4000	
Max. input speed	n_{1Max}	rpm		6000	6000	6000	6000	
Mean no load running torque (with $n_1=3000$ rpm and 20°C gearhead temperature)	T_{012}	Nm		0.60	0.50	0.45	0.35	
		in.lb		5.31	4.43	3.98	3.10	
Max. torsional backlash	j_t	arcmin		≤ 1				
Torsional rigidity	C_{t12}	Nm/arcmin		43	43	43	42	
		in.lb/arcmin		381	381	381	372	
Tilting rigidity	C_{2K}	Nm/arcmin		225				
		in.lb/arcmin		1991				
Max. axial force	F_{2AMax}	N		2150				
		lb _f		484				
Max. tilting moment	M_{2KMax}	Nm		400				
		in.lb		3540				
Efficiency at full load	η	%		> 94				
Service life	L_n	h		> 20000				
Weight incl. standard adapter plate	m	kg		7.3				
		lb _m		16.1				
Operating noise (with $n_1=3000$ rpm no load)	L_{PA}	dB(A)		≤ 54				
Max. permitted housing temperature			+90					
			F					
Ambient temperature			-15 to +40					
			°C					
				F				
				32 to 104				
Lubrication				Lubricated for life H1				
Paint				No paint				
Direction of rotation				Motor and gearhead same direction				
Protection class				IP 69X ^{a)}				
Moment of inertia (relates to the drive)	C	14	J_1	kgcm ²	0.21	0.18	0.16	0.14
				10 ⁻³ in.lb.s ²	0.19	0.16	0.14	0.12
Clamping hub diameter [mm]	E	19	J_1	kgcm ²	0.52	0.50	0.47	0.46
				10 ⁻³ in.lb.s ²	0.46	0.44	0.42	0.41

^{a)} According to DIN 60529:2014-09, max. 30 bar

View A

View B

2-stage:

Clamping hub diameter 14 mm (C)
 Additional available clamping hub diameter 19 mm (E)

Motor shaft diameter [mm]

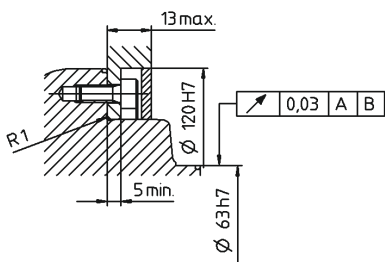
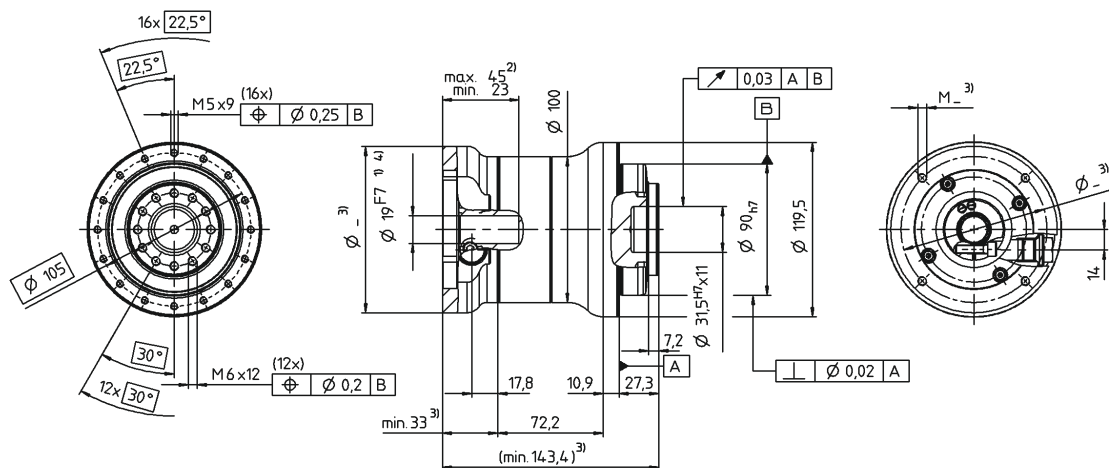
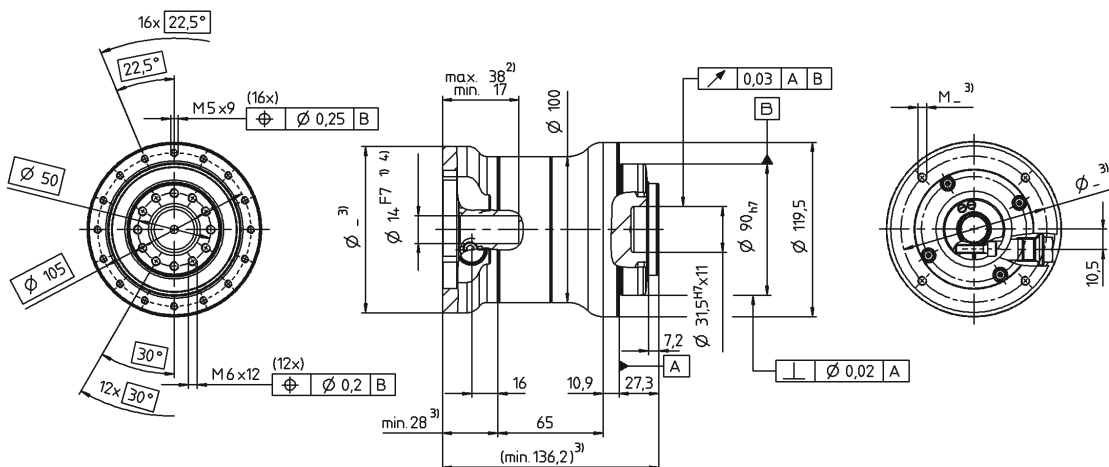

Mounting accessories:
 Mounting kit comprising seals and O-rings available as an option.

Non-tolerated dimensions ± 1 mm

- 1) Examine motor shaft tolerance
- 2) Min/Max permissible motor shaft length
 Longer motor shafts possible
- 3) Measurements are motor-dependent
- 4) Smaller motor shaft diameter is compensated by a bushing with a minimum thickness of 1 mm

⚠ Operating Manual at www.wittenstein-us.com

HDP+ 025 2-stage

				2-stage				
Ratio		i		22	27.5	38.5	55	
Maximum acceleration torque (max. 1000 cycles per hour)	T_{2B}	Nm		425	425	425	425	
		in.lb		3761	3761	3761	3761	
Nominal output torque (with n_{in})	T_{2N}	Nm		255	280	300	300	
		in.lb		2257	2478	2655	2655	
Emergency stop torque (permitted 1000 times during the service life of the gearhead)	T_{2Not}	Nm		1200	1200	1200	1200	
		in.lb		10620	10620	10620	10620	
Nominal input speed (with T_{2N} and 20°C ambient temperature)	n_{1N}	rpm		3500	3500	3500	3500	
Max. input speed	n_{1Max}	rpm		6000	6000	6000	6000	
Mean no load running torque (with $n_1=3000$ rpm and 20°C gearhead temperature)	T_{012}	Nm		1.10	1.00	0.80	0.60	
		in.lb		9.74	8.85	7.08	5.31	
Max. torsional backlash	j_t	arcmin		≤ 1				
Torsional rigidity	C_{t12}	Nm/arcmin		100	100	100	95	
		in.lb/arcmin		885	885	885	841	
Tilting rigidity	C_{2K}	Nm/arcmin		550				
		in.lb/arcmin		4868				
Max. axial force	F_{2AMax}	N		4150				
		lb _f		934				
Max. tilting moment	M_{2KMax}	Nm		550				
		in.lb		4868				
Efficiency at full load	η	%		> 94				
Service life	L_n	h		> 20000				
Weight incl. standard adapter plate	m	kg		11.1				
		lb _m		24.5				
Operating noise (with $n_1=3000$ rpm no load)	L_{PA}	dB(A)		≤ 58				
Max. permitted housing temperature			+90					
			F					
Ambient temperature			-15 to +40					
			°C					
Lubrication			32 to 104					
			F					
Lubrication			Lubricated for life H1					
Paint			No paint					
Direction of rotation			Motor and gearhead same direction					
Protection class			IP 69X ^{a)}					
Moment of inertia (relates to the drive)	E	19	J_1	kgcm ²	0.87	0.70	0.60	0.55
				10 ⁻³ in.lb.s ²	0.77	0.62	0.53	0.49
Clamping hub diameter [mm]	G	24	J_1	kgcm ²	2.39	2.22	2.12	2.07
				10 ⁻³ in.lb.s ²	2.12	1.96	1.88	1.83

^{a)} According to DIN 60529:2014-09, max. 30 bar

View A

View B

2-stage:

Clamping hub diameter 19 mm (E)

Additional available clamping hub diameter 24 mm (G)

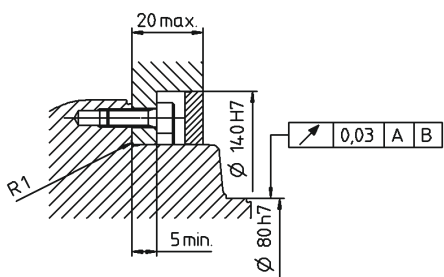
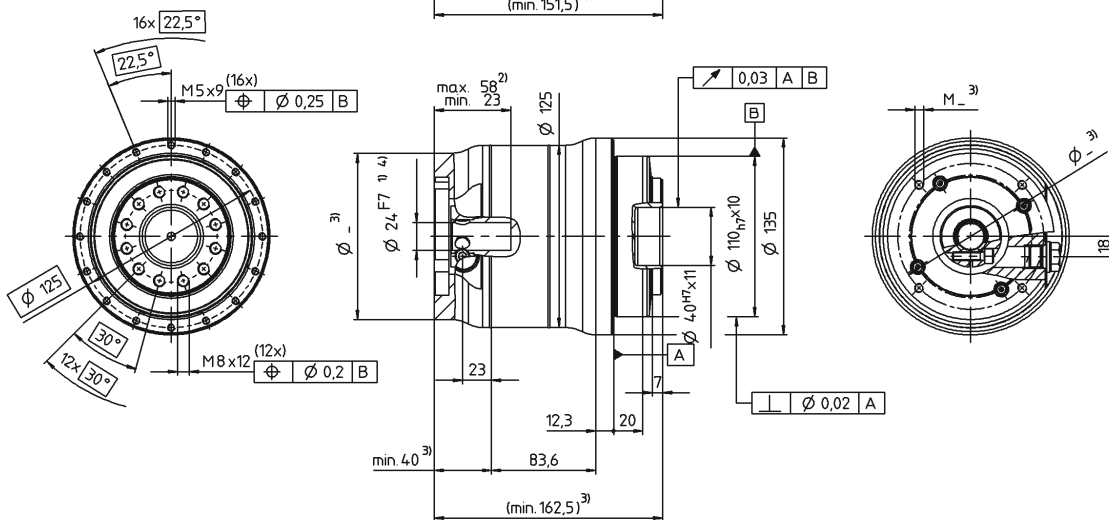
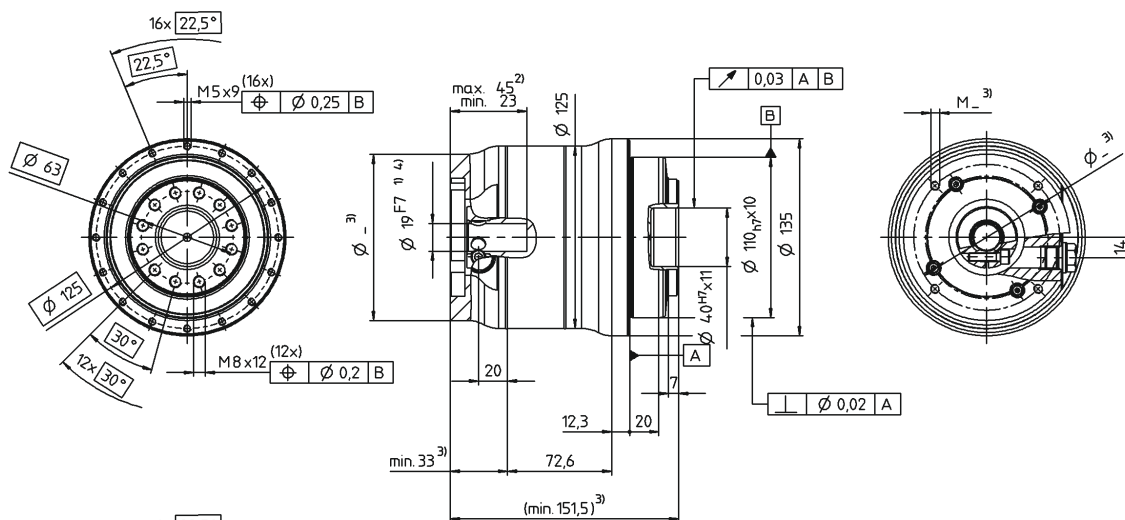

Mounting accessories:
Mounting kit comprising seals and O-rings available as an option.

Non-tolerated dimensions ± 1 mm

- 1) Examine motor shaft tolerance
- 2) Min/Max permissible motor shaft length
Longer motor shafts possible
- 3) Measurements are motor-dependent
- 4) Smaller motor shaft diameter is compensated by a bushing with a minimum thickness of 1 mm

⚠ Operating Manual at www.wittenstein-us.com

Motor shaft diameter [mm]

025 HDP+

HDP+ 050 2-stage

				2-stage				
Ratio		i		22	27.5	38.5	55	
Maximum acceleration torque (max. 1000 cycles per hour)	T_{2B}	Nm		760	760	760	760	
		in.lb		6726	6726	6726	6726	
Nominal output torque (with n_{in})	T_{2N}	Nm		460	480	520	540	
		in.lb		4071	4248	4602	4779	
Emergency stop torque (permitted 1000 times during the service life of the gearhead)	T_{2Not}	Nm		2375	2375	2375	2375	
		in.lb		21019	21019	21019	21019	
Nominal input speed (with T_{2N} and 20°C ambient temperature)	n_{1N}	rpm		3000	3000	3000	3000	
Max. input speed	n_{1Max}	rpm		5000	5000	5000	5000	
Mean no load running torque (with $n_1=3000$ rpm and 20°C gearhead temperature)	T_{012}	Nm		3.7	2.90	2.00	1.70	
		in.lb		32.75	25.67	17.70	15.05	
Max. torsional backlash	j_t	arcmin		≤ 1				
Torsional rigidity	C_{t12}	Nm/arcmin		210	210	210	210	
		in.lb/arcmin		1858.5	1858.5	1858.5	1858.5	
Tilting rigidity	C_{2K}	Nm/arcmin		560				
		in.lb/arcmin		4956				
Max. axial force	F_{2AMax}	N		6130				
		lb _f		1379				
Max. tilting moment	M_{2KMax}	Nm		1335				
		in.lb		11815				
Efficiency at full load	η	%		> 94				
Service life	L_n	h		> 20000				
Weight incl. standard adapter plate	m	kg		21.9				
		lb _m		48.4				
Operating noise (with $n_1=3000$ rpm no load)	L_{PA}	dB(A)		≤ 60				
Max. permitted housing temperature			+90					
			F					
Ambient temperature			-15 to +40					
			°C					
				F				
				32 to 104				
Lubrication				Lubricated for life H1				
Paint				No paint				
Direction of rotation				Motor and gearhead same direction				
Protection class				IP 69X ^{a)}				
Moment of inertia (relates to the drive)	G	24	J_1	kgcm ²	3.76	3.32	3.01	2.82
				10 ⁻³ in.lb.s ²	3.33	2.94	2.66	2.50
Clamping hub diameter [mm]	K	38	J_1	kgcm ²	10.7	10.3	9.92	9.73
				10 ⁻³ in.lb.s ²	9.47	9.12	8.78	8.61

^{a)} According to DIN 60529:2014-09, max. 30 bar

View A

View B

2-stage:

Clamping hub diameter 24 mm (G)
 Additional available clamping hub diameter 38 mm (K)

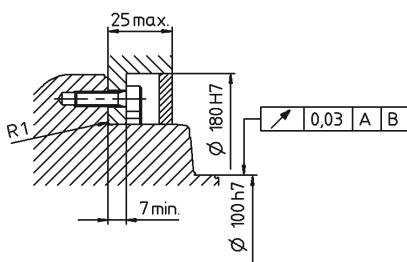
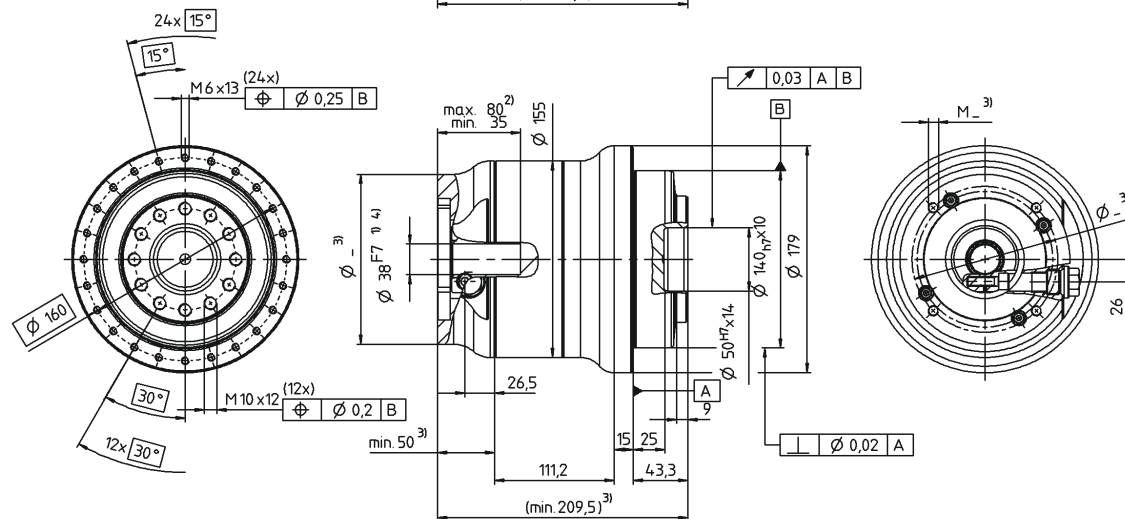
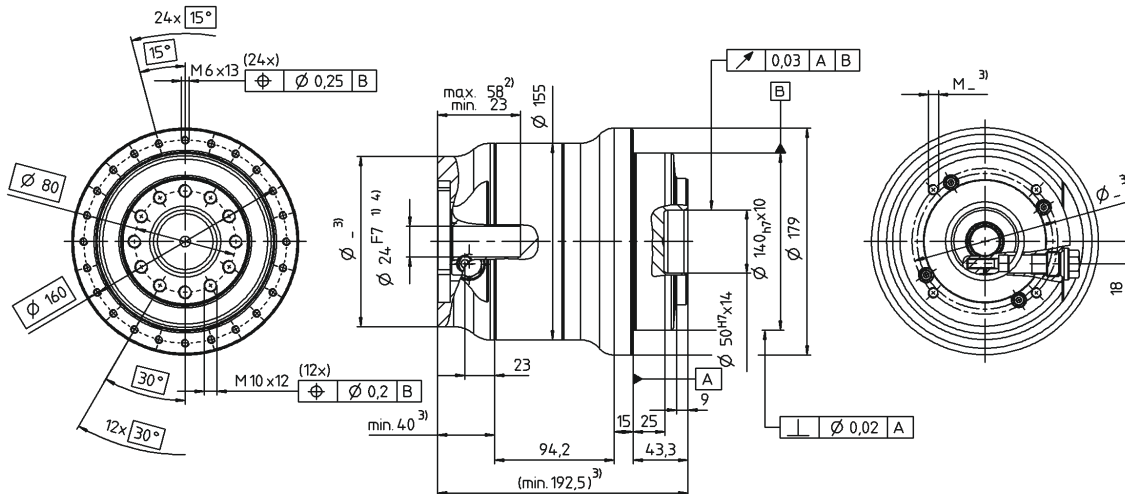

Mounting accessories:
 Mounting kit comprising seals and O-rings available as an option.

Non-tolerated dimensions ± 1 mm

- 1) Examine motor shaft tolerance
- 2) Min/Max permissible motor shaft length
 Longer motor shafts possible
- 3) Measurements are motor-dependent
- 4) Smaller motor shaft diameter is compensated by a bushing with a minimum thickness of 1 mm

⚠ Operating Manual at www.wittenstein-us.com

Motor shaft diameter [mm]

050
HDP+

Ratio	i	16	20	25	50	70	100	
Intermediate circuit voltage	V_{DC}	560						
Max. acceleration torque at output	T_{2B}	Nm	21	26	32	30	32	29
		in.lb	186	230	283	266	283	257
Static output torque	T_{20}	Nm	7.5	9.4	11.8	8.2	11.5	15
		in.lb	66	83	104	73	102	133
Brake holding torque at output (100°C)	T_{2BR}	Nm	17.6	22	27.5	55 ^{a)}	77 ^{a)}	110 ^{a)}
		in.lb	156	195	243	487	682	974
Max. speed	n_{2Max} rpm	375	300	240	120	86	60	
Max. motor acceleration torque	T_{Mmax}	Nm	1.4			0.7		
		in.lb	12.4			6.2		
Max. motor acceleration current	I_{Maxdyn} A_{eff}	2.3			1.7			
Actuator mass moment of inertia at MS	J_t	kgcm ²	0.35			0.28		
		10 ⁻³ in.lb.s ²	0.31			0.25		
Backlash	j_t arcmin	≤ 15						
Torsional rigidity	C_{t21}	Nm/arcmin	2.3				2	
		in.lb/arcmin	20				18	
Max. axial force	F_{2AMax}	N	1000					
		lb ^f	225					
Max. radial force (relative to shaft center at 100 rpm)	F_{2RMax}	N	1600					
		lb ^f	360					
Bearing lifespan	L_n h	20000						
Weight (with resolver, without brake)	m	kg	6					
		lb ^m	13					
Operating noise (at $n_1 = 3000$ rpm)	L_{PA} dB(A)	≤ 60						
Max. perm. motor surface temperature	°C	135						
Max. perm. gearhead surface temperature	°C	90						
Insulating material class		F						
Ambient temperature	°C	0 bis +40						
Protection class		IP 66 / IP 69X ^{b)}						
Lubrication		Lubricated for life H1						
Mount. pos.		Any ^{c)}						

^{a)} Greater than T_{2B} of the gearhead. In an emergency, can be used approx. 1000 times while the motor is rotating.

^{b)} At 30 bar, based on DIN40050-9.

^{c)} Preferably horizontal mounting position with cable outlet facing downwards.

View A

View B

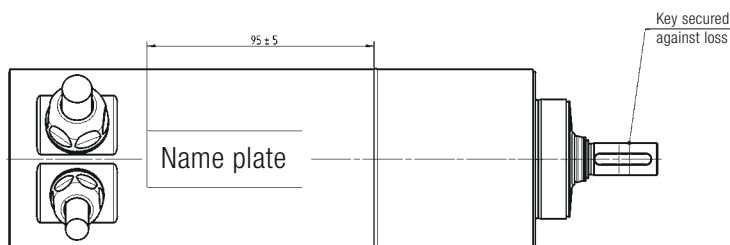
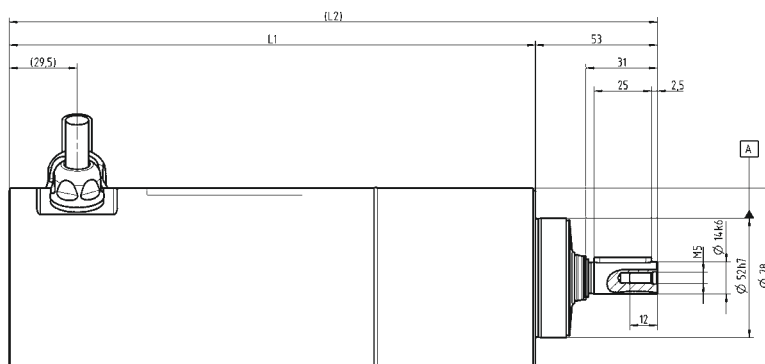
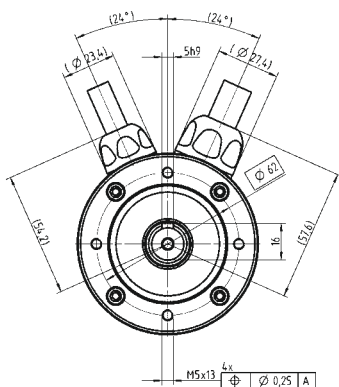

Ratio	Length L1 [mm]	Length L2 [mm]
Dual-stage (16, 20, 25, 50, 70, 100)	229	282

Non-tolerated dimensions ± 1 mm

Output data

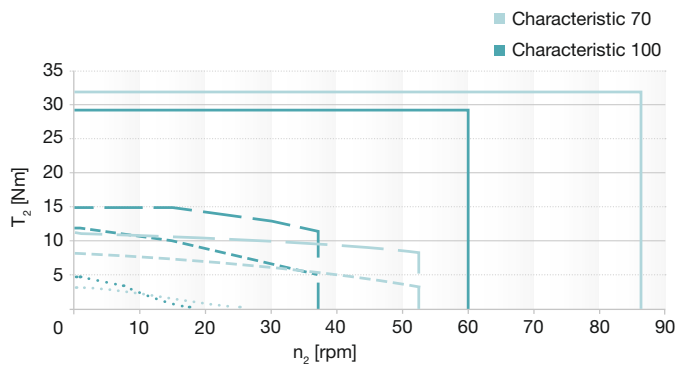
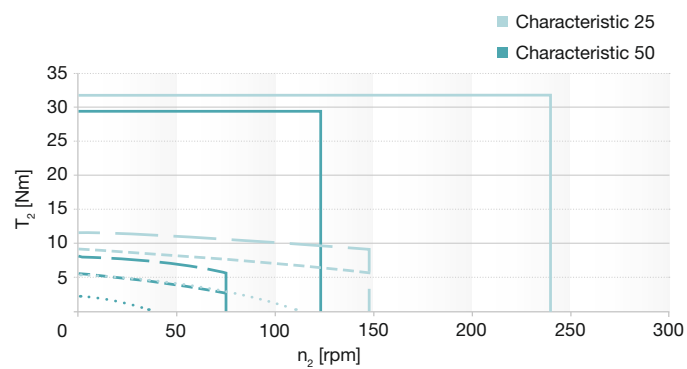
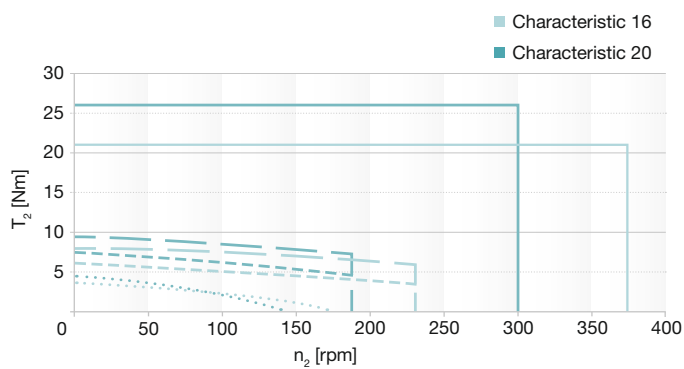

- Short-term maximum torque
- - - Permanent torque curve S1
- - - Permanent torque curve S1 50K
- Permanent torque curve S1 30K

Ratio	i	16	20	25	50	70	100	
Intermediate circuit voltage	V_{DC}	560						
Max. acceleration torque at output	T_{2B}	Nm	50	62	78	48	67	72
		in.lb	443	549	690	425	593	637
Static output torque	T_{20}	Nm	21	26.2	32.8	15	21	30
		in.lb	186	232	290	133	186	266
Brake holding torque at output (100°C)	T_{2BR}	Nm	18	17.6	27.5	55 ^{a)}	77 ^{a)}	110 ^{a)}
		in.lb	159	156	243	487	682	974
Max. speed	n_{2Max} rpm	375	300	240	120	86	60	
Max. motor acceleration torque	T_{Mmax}	Nm	3.4			1.24		
		in.lb	30.1			11.0		
Max. motor acceleration current	I_{Maxdyn} A_{eff}	4.4			1.77			
Actuator mass moment of inertia at MS	J_t	kgcm ²	0.98			0.7		
		10 ⁻³ in.lb.s ²	0.86			0.62		
Backlash	j_t arcmin	≤ 15						
Torsional rigidity	C_{t21}	Nm/arcmin	7.5				5.5	
		in.lb/arcmin	66				49	
Max. axial force	F_{2AMax}	N	1500					
		lb ^f	337					
Max. radial force (relative to shaft center at 100 rpm)	F_{2RMax}	N	2500					
		lb ^f	562					
Bearing lifespan	L_n h	20000						
Weight (with resolver, without brake)	m	kg	11.5					
		lb ^m	25					
Operating noise (at $n_1 = 3000$ rpm)	L_{PA} dB(A)	≤ 63						
Max. perm. motor surface temperature	°C	135						
Max. perm. gearhead surface temperature	°C	90						
Insulating material class		F						
Ambient temperature	°C	0 bis +40						
Protection class		IP 66 / IP 69X ^{b)}						
Lubrication		Lubricated for life H1						
Mount. pos.		Any ^{c)}						

^{a)} Greater than T_{2B} of the gearhead. In an emergency, can be used approx. 1000 times while the motor is rotating.

^{b)} At 30 bar, based on DIN40050-9.

^{c)} Preferably horizontal mounting position with cable outlet facing downwards.

View A

View B

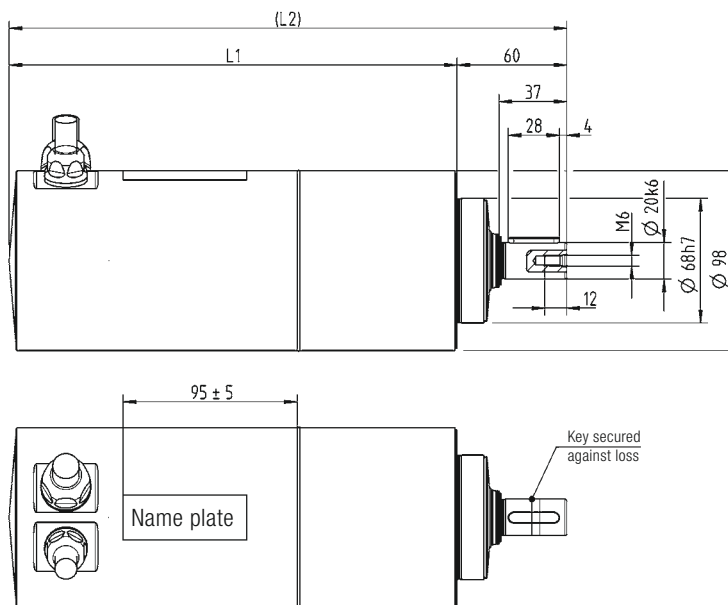
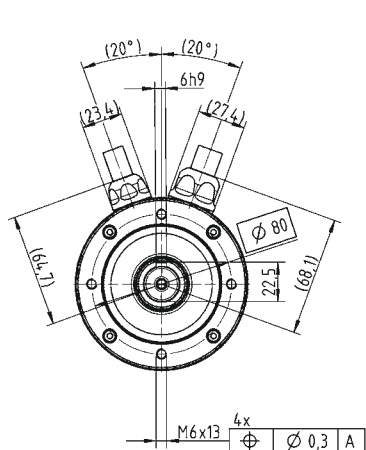

Ratio	Length L1 [mm]	Length L2 [mm]
Dual-stage (16, 20, 25, 50, 70, 100)	244.5	304.5

Non-tolerated dimensions ± 1 mm

Output data

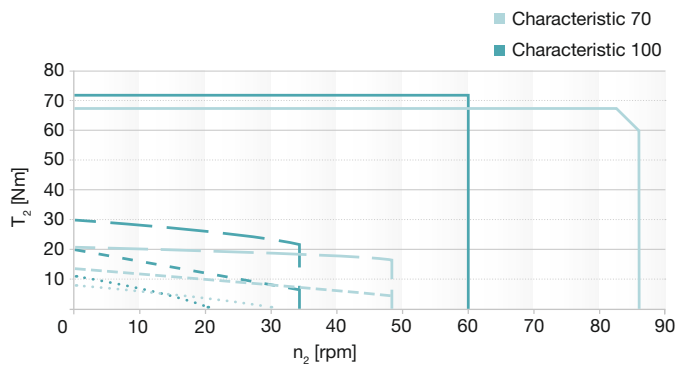
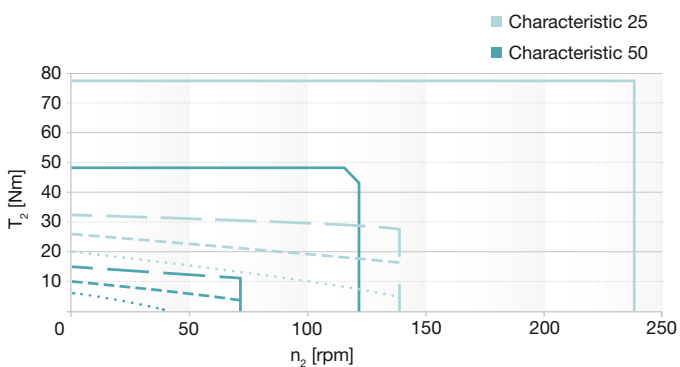
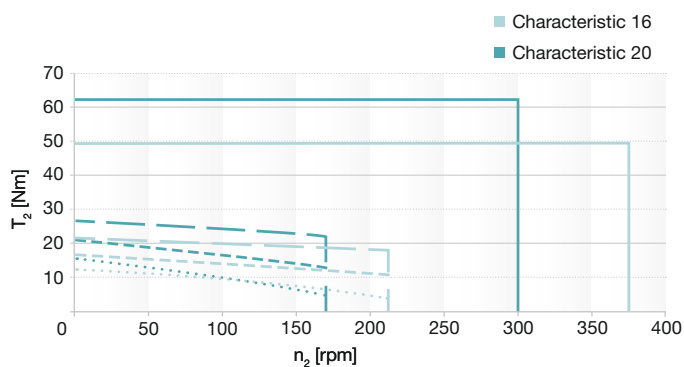

- Short-term maximum torque
- - - Permanent torque curve S1
- - - Permanent torque curve S1 50K
- Permanent torque curve S1 30K

Motor shaft diameter [mm]

Ratio	i	16	20	25	50	70	100	
Intermediate circuit voltage	V_{DC}	560						
Max. acceleration torque at output	T_{2B}	Nm	145	181	200	152	200	180
		in.lb	1283	1602	1770	1345	1770	1593
Static output torque	T_{20}	Nm	57	71	88	42	58	83
		in.lb	504	628	779	372	513	735
Brake holding torque at output (100°C)	T_{2BR}	Nm	72	90	113	225 ^{a)}	315 ^{a)}	450 ^{a)}
		in.lb	637	797	1000	1991	2788	3983
Max. speed	n_{2Max} rpm	300	240	192	96	69	48	
Max. motor acceleration torque	T_{Mmax}	Nm	9.55			3.53		
		in.lb	84.5			31.2		
Max. motor acceleration current	I_{Maxdyn} A_{eff}	12.9			4.8			
Actuator mass moment of inertia at MS	J_t	kgcm ²	3.73			2.51		
		10 ⁻³ in.lb.s ²	3.28			2.21		
Backlash	j_t arcmin	≤ 15						
Torsional rigidity	C_{t21}	Nm/arcmin	24				22	
		in.lb/arcmin	212				195	
Max. axial force	F_{2AMax}	N	3000					
		lb ^f	674					
Max. radial force (relative to shaft center at 100 rpm)	F_{2RMax}	N	4250					
		lb ^f	955					
Bearing lifespan	L_n h	20000						
Weight (with resolver, without brake)	m	kg	21					
		lb ^m	46					
Operating noise (at $n_1 = 3000$ rpm)	L_{PA} dB(A)	≤ 68						
Max. perm. motor surface temperature	°C	135						
Max. perm. gearhead surface temperature	°C	90						
Insulating material class		F						
Ambient temperature	°C	0 bis +40						
Protection class		IP 66 / IP 69X ^{b)}						
Lubrication		Lubricated for life H1						
Mount. pos.		Any ^{c)}						

^{a)} Greater than T_{2B} of the gearhead. In an emergency, can be used approx. 1000 times while the motor is rotating.

^{b)} At 30 bar, based on DIN40050-9.

^{c)} Preferably horizontal mounting position with cable outlet facing downwards.

Order codes

Gearhead type HDV 015 HDV 025 HDV 035	Type code S = Smoothed surface Z = Electropolished	Gearhead variations M = Motor attachment gearhead	Gearhead model F = Standard T = Reinforced bearing	Number of stages 1 = 1-stage 2 = 2-stage
Ratios See technical data sheets	Output shape 0 = Smooth shaft 1 = Shaft with key	Clamping hub bore hole diameter See technical data sheets	Backlash 1 = Standard	

Gearhead type HDP* 010 HDP* 025 HDP* 050	Type code S = Smoothed surface	Gearhead variations M = Motor attachment gearhead	Gearhead model A = HIGH TORQUE	Number of stages 2 = 2-stage
Ratios See technical data sheets	Output shape 0 = Output shaft	Clamping hub bore hole diameter See technical data sheets	Backlash 1 = Standard (≤ 1 arcmin)	

Actuator type AXV 060 AXV 080 AXV 115	Version G = Grease filling H = Food-grade grease X = Special model	Ratio 3 characters: 016 to 100	Return System R = Resolver, 2-pole I = Incremental encoder, optical S = EnDat absolute encoder, single turn M = EnDat absolute encoder, multi-turn N = Hiperface absolute encoder, single-turn K = Hiperface absolute encoder, multi-turn T = Incremental encoder with hall signal	Operating voltage 6 = 560 V
Temperature sensor P = PTC K = KTY	Break B = With break O = Without break	Backlash 1 = Standard		Motor size 53 mm 64 mm 94 mm
Stator length A = 15 mm B = 30 mm C = 45 mm	Electr. connection K = Cable gland	Pin/cable assignment 1 = Temperature sensor in signal cable 4 = Temperature sensor in power cable		Special model 3 characters, consecutive

Order codes HDV 015/025/035

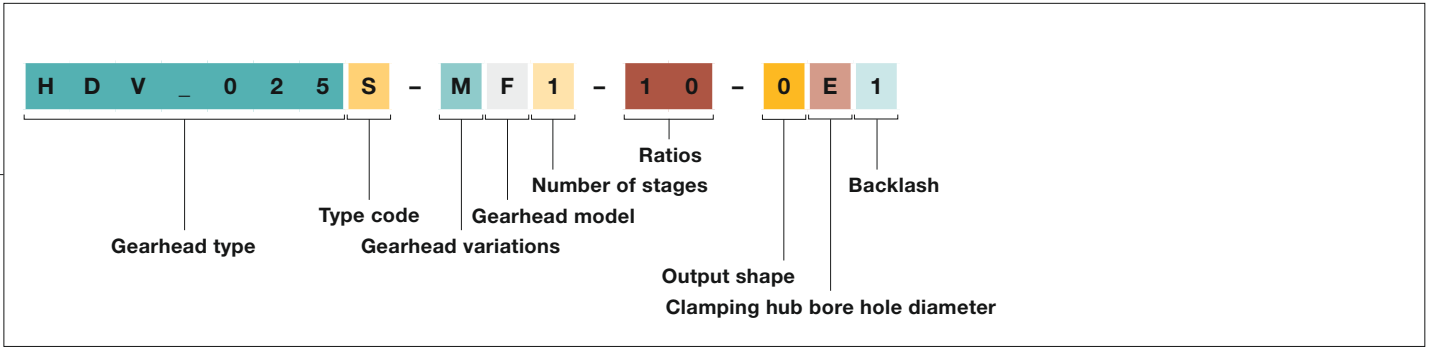

Order codes HDP+ 010/025/050

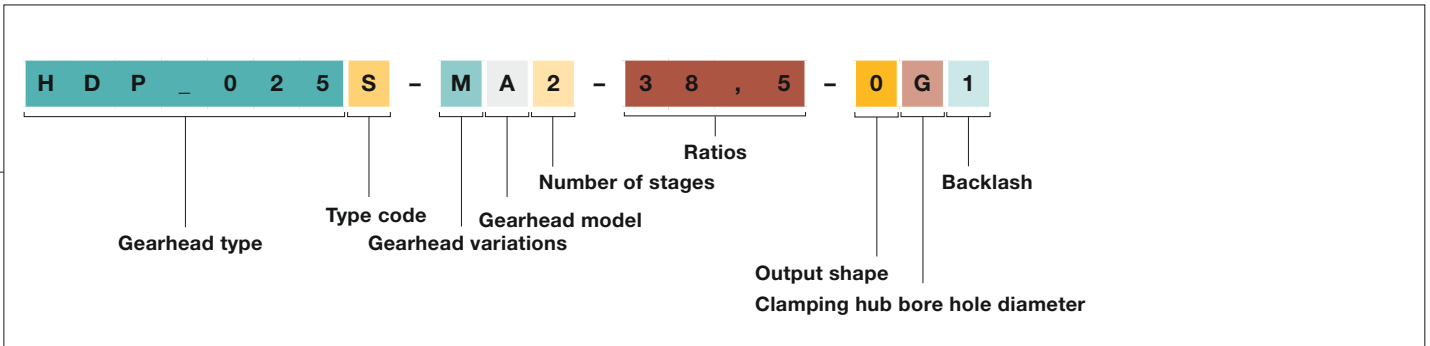

Mounting positions HDP+

B5 – Horizontal

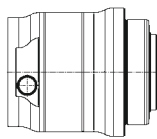

V1 – Vertical output shaft upwards

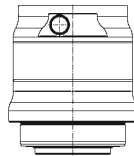

V3 – Vertical output shaft upwards

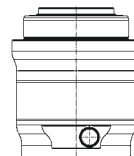

S – Can be tilted $\pm 90^\circ$ from a horizontal position

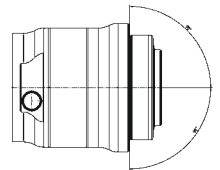

Order codes AXV 060/080/115

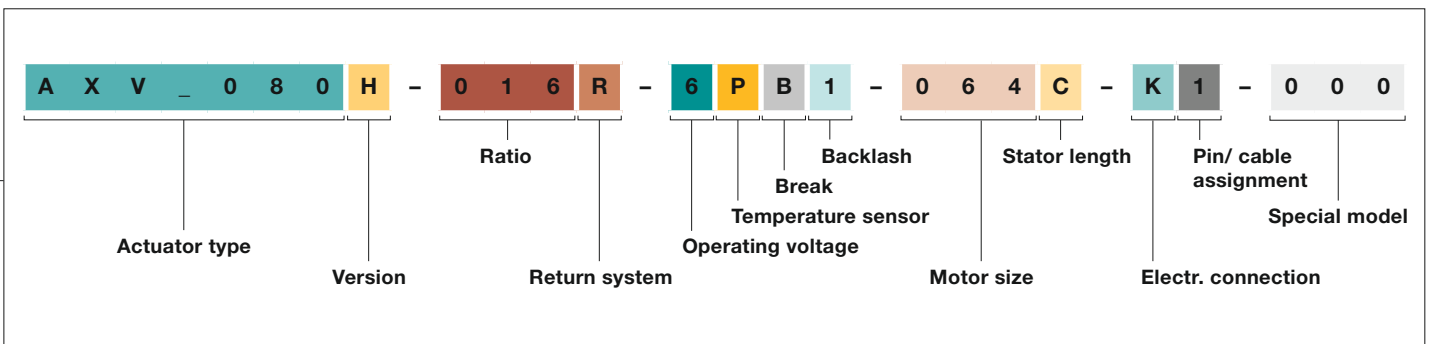



WITTENSTEIN alpha · 1249 Humbracht Circle · Bartlett, IL 60103, USA · Tel. +1 630 540-5300 · info@wittenstein-us.com

WITTENSTEIN alpha – intelligent drive systems

www.wittenstein-alpha.com

